

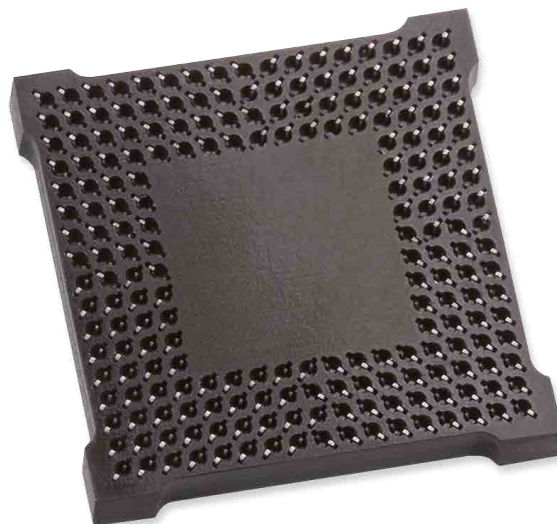

# Grypper G80

104468-0006 Contact  
0.8 Pitch / 0.5 Ball Diameter  
1.0 Pitch / 0.5 Ball Diameter



## TEST OBJECTIVE

The objective of this report is to determine the RF transmission characteristics of the Ironwood Electronics Grypper G80 contact socket for the GSG (ground-signal-ground) configurations. Two product variations, Pattern 2A and Pattern 8A, at pitches of 0.8 mm and 1.0 mm were studied. Three-dimensional electromagnetic (EM) field models were simulated for sockets with three contacts embedded in the dielectric material at a pitch of 0.8 mm and 1.0 mm and using a ball diameter of 0.5 mm. Real measurements were performed on the 0.8 mm product, and correlated to the simulated P2A 3D model. Three-dimensional EM field models were also simulated for sockets with nine contacts, one signal contact surrounded by eight ground contacts, at the 0.8 mm and 1.0 mm pitch. Schematic level circuit models were then derived from these simulations and measurements. Data derived from the 3D simulations, physical measurements and schematic models determine the electrical specifications for the Grypper G80 socket.

P2A Configuration	P8A Configuration	Pitches (mm), 0.5 mm Ball	Contact Part Number
 Pattern 2A	 Pattern 8A	0.8 1.0	104468-0006 104468-0006

## ELECTRICAL SPECIFICATIONS

P2A Configuration	0.8 mm Pitch*	1.0 mm Pitch	Value Determination
Time Delay	15.0 pS	16.0 pS	Inverse Fast Fourier transform on the transmission, S21, S-parameter.
Short Circuit Inductance	0.90 nH	1.19 nH	Values are determined by a short-circuit one-port model at 1 GHz.
Open Circuit Capacitance	0.224 pF	0.195 pF	Values are determined by an open-circuit one-port model at 1 GHz.
S21 Insertion Loss	-1 dB @ 22 GHz	-1 dB @ 31 GHz	Values are based on the 3D model results, except where verified by measurements.
S11 Return Loss	-10 dB @ 39 GHz -20 dB @ 6.5 GHz	-10 dB @ 7.5 GHz -20 dB @ 2.0 GHz	
Impedance	63.4 $\Omega$	78 $\Omega$	Value calculated from Short Circuit Inductance and Open Circuit Capacitance.
Crosstalk, S41, GSSG Thru	-20 dB @ 5.0 GHz	-20 dB @ 3.2 GHz	Values are based on the 3D model results.

\*Specification based on lab measurements.

P8A Configuration	0.8 mm Pitch	1.0 mm Pitch	Value Determination
Time Delay	13.9 pS	14.3 pS	Inverse Fast Fourier transform on the transmission, S21, S-parameter.
Short Circuit Inductance	0.75 nH	0.88 nH	Values are determined by a short-circuit one-port model at 1 GHz.
Open Circuit Capacitance	0.30 pF	0.26 pF	Values are determined by an open-circuit one-port model at 1 GHz.
S21 Insertion Loss	-1 dB > 40 GHz	-1 dB > 40 GHz	Values are based on the 3D model results, except where verified by measurements.
S11 Return Loss	-10 dB > 40 GHz -20 dB @ 18 GHz	-10 dB @ 35 GHz -20 dB @ 6.0 GHz	
Impedance	50 Ω	58 Ω	Value calculated from Short Circuit Inductance and Open Circuit Capacitance.

RESULTS FOR PATTERN 2A

3D Model Simulations for Pattern 2A

Three dimensional EM field simulations were performed using Ansoft's High Frequency Structure Simulator (HFSS™) software. Measurement ports are located at the contact points on the top, Port 1, and bottom, Port 2, of the socket. This model was updated to reflect the UV cured silicone based adhesive shown in light gray.

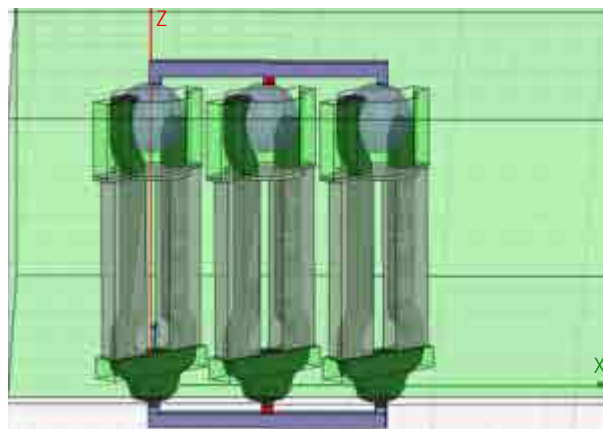

Figure 1. 0.8 mm GSG model configuration

Figure 2 and Figure 3 show results for the GSG 2-port configuration at both 0.8 mm and 1.0 mm pitch.

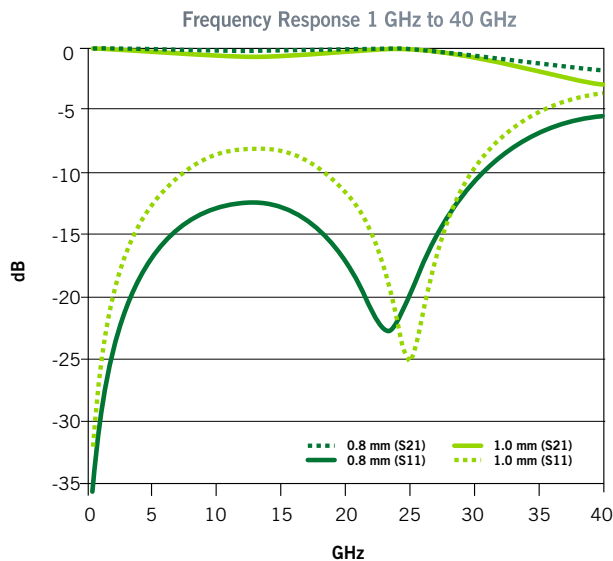

Figure 2. GSG P2A Insertion Loss and Return Loss

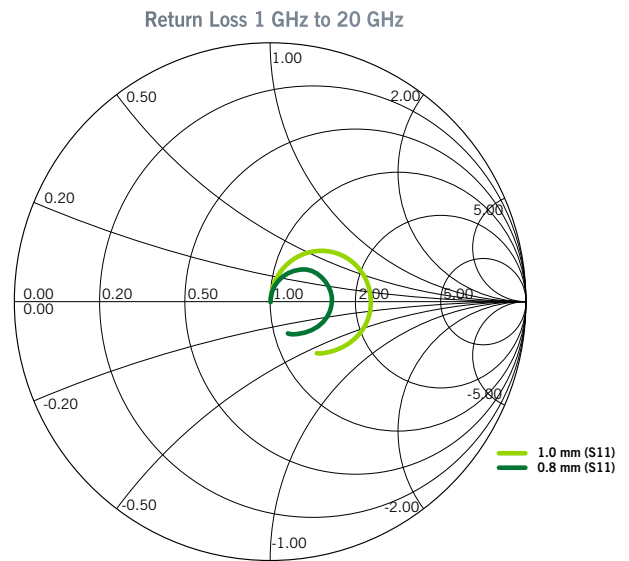

Figure 3. GSG P2A Return Loss plotted on Smith chart

**Measurements for Pattern 2A**

Cascade Microtech’s FPC-800 GSG probes were used to obtain the 0.8 mm socket measurements. To provide a first-order approximation of the socket’s performance, the socket was mounted on a small brass plate containing an opening allowing access to the contact area. The plate and socket assembly was then mounted on a positioner and simultaneously probed from both the top and bottom sides. The measured insertion loss is approximately -0.8 dB at 20 GHz, slightly more loss than the HFSS™ model’s expected value.

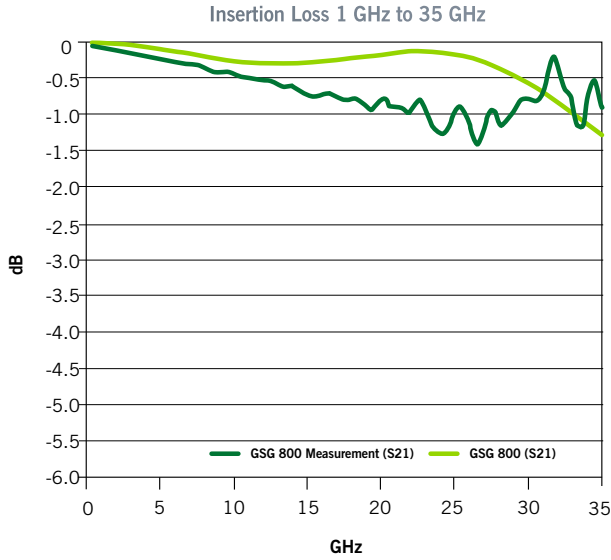

Figure 4. GSG P2A Insertion Loss comparison, 0.8 mm pitch



Figure 5. GSG P2A Return Loss comparison, 0.8 mm pitch

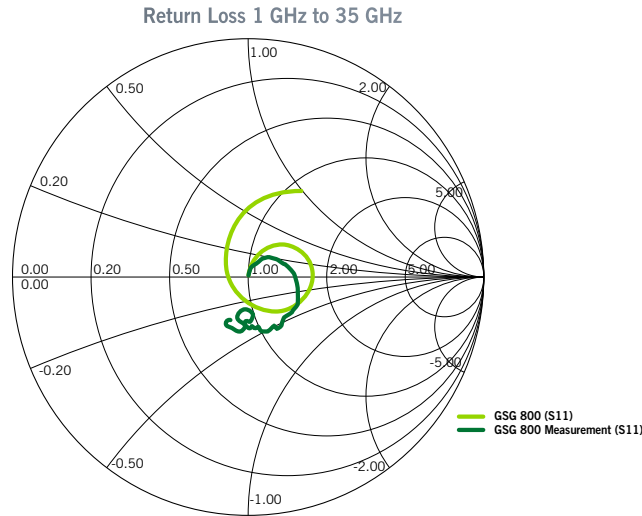

Figure 6. GSG P2A Return Loss comparison plotted on Smith chart, 0.8 mm pitch

**Schematic Model for Pattern 2A Configuration**

Agilent’s Advanced Design System (ADS) was used to construct a GSG schematic model matching the 0.8 mm pitch socket measurement results. The topology selected matches that of the three contacts used in the measurement. The GSG schematic model consists of ten passive components. The signal contact is represented along the top by series inductors totaling 629 pH series inductor. The two ground return paths are joined together in parallel and represented along the bottom series inductors, totaling 314 pH. Shunt capacitors bridge the signal contact and the ground return path. Total capacitance is 223 fF. Finally, an added mutual inductance 78 pH represents the mutual coupling between the two ground contacts and signal.

RESULTS FOR PATTERN 2A CONT...

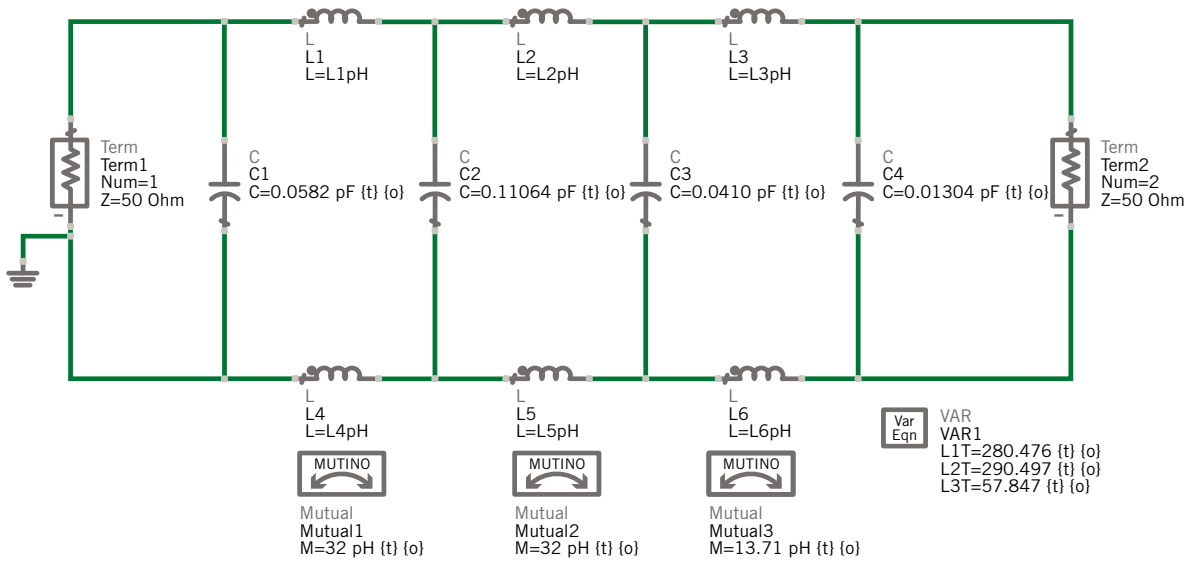

Figure 7. GSG P2A Schematic Model, 0.8 mm pitch

An additional pair of ports (ports 3 and 4 not shown) were added in the simulation to compare the schematic model to the GSG measurement file.

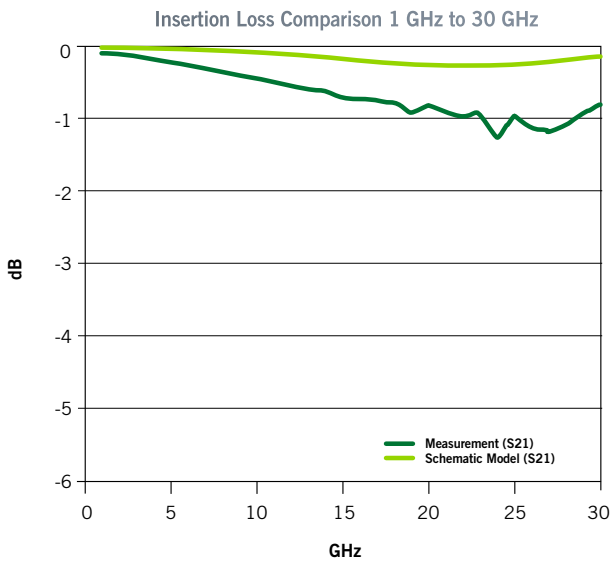

Figure 8. GSG P2A Insertion Loss, 0.8 pitch



Figure 9. GSG P2A Return Loss, 0.8 pitch

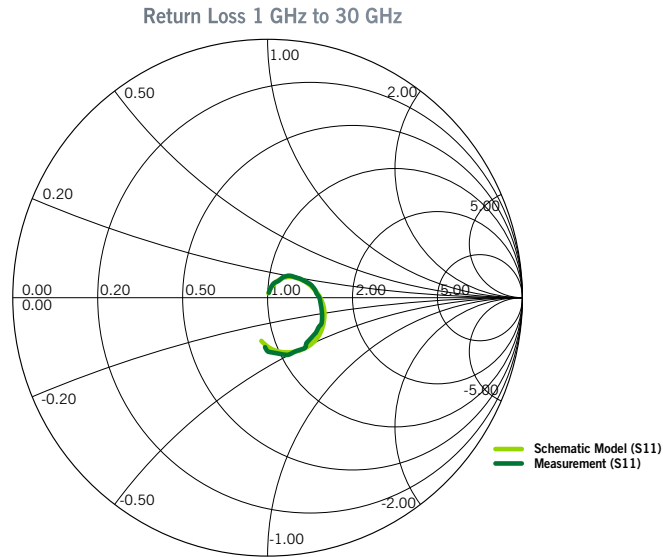

Figure 10. GSG P2A Return Loss plotted on Smith chart, 0.8 pitch

RESULTS FOR PATTERN 8A

3D Model Simulations for Pattern 8A

Three dimensional EM field simulations were performed using Ansoft's High Frequency Structure Simulator (HFSS™) software. Measurement ports are located at the contact points on the top, Port 1, and bottom, Port 2, of the socket. This model was updated to reflect the UV cured silicone based adhesive shown in light gray.

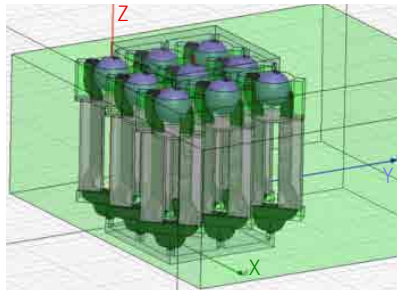

Figure 11. 0.8 mm GSG P8A model configuration

Figure 12 and Figure 13 show results for the GSG P8A 2-port configuration at both 0.8 mm and 1.0 mm pitch.

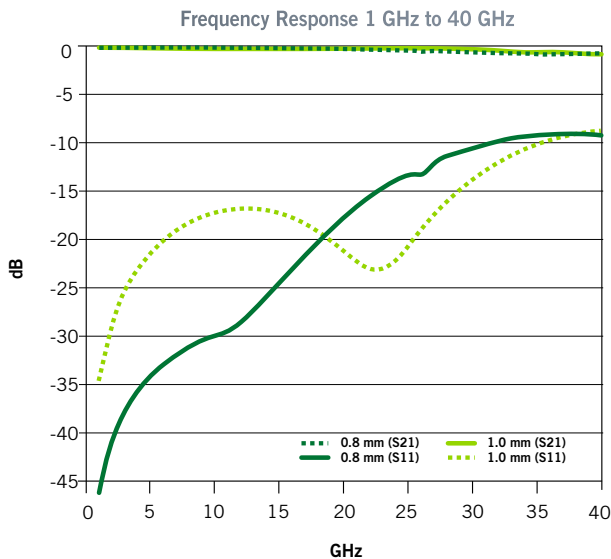

Figure 12. GSG P8A Insertion Loss and Return Loss

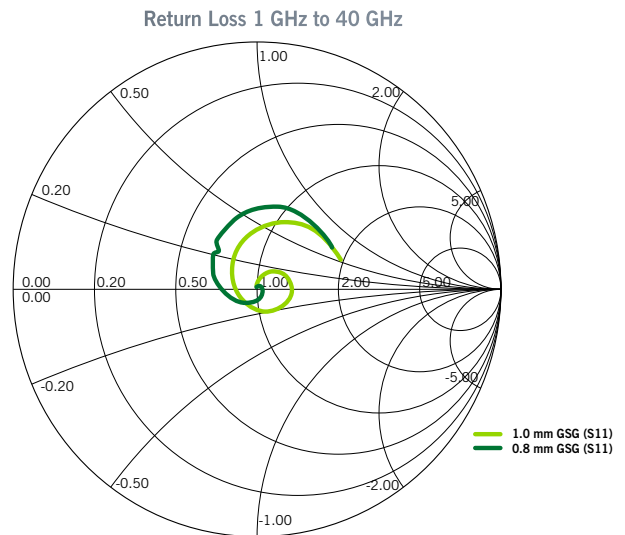

Figure 13. GSG P8A Return Loss plotted on Smith chart

## RESULTS FOR PATTERN 8A CONT...

### Measurements for Pattern 8A

P8A measurements are not available at this time.

### Schematic Model for Pattern 8A Configuration

Agilent's Advanced Design System (ADS) was used to construct a GSG schematic model matching the 0.8 mm pitch socket simulation results. The topology selected matches that of the one signal contact surrounded by eight ground contacts used in the simulation. The GSG schematic model consists of ten passive components. The signal contact is represented along the top by series inductors totaling 577 pH series inductor. The eight return paths are joined together in parallel and represented along the bottom series inductors, totaling 72 pH. Shunt capacitors bridge the signal contact and the ground return path. Total capacitance is 236 fF. Finally, an added mutual inductance 70 pH represents the mutual coupling between the two ground contacts and signal.

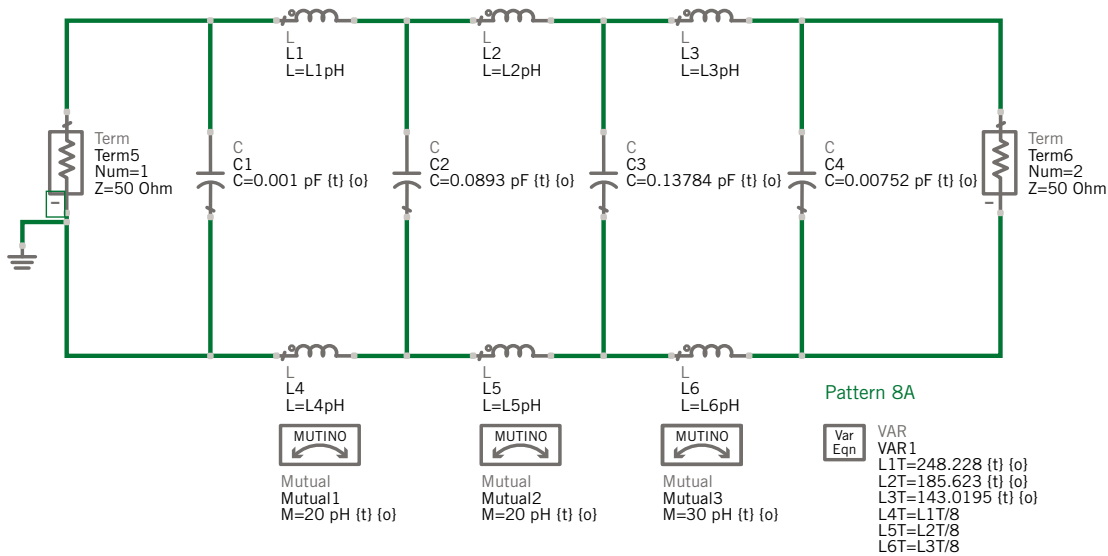

Figure 14. GSG P8A Schematic Model, 0.8 mm pitch

An additional pair of ports (ports 3 and 4, not shown) were added in the simulation to compare the schematic model to the GSG simulation file.

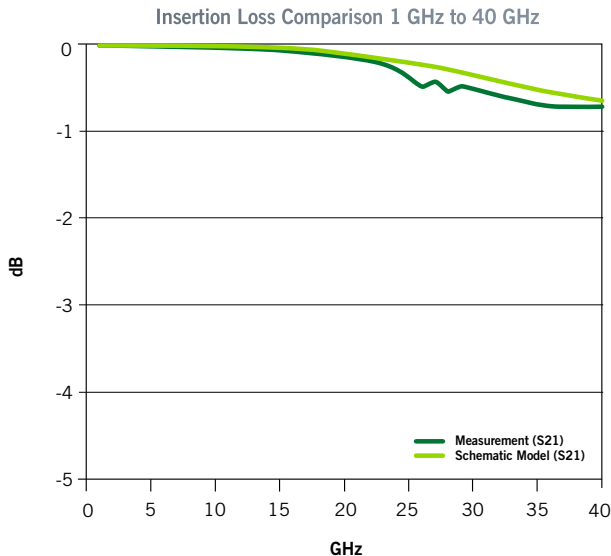

Figure 15. GSG P8A Insertion Loss, 0.8 pitch



Figure 16. GSG P8A Return Loss, 0.8 pitch

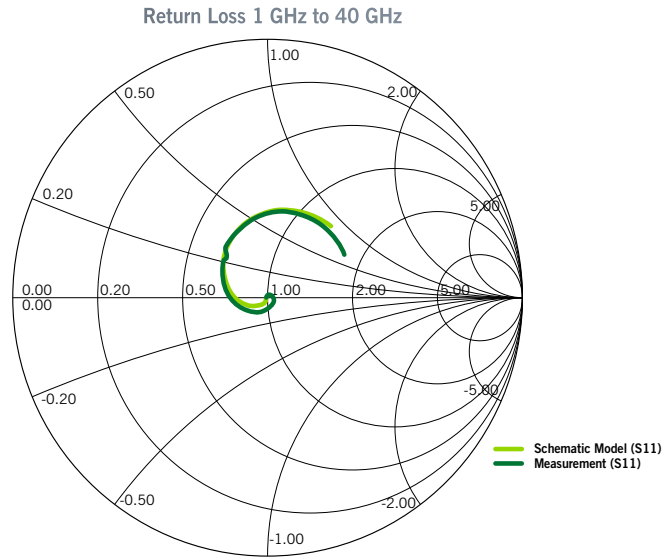
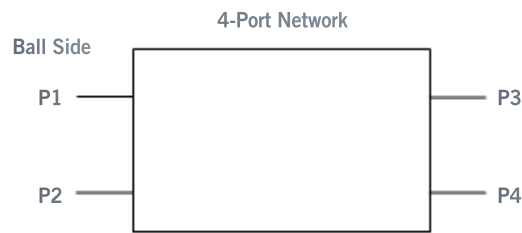

Figure 17. GSG P8A Return Loss Simulation plotted on Smith chart, 0.8 mm pitch

GSSG CROSSTALK ANALYSIS

A 4-Port S-parameter analysis was done to determine the Near End (S21) and Far End (S41) crosstalk.



Far End and Near End Crosstalk for GSSG at 0.8 mm Pitch

The model was analyzed in HFSS™.

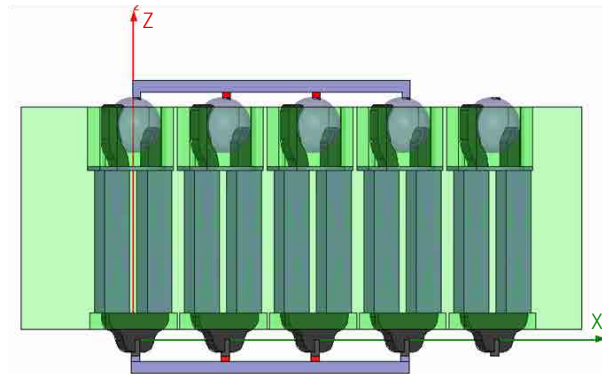

Figure 18. 0.8 mm GSSG model configuration

**Far End and Near End Crosstalk for GSSG at a 1.0 mm Pitch**

The model was analyzed in HFSS™.

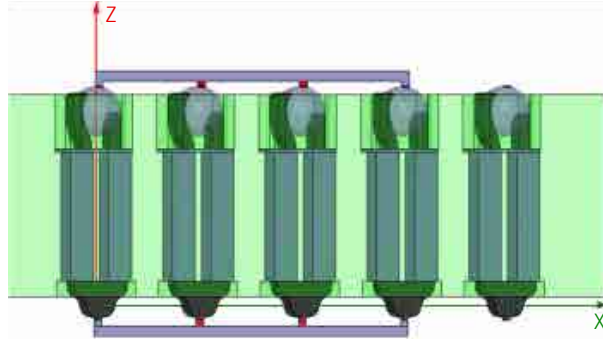

Figure 19. 1.0 mm GSSG model configuration

The Figure 20 plot shows the results for the Grypper G80 with the 0.8 mm pitch. The -20 dB Far End crosstalk limit (10% voltage crosstalk) is reached at 5.0 GHz. The Figure 21 plot shows the results for the Grypper G80 with the 1.0 mm pitch. The -20 dB Far End crosstalk limit (10% voltage crosstalk) is reached at 3.2 GHz.

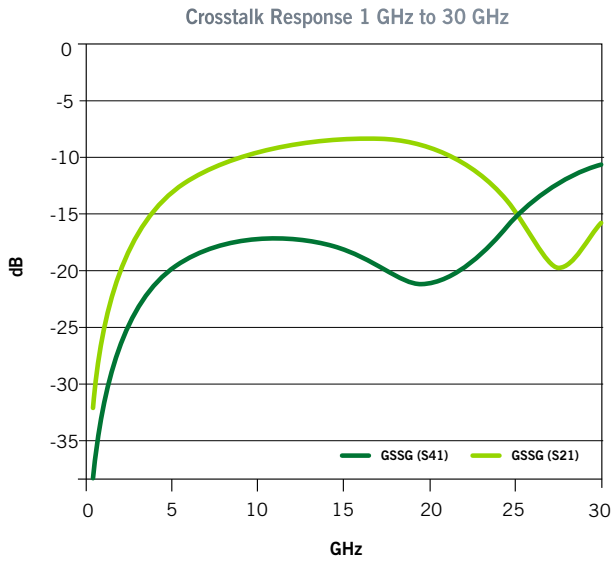

Figure 20. GSSG Crosstalk Response, 0.8 mm pitch

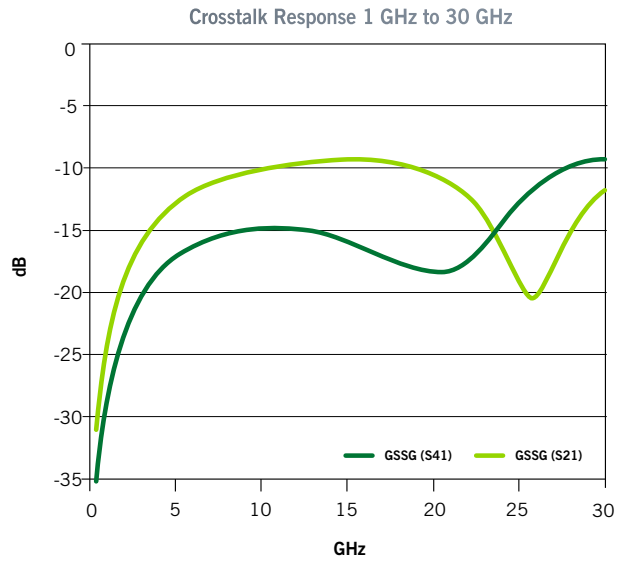

Figure 21. GSSG Crosstalk Response, 1.0 mm pitch



**B.C.E. s.r.l.**  
 Via Regina Pacis, 54/c - 41049 SASSUOLO (MO) Italy  
 Tel. +39 0536 811.616 r.a. - Fax +39 0536 811.500  
 www.bce.it - E-mail: bce@bce.it

