



actual size

SMD Quartz Crystal · JXG32P4

- 4 pad version, 3.2 x 2.5 mm
- glass sealed ceramic package
- extended temperature ranges available
- high mechanical reliability type available
- for automotive type, see automotive datasheet



RoHS compliant



Pb free



REACH compliant



Conflict mineral free

GENERAL DATA	
TYPE	JXG32P4
frequency range	12.0 ~ 50.0 MHz (fund. AT-cut)
frequency tolerance at 25 °C	±30 ppm, ±50 ppm
load capacitance C_L	12 pF standard (option: 10 pF ~ 30 pF / series)
shunt capacitance C_0	< 7 pF max.
storage temperature	-40 °C ~ +125 °C
drive level max.	100 µW (10 µW recommended)
aging	< ±3 ppm first year

ESR (SERIES RESISTANCE R_S)			
frequency in MHz	vibration mode	ESR max. in Ω	ESR typ. in Ω
12.0 ~ 12.999	fund. - AT	200	90
13.0 ~ 13.999	fund. - AT	150	70
14.0 ~ 15.999	fund. - AT	100	40
16.0 ~ 18.999	fund. - AT	80	35
19.0 ~ 21.999	fund. - AT	70	30
22.0 ~ 29.999	fund. - AT	70	25
30.0 ~ 50.000	fund. - AT	50	20

TABLE 1: FREQUENCY STABILITY VS. TEMPERATURE				
		± 30 ppm	±50 ppm	±100 ppm
-20 °C ~ +70 °C	STD.	●	○	○
-40 °C ~ +85 °C	T1	○	●	○
-40 °C ~ +105 °C	T2		○	○
-40 °C ~ +125 °C	T3			○

● standard ○ available

MARKING						
frequency with load capacitance code						
company code / date code / internal code						
date code: A ~ M: Jan. - Dec.						
7: 2017	8: 2018	9: 2019	0: 2020	1: 2021	2: 2022	
Jan.	Febr.	Mar.	Apr.	May	June	
A	B	C	D	E	F	
July	Aug.	Sept.	Oct.	Nov.	Dec.	
G	H	J	K	L	M	

DIMENSIONS					
top view	side view	bottom view	crystal connection	pad layout	in mm

ORDER INFORMATION						
Q	frequency	type	load capacitance	tolerance at 25 °C	stability vs. temp. range	option
Quartz	12.0 ~ 50.0 MHz	JXG32P4	12 pF standard 10 pF ~ 30 pF S for series	30 = ±30 ppm 50 = ±50 ppm	30 = ±30 ppm 50 = ±50 ppm 100 = ±100 ppm	blank = -20 °C ~ +70 °C T1 = -40 °C ~ +85 °C T2 = -40 °C ~ +105 °C T3 = -40 °C ~ +125 °C FU = for fundamental frequencies ≥ 20 MHz HMR = high mechanical reliability (3000g/half sine wave/0.3 ms)

Example: Q 28.0-JXG32P4-12-30/30-FU-LF (Suffix LF = RoHS compliant / Pb free pins or pads)



B.C.E. S.r.l. - Via Regina Pacis, 54/c - Sassuolo (MO) - I 41049 - Italy
 Tel.: 0536 811616 - Fax: 0536 811500 - Web: www.bce.it - E-mail: bce@bce.it

01042019

Jauch Quartz GmbH • e-mail: info@jauch.com • full data can be found under: www.jauch.com
 All specifications are subject to change without notice

SMD Quartz Crystal · JXG32P4

TAPING SPECIFICATION

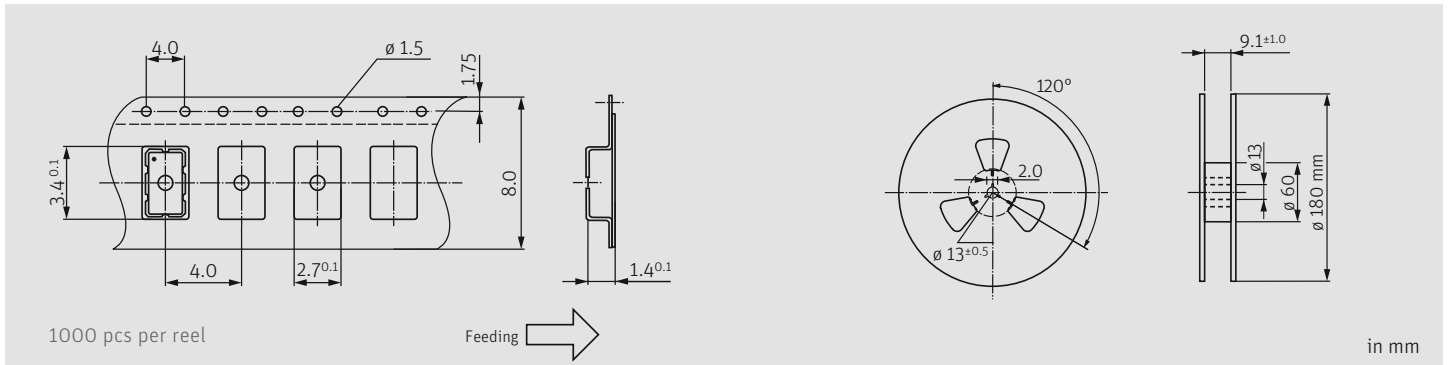

REFLOW SOLDERING PROFILE

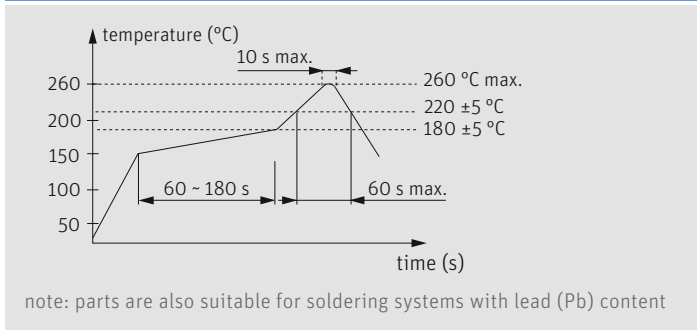

LOAD CAPACITANCE CODES

8 pF: k	14 pF: x	22 pF: g	series: s
9 pF: n	15 pF: j	24 pF: d	T: 3rd OT
10 pF: h	16 pF: b	25 pF: r	
11 pF: l	17 pF: t	27 pF: w	
12 pF: a	18 pF: f	30 pF: .	
13 pF: v	20 pF: c		

example 20.0 MHz / 12 pF: 20a00