

FREQUENCY CONTROL PRODUCTS

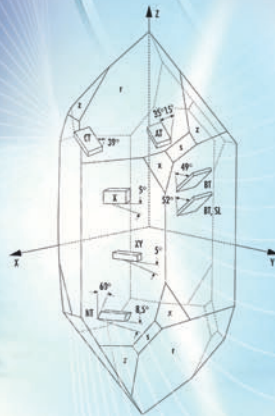

JAUCH QUARTZ CRYSTALS

individual working copy

03/11/14

THE SPECIALIST FOR FREQUENCY CONTROL PRODUCTS



The Specialist
for frequency control products

Worldwide Presence
expert advice by
quartz crystal specialists

Technical Customer Support
by field application engineers

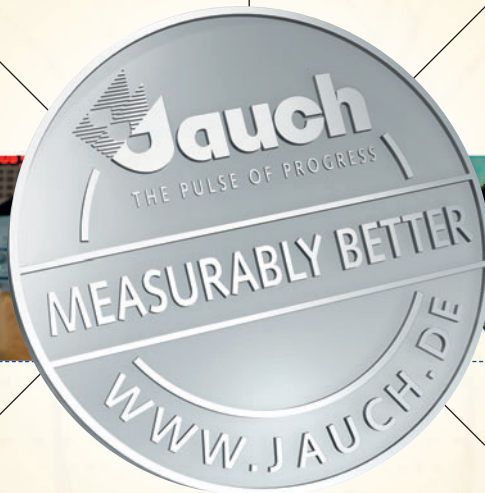

Standard and Customized
quartz crystal products

High Product Availability
with over 28 million
components in stock

Flexibility and Reliability
by our own international
production facilities



Quartz Crystals

SMD - JXG Series	Type	Frequency range	Size	PDF	Information
JXG12P4	4 Pad Version	13.0 - 50.0 MHz	3.2 x 2.5 x 1.0 mm		<ul style="list-style-type: none"> automotive temperature range available high mechanical reliability type available glass sealing contains small amount of Pb in accordance with RoHS directive exemption No 7
JXG63P4	4 Pad Version	8.0 - 60.0 MHz	5.0 x 3.2 x 1.5 mm		<ul style="list-style-type: none"> automotive temperature range available high mechanical reliability type available glass sealing contains small amount of Pb in accordance with RoHS directive exemption No 7
JXG53P2	2 Pad Version preferred type	8.0 - 60.0 MHz	5.0 x 3.2 x 1.5 mm		<ul style="list-style-type: none"> automotive temperature range available
JXG75P4	4 Pad Version	5.0 - 70.0 MHz	7.0 x 5.0 x 1.8 mm		
JXG75P2	2 Pad Version preferred type	5.0 - 70.0 MHz	7.0 x 5.0 x 1.8 mm		
JXG4AP2	2 Pad Version	6.0 - 60.0 MHz	8.0 x 4.5 x 1.4 mm		

Jauch
The pulse of progress

Alle Spezialisten für Frequenzgehende Bauelemente stellen wir Produkte bereit, die zwar nicht spektakulär sein mögen, aber unser gesamtes Leben prägen. Die Welt von Jauch: Hier treffen Menschen und Ideen von überall her zusammen – in jenem Rhythmus, den unsere industrielle, technisch geprägte Welt fordert: kraftvoll, dynamisch und innovativ.

Die Welt von Jauch Quartz: Lernen Sie sie kennen! Sie sind uns willkommen!

THE SPECIALIST FOR FREQUENCY CONTROL PRODUCTS

www.jauch.de
www.jauch.fr
www.jauchusa.com
www.jauch.co.uk

Index

JXG32P4 4 Pad Version	6
JXG53P4 4 Pad Version	8
JXG53P2 2 Pad Version preferred type	10
JXG75P4 4 Pad Version	12
JXG75P2 2 Pad Version preferred type	14
JXS11	16
JXS21	18
JXS22	20
JXS32	22
JXS53	24
JXS63	26
JXS75	28
SMU2 2 Pad Version	30
SMU3 2 Pad Version	32
SMU4 2 Pad Version	34
SMU5 4 Pad Version	36
MG3A 4 Pad Version	38
SS2	40
SS3	42
SS4	44
HC49/U	46
HC49/U SMC SMD Version	48
MQ1 (UM-1)	50
MQ1 SMC SMD Version	52
MQ5 (UM-5)	54
MQ5 SMC SMD Version	56
MTF38	58
JTX210	60
JTX310	62
JTX410	64



Index

JTX520	66
SMQ32SN	68
SMQ32SL	70
SMQ32S	72
SMQ32	74
SM26F	76
MMTF32	78
MTF32	80
JXS42	82







actual size

SMD Quartz Crystal · JXG32P4

4 Pad Version · 3.2 x 2.5 mm

- glass sealed ceramic package
- extended temperature ranges available
- high mechanical reliability type available
- for automotive type, see automotive datasheet



General Data

type	JXG32P4	
frequency range	12.0 ~ 50.0 MHz	(fund. AT-cut)
frequency stability at 25 °C	± 30 ppm, ± 50 ppm	
load capacitance C_L	12 pF standard	(option: 10 pF ~ 30 pF / series)
shunt capacitance C_0	< 7 pF max.	
storage temperature	-40 °C ~ +125 °C	
drive level max.	100 µW (10 µW recommended)	
aging	< ± 3 ppm first year	

ESR (series resistance R_s)

frequency in MHz	vibration mode	ESR max. in Ω	ESR typ. in Ω
12.0 ~ 12.999	fund.-AT	200	90
13.0 ~ 13.999	fund.-AT	150	70
14.0 ~ 15.999	fund.-AT	100	40
16.0 ~ 18.999	fund.-AT	80	35
19.0 ~ 21.999	fund.-AT	70	30
22.0 ~ 29.999	fund.-AT	70	25
30.0 ~ 50.000	fund.-AT	50	20

Frequency Stability vs. Temperature

		± 30 ppm	± 50 ppm	± 100 ppm		
-20 °C ~ +70 °C	STD.	●	○	○		
-40 °C ~ +85 °C	T1	○	●	○		
-40 °C ~ +105 °C	T2		○	○		
-40 °C ~ +125 °C	T3			○		

● standard
○ available

Marking

frequency with load capacitance code
company code / date code / internal code

date code: year/month
example: 2A = 2012 January

Jan.	Febr.	Mar.	Apr.	May	June
A	B	C	D	E	F

July	Aug.	Sept.	Oct.	Nov.	Dec.
G	H	J	K	L	M

Dimensions

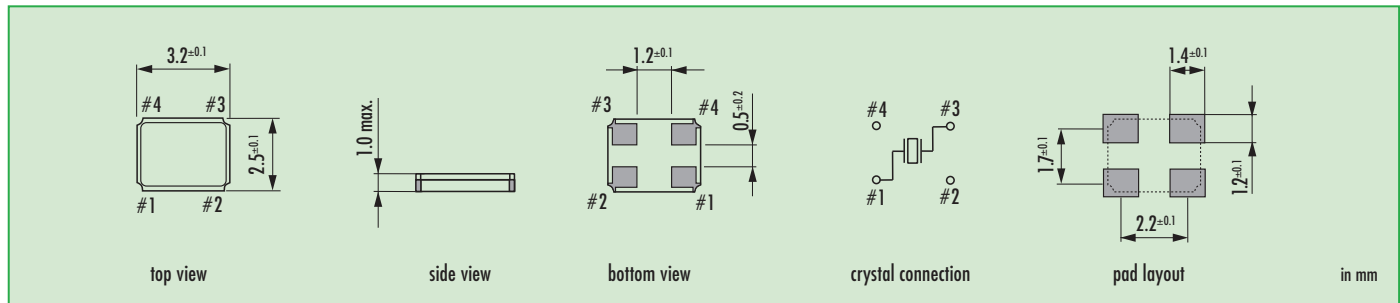

Order Information

Q	frequency	type	load capacitance	stability at 25 °C	stability vs. temp. range	option
Quartz	12.0 ~ 50.0 MHz	JXG32P4	12 pF standard 10 pF ~ 30 pF S for series	30 = ± 30 ppm 50 = ± 50 ppm	30 = ± 30 ppm 50 = ± 50 ppm 100 = ± 100 ppm	blank = -20 °C ~ +70 °C T1 = -40 °C ~ +85 °C T2 = -40 °C ~ +105 °C T3 = -40 °C ~ +125 °C FU = for fundamental frequencies ≥ 20 MHz HMR = high mechanical reliability (3000g/half sine wave/0.3ms)

Example: Q 28.0-JXG32P4-12-30/30-FU-LF (Suffix LF = RoHS compliant / Pb free pads)



SMD Quartz Crystal · JXG32P4

Taping Specification

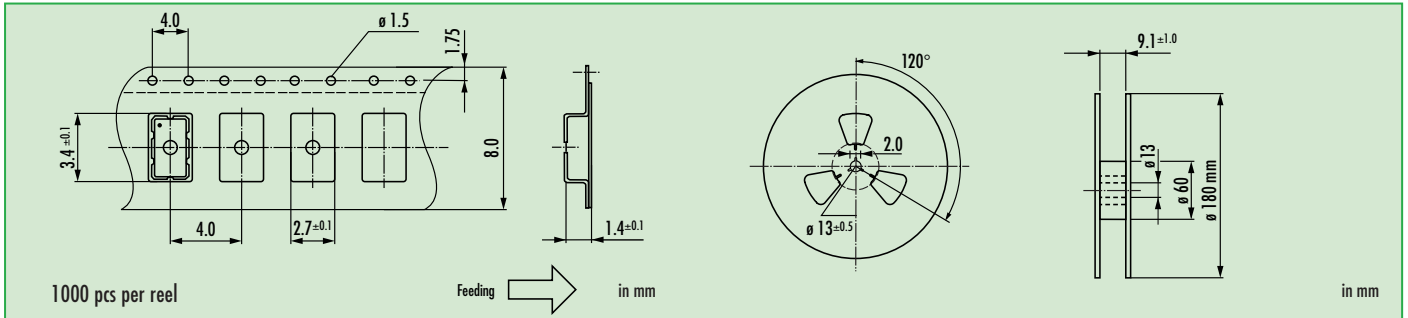

Reflow Soldering Profile

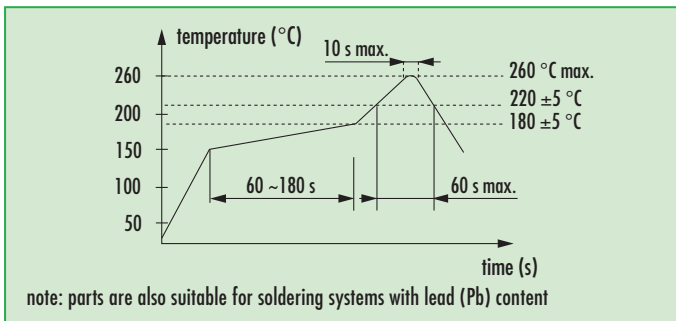

Load Capacitance Codes

8 pF: k	14 pF: x	22 pF: g	series: s
9 pF: n	15 pF: j	24 pF: d	T: 3rd OT
10 pF: h	16 pF: b	25 pF: r	
11 pF: l	17 pF: t	27 pF: w	
12 pF: a	18 pF: f	30 pF: .	
13 pF: v	20 pF: c		

example 20.0 MHz / 12 pF: 20a00





actual size

SMD Quartz Crystal · JXG53P4

4 Pad Version · 5.0 x 3.2 mm

- glass sealed ceramic package
- extended temperature ranges available
- high mechanical reliability type available
- for automotive type, see automotive datasheet



General Data

type	JXG53P4	
frequency range	8.0 ~ 50.0 MHz	(fund. AT-cut)
	45.0 ~ 60.0 MHz	(3rd OT AT-cut)
frequency stability at 25 °C	± 30 ppm, ± 50 ppm	
load capacitance C_L	12 pF standard	(option: 10 pF ~ 30 pF / series)
shunt capacitance C_0	< 7 pF max.	
storage temperature	-40 °C ~ +125 °C	
drive level max.	100 µW (10 µW recommended)	
aging	< ± 3 ppm first year	

ESR (series resistance R_s)

frequency in MHz	vibration mode	ESR max. in Ω	ESR typ. in Ω
8.0 ~ 8.999	fund.-AT	300	200
9.0 ~ 9.999	fund.-AT	250	180
10.0 ~ 11.999	fund.-AT	60	35
12.0 ~ 15.999	fund.-AT	60	25
16.0 ~ 21.999	fund.-AT	50	20
22.0 ~ 24.999	fund.-AT	40	15
25.0 ~ 50.000	fund.-AT	30	15
45.0 ~ 60.000	3rd OT-AT	90	65

Frequency Stability vs. Temperature

		± 30 ppm	± 50 ppm	± 100 ppm		
-20 °C ~ +70 °C	STD.	●	○	○		
-40 °C ~ +85 °C	T1	○	●	○		
-40 °C ~ +105 °C	T2		○	○		
-40 °C ~ +125 °C	T3			○		

● standard
○ available

Marking

frequency with load capacitance code
company code / date code / internal code

date code: year/month
example: 2A = 2012 January

Jan.	Feb.	Mar.	Apr.	May	June
A	B	C	D	E	F

July	Aug.	Sept.	Oct.	Nov.	Dec.
G	H	J	K	L	M

Dimensions

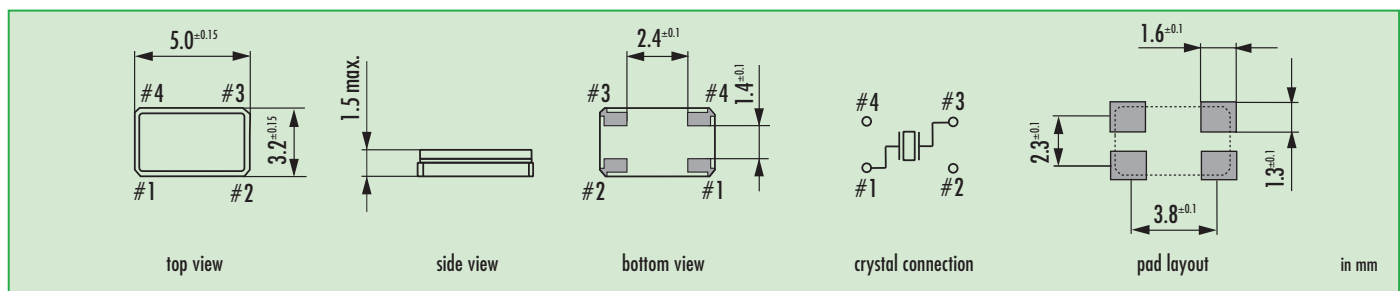

Order Information

Q	frequency	type	load capacitance	stability at 25 °C	stability vs. temp. range	option
Quartz	8.0 ~ 60.0 MHz	JXG53P4	12 pF standard 10 pF ~ 30 pF 5 for series	30 = ± 30 ppm 50 = ± 50 ppm	30 = ± 30 ppm 50 = ± 50 ppm 100 = ± 100 ppm	blank = -20 °C ~ +70 °C T1 = -40 °C ~ +85 °C T2 = -40 °C ~ +105 °C T3 = -40 °C ~ +125 °C FU = for fundamental frequencies ≥ 20 MHz 3OT = 3rd overtone HMR = high mechanical resistance (3000g/half sine wave/0.3ms)

Example: Q 28.0-JXG53P4-12-30/30-FU-LF (Suffix LF = RoHS compliant / Pb free pads)



SMD Quartz Crystal · JXG53P4

Taping Specification

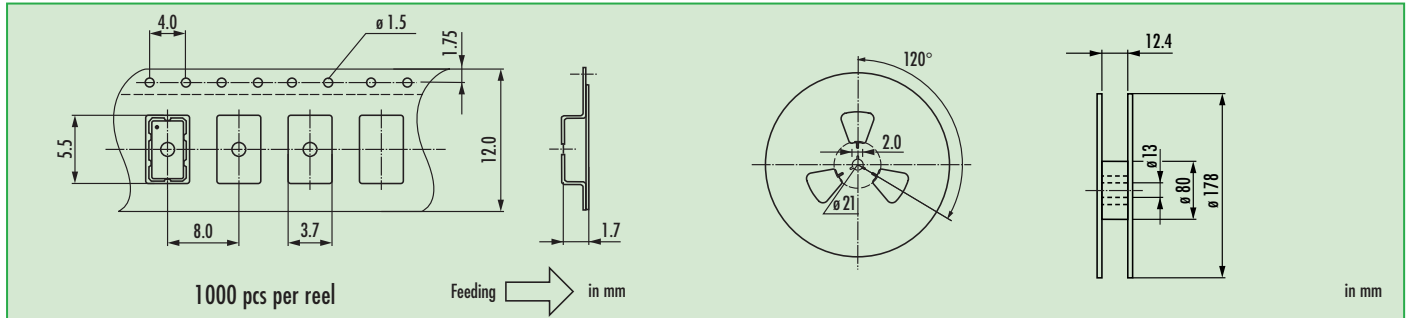

Reflow Soldering Profile

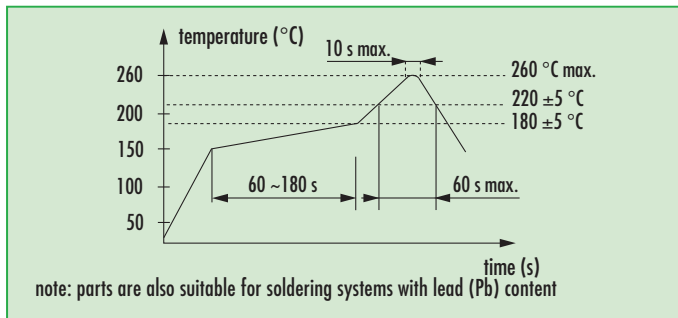

Load Capacitance Codes

8 pF: k	14 pF: x	22 pF: g	series: s
9 pF: n	15 pF: j	24 pF: d	T: 3rd OT
10 pF: h	16 pF: b	25 pF: r	
11 pF: l	17 pF: t	27 pF: w	
12 pF: a	18 pF: f	30 pF: .	
13 pF: v	20 pF: c		

example 12.0 MHz / 12 pF: 12a00





actual size

SMD Quartz Crystal · JXG53P2

2 Pad Version · 5.0 x 3.2 mm

- glass sealed ceramic package
- extended temperature ranges available
- high mechanical reliability type available
- for automotive type, see automotive datasheet



General Data

type	JXG53P2	
frequency range	8.0 ~ 50.0 MHz	(fund. AT-cut)
	45.0 ~ 60.0 MHz	(3rd OT AT-cut)
frequency stability at 25 °C	± 30 ppm, ± 50 ppm	
load capacitance C _L	12 pF standard	(option: 10 pF ~ 30 pF / series)
shunt capacitance C ₀	< 7 pF max.	
storage temperature	-40 °C ~ +125 °C	
drive level max.	100 µW (10 µW recommended)	
aging	< ± 3 ppm first year	

ESR (series resistance R_s)

frequency in MHz	vibration mode	ESR max. in Ω	ESR typ. in Ω
8.0 ~ 8.999	fund.-AT	300	200
9.0 ~ 9.999	fund.-AT	250	180
10.0 ~ 11.999	fund.-AT	60	35
12.0 ~ 15.999	fund.-AT	60	25
16.0 ~ 21.999	fund.-AT	50	20
22.0 ~ 24.999	fund.-AT	40	15
25.0 ~ 50.000	fund.-AT	30	15
45.0 ~ 60.000	3rd OT-AT	90	65

Frequency Stability vs. Temperature

Temperature Range	Grade	± 30 ppm	± 50 ppm	± 100 ppm
-20 °C ~ +70 °C	STD.	●	○	○
-40 °C ~ +85 °C	T1	○	●	○
-40 °C ~ +105 °C	T2		○	○
-40 °C ~ +125 °C	T3			○

● standard
 ○ available

Marking

frequency with load capacitance code
 company code / date code / internal code

date code: year/month
 example: 2A = 2012 January

Jan.	Febr.	Mar.	Apr.	May	June
A	B	C	D	E	F
July	Aug.	Sept.	Oct.	Nov.	Dec.
G	H	J	K	L	M

Dimensions

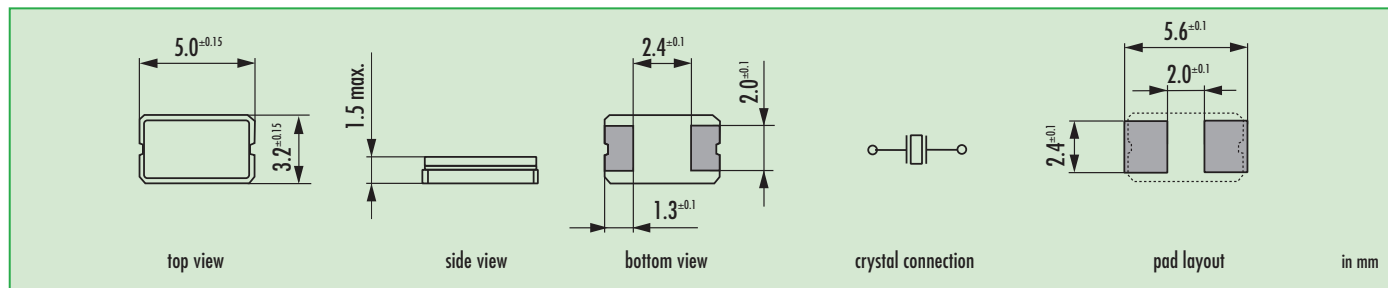

Order Information

Q	frequency	type	load capacitance	stability at 25 °C	stability vs. temp. range	option
Quartz	8.0 ~ 60.0 MHz	JXG53P2	12 pF standard 10 pF ~ 30 pF S for series	30 = ± 30 ppm 50 = ± 50 ppm	30 = ± 30 ppm 50 = ± 50 ppm 100 = ± 100 ppm	blank = -20 °C ~ +70 °C T1 = -40 °C ~ +85 °C T2 = -40 °C ~ +105 °C T3 = -40 °C ~ +125 °C FU = for fundamental frequencies ≥ 20 MHz 30T = 3rd overtone HMR = high mechanical reliability (3000g/half sine wave/0.3ms)

Example: Q 28.0-JXG53P2-12-30/30-FU-LF (Suffix LF = RoHS compliant / Pb free pads)



SMD Quartz Crystal · JXG53P2

Taping Specification

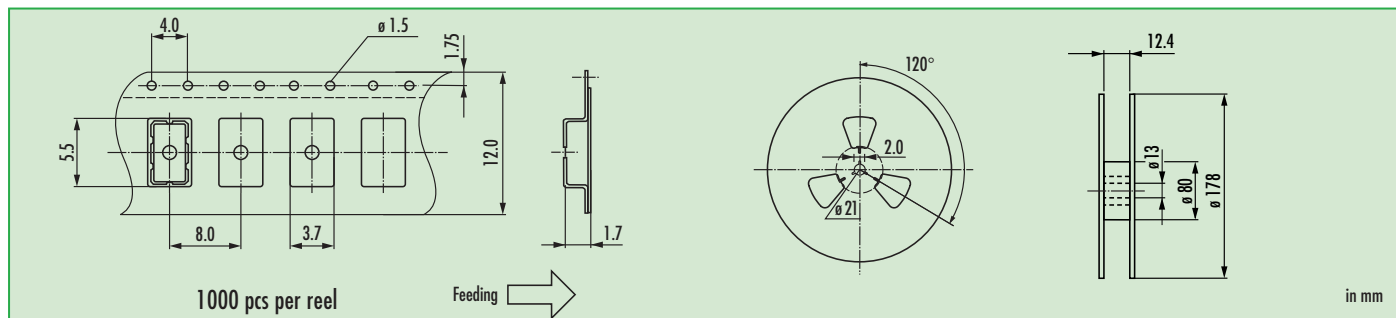

Reflow Soldering Profile

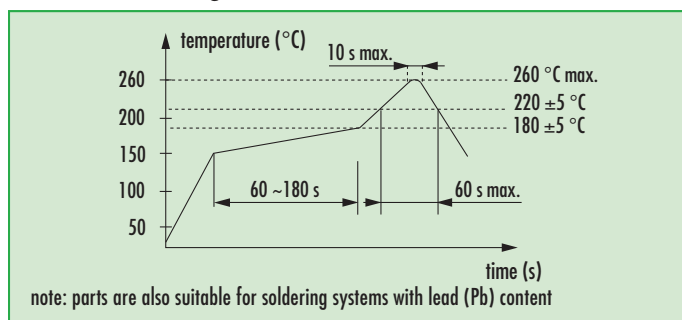

Load Capacitance Codes

8 pF: k	14 pF: x	22 pF: g	series: s
9 pF: n	15 pF: j	24 pF: d	T: 3rd OT
10 pF: h	16 pF: b	25 pF: r	
11 pF: l	17 pF: t	27 pF: w	
12 pF: a	18 pF: f	30 pF: .	
13 pF: v	20 pF: c		

example 12.0 MHz / 12 pF: 12a00





actual size

SMD Quartz Crystal · JXG75P4

4 Pad Version · 7.0 x 5.0 mm

- glass sealed ceramic package
- extended temperature ranges available
- high mechanical reliability type available
- for automotive type, see automotive datasheet



General Data

type	JXG75P4	
frequency range	5.0 ~ 50.0 MHz	(fund. AT-cut)
	30.0 ~ 70.0 MHz	(3rd OT AT-cut)
frequency stability at 25 °C	± 30 ppm, ± 50 ppm	
load capacitance C_L	12 pF standard	(option: 10 pF ~ 30 pF / series)
shunt capacitance C_0	< 7 pF max.	
storage temperature	-40 °C ~ +125 °C	
drive level max.	100 µW (10 µW recommended)	
aging	< ± 3 ppm first year	

ESR (series resistance R_s)

frequency in MHz	vibration mode	ESR max. in Ω	ESR typ. in Ω
5.0 ~ 5.999	fund.-AT	200	120
6.0 ~ 6.999	fund.-AT	100	55
7.0 ~ 9.999	fund.-AT	80	30
10.0 ~ 15.999	fund.-AT	60	20
16.0 ~ 21.999	fund.-AT	50	15
22.0 ~ 39.999	fund.-AT	40	15
40.0 ~ 50.000	fund.-AT	30	11
30.0 ~ 44.999	3rd OT-AT	80	60
45.0 ~ 70.000	3rd OT-AT	70	55

Frequency Stability vs. Temperature

		± 30 ppm	± 50 ppm	± 100 ppm		
-20 °C ~ +70 °C	STD.	●	○	○		
-40 °C ~ +85 °C	T1	○	●	○		
-40 °C ~ +105 °C	T2		○	○		
-40 °C ~ +125 °C	T3			○		

● standard
 ○ available

Marking

frequency with load capacitance code
 company code / date code / internal code

date code: year/month
 example: 2A = 2012 January

Jan.	Febr.	Mar.	Apr.	May	June
A	B	C	D	E	F

July	Aug.	Sept.	Oct.	Nov.	Dec.
G	H	J	K	L	M

Dimensions

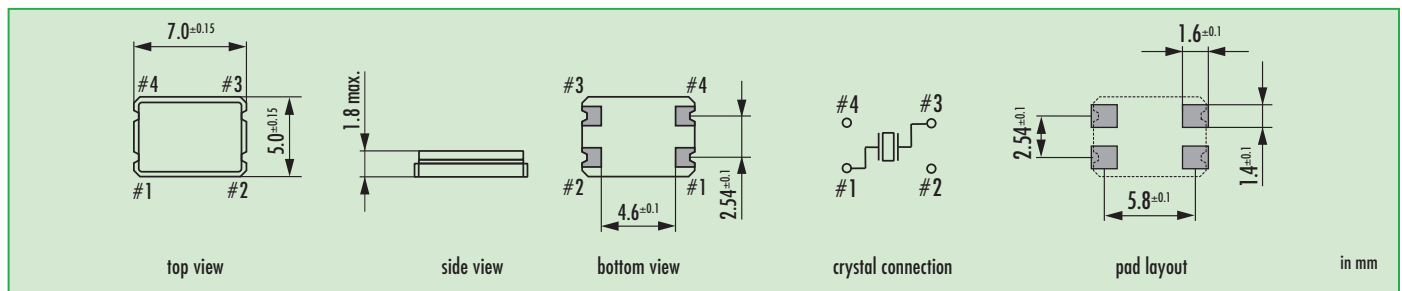

Order Information

Q	frequency	type	load capacitance	stability at 25 °C	stability vs. temp. range	option
Quartz	5.0 ~ 70.0 MHz	JXG75P4	12 pF standard 10 pF ~ 30 pF S for series	30 = ± 30 ppm 50 = ± 50 ppm	30 = ± 30 ppm 50 = ± 50 ppm 100 = ± 100 ppm	blank = -20 °C ~ +70 °C T1 = -40 °C ~ +85 °C T2 = -40 °C ~ +105 °C T3 = -40 °C ~ +125 °C FU = for fundamental frequencies ≥ 20 MHz 3OT = 3rd overtone HMR = High mechanical Resitance (3000g/half sine wave/0.3ms)

Example: Q 28.0-JXG75P4-12-30/30-FU-LF (Suffix LF = RoHS compliant / Pb free pads)



SMD Quartz Crystal · JXG75P4

Taping Specification

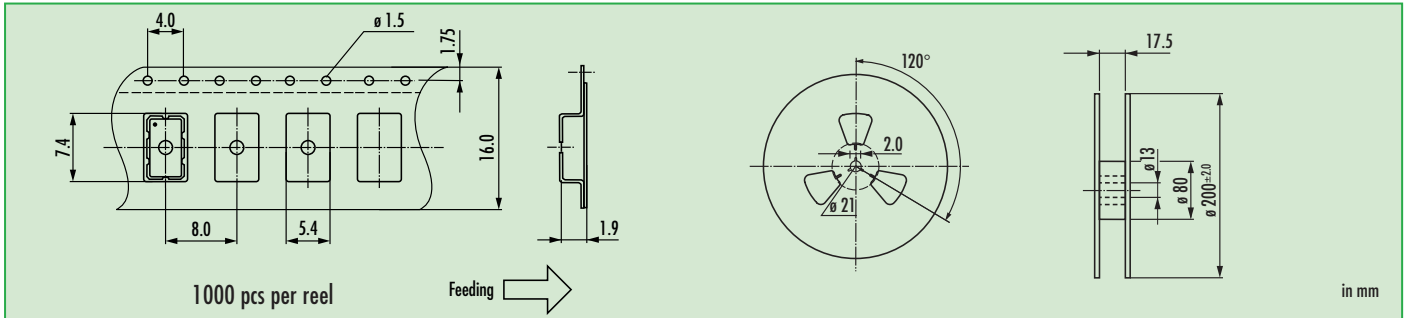

Reflow Soldering Profile

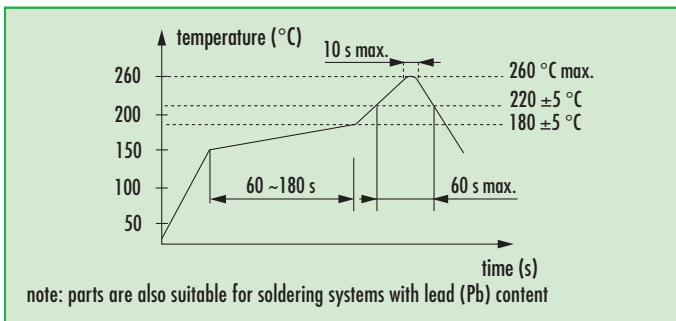

Load Capacitance Codes

8 pF: k	14 pF: x	22 pF: g	series: s
9 pF: n	15 pF: j	24 pF: d	T: 3rd OT
10 pF: h	16 pF: b	25 pF: r	
11 pF: l	17 pF: t	27 pF: w	
12 pF: a	18 pF: f	30 pF: .	
13 pF: v	20 pF: c		

example 8.0 MHz / 12 pF: 8a000





actual size

SMD Quartz Crystal · JXG75P2

2 Pad Version · 7.0 x 5.0 mm

- glass sealed ceramic package
- extended temperature ranges available
- high mechanical reliability type available
- for automotive type, see automotive datasheet



General Data

type	JXG75P2	
frequency range	5.0 ~ 50.0 MHz	(fund. AT-cut)
	30.0 ~ 70.0 MHz	(3rd OT AT-cut)
frequency stability at 25 °C	± 30 ppm, ± 50 ppm	
load capacitance C_L	12 pF standard	(option: 10 pF ~ 30 pF / series)
shunt capacitance C_0	< 7 pF max.	
storage temperature	-40 °C ~ +125 °C	
drive level max.	100 µW (10 µW recommended)	
aging	< ± 3 ppm first year	

ESR (series resistance R_s)

frequency in MHz	vibration mode	ESR max. in Ω	ESR typ. in Ω
5.0 ~ 5.999	fund.-AT	200	120
6.0 ~ 6.999	fund.-AT	100	55
7.0 ~ 9.999	fund.-AT	80	30
10.0 ~ 15.999	fund.-AT	60	20
16.0 ~ 21.999	fund.-AT	50	15
22.0 ~ 39.999	fund.-AT	40	15
40.0 ~ 50.000	fund.-AT	30	11
30.0 ~ 44.999	3rd OT-AT	80	60
45.0 ~ 70.000	3rd OT-AT	70	55

Frequency Stability vs. Temperature

		± 30 ppm	± 50 ppm	± 100 ppm		
-20 °C ~ +70 °C	STD.	●	○	○		
-40 °C ~ +85 °C	T1	○	●	○		
-40 °C ~ +105 °C	T2		○	○		
-40 °C ~ +125 °C	T3			○		

● standard
 ○ available

Marking

frequency with load capacitance code
 company code / date code / internal code

date code: year/month
 example: 2A = 2012 January

Jan.	Febr.	Mar.	Apr.	May	June
A	B	C	D	E	F

July	Aug.	Sept.	Oct.	Nov.	Dec.
G	H	J	K	L	M

Dimensions

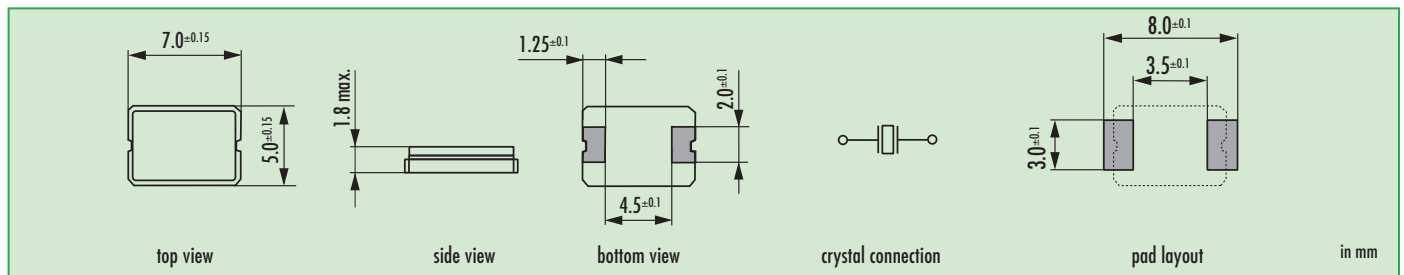

Order Information

Q	frequency	type	load capacitance	stability at 25 °C	stability vs. temp. range	option
Quartz	5.0 ~ 70.0 MHz	JXG75P2	12 pF standard 10 pF ~ 30 pF S for series	30 = ± 30 ppm 50 = ± 50 ppm	30 = ± 30 ppm 50 = ± 50 ppm 100 = ± 100 ppm	blank = -20 °C ~ +70 °C T1 = -40 °C ~ +85 °C T2 = -40 °C ~ +105 °C T3 = -40 °C ~ +125 °C FU = for fundamental frequencies ≥ 20 MHz 30T = 3rd overtone HMR = high mechanical reliability (3000g/half sine wave/0.3ms)

Example: Q 28.0-JXG75P2-12-30/30-FU-LF (Suffix LF = RoHS compliant / Pb free pads)



SMD Quartz Crystal · JXG75P2

Taping Specification

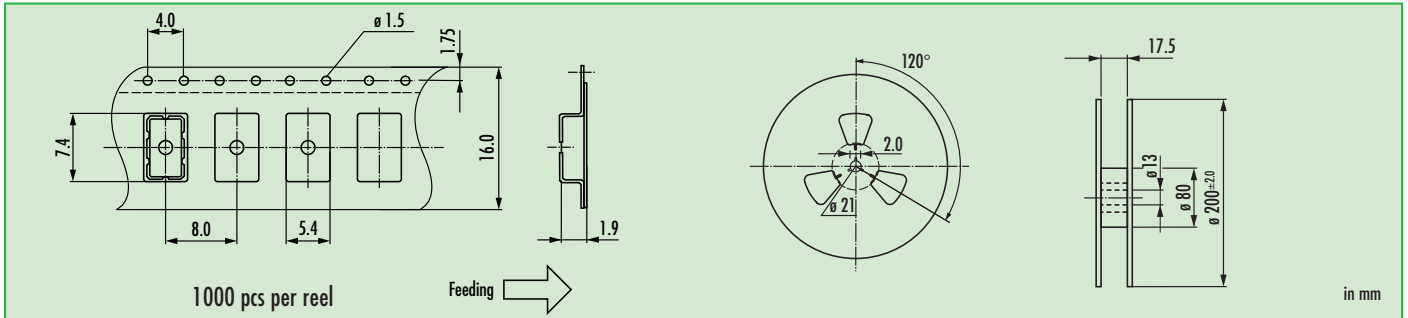

Reflow Soldering Profile

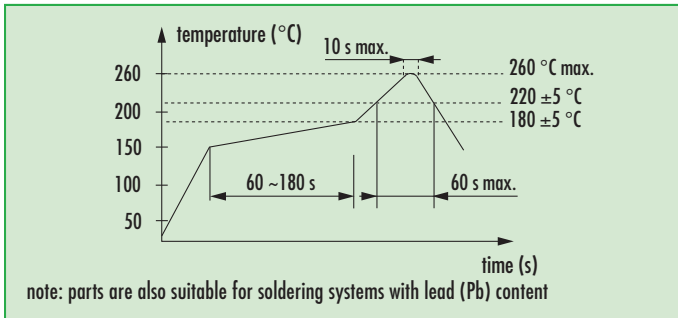

Load Capacitance Codes

8 pF: k	14 pF: x	22 pF: g	series: s
9 pF: n	15 pF: j	24 pF: d	T: 3rd OT
10 pF: h	16 pF: b	25 pF: r	
11 pF: l	17 pF: t	27 pF: w	
12 pF: a	18 pF: f	30 pF: .	
13 pF: v	20 pF: c		

example 8.0 MHz / 12 pF: 8a000





actual size

SMD Quartz Crystal · JXS11

4 Pad Version · 1.6 x 1.2 mm

- ± 10 ppm type available
- EMI shielding possible by grounded lid
- reflow soldering temperature: 260 °C max.
- ceramic / metal package



General Data

type	JXS11
frequency range	24.0 ~ 54.0 MHz (fund. AT-cut)
frequency tolerance at 25 °C	± 10 ppm / ± 20 ppm / ± 30 ppm
load capacitance C_L	8 pF standard (option: 8 pF ~ 30 pF / series)
shunt capacitance C_0	< 5 pF
storage temperature	-40 °C ~ +90 °C
drive level max.	100 µW (10 µW recommended)
aging	< ± 3 ppm first year (option: < ± 1 ppm first year for tol. ± 10 ppm)

ESR (series resistance R_s)

frequency in MHz	vibration mode	ESR max. in Ω	ESR typ. in Ω
24.0 ~ 25.999	fund. AT	200	100
26.0 ~ 29.999	fund. AT	150	70
30.0 ~ 39.999	fund. AT	120	60
40.0 ~ 54.000	fund. AT	60	40

Frequency Stability vs. Temperature

		± 10 ppm	± 15 ppm	± 20 ppm	± 30 ppm	± 50 ppm
-20 °C ~ +70 °C	STD.	○	○	○	●	○
-30 °C ~ +85 °C	T(-30/+85)		○	○	○	○
-40 °C ~ +85 °C	T1			○	○	●

● standard
○ available

Marking

frequency with load capacitance code
company code / date code

date code: year/month
example: 3A = 2013 January

Jan.	Febr.	Mar.	Apr.	May	June
A	B	C	D	E	F

July	Aug.	Sept.	Oct.	Nov.	Dec.
G	H	J	K	L	M

Dimensions

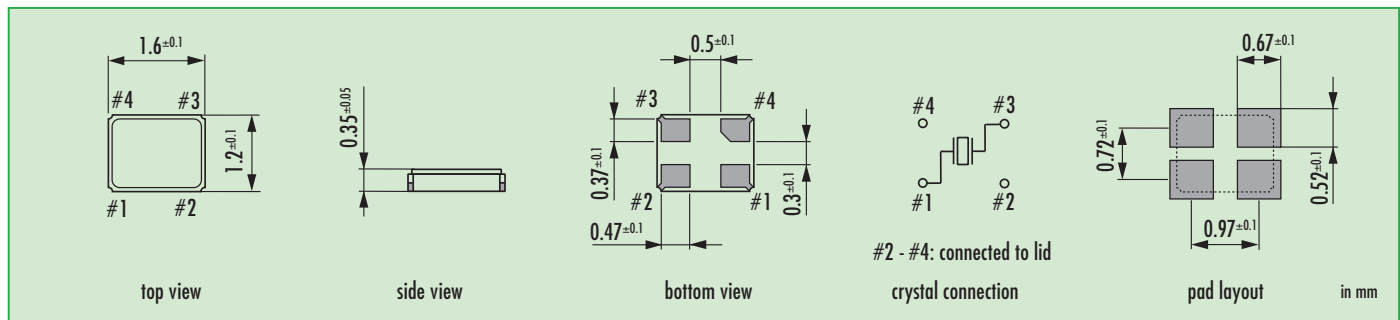

Order Information

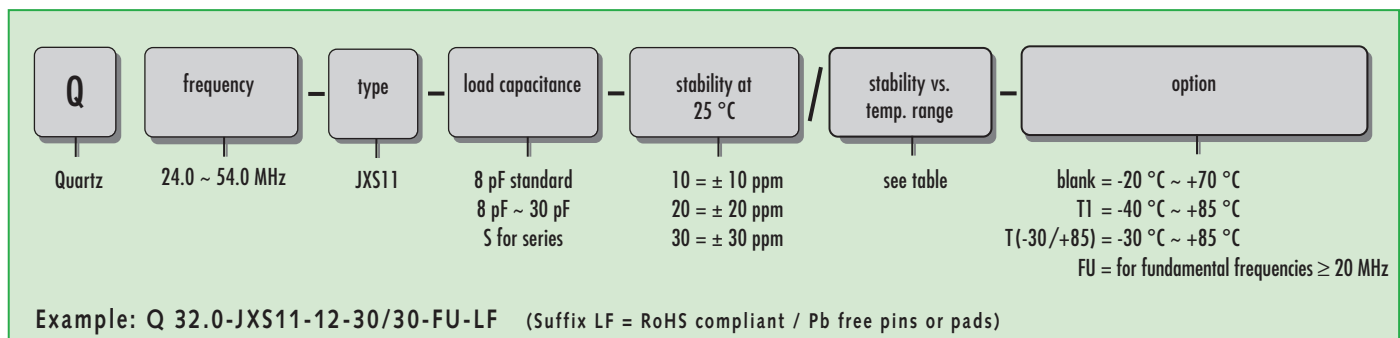

SMD Quartz Crystal · JXS11

Taping Specification

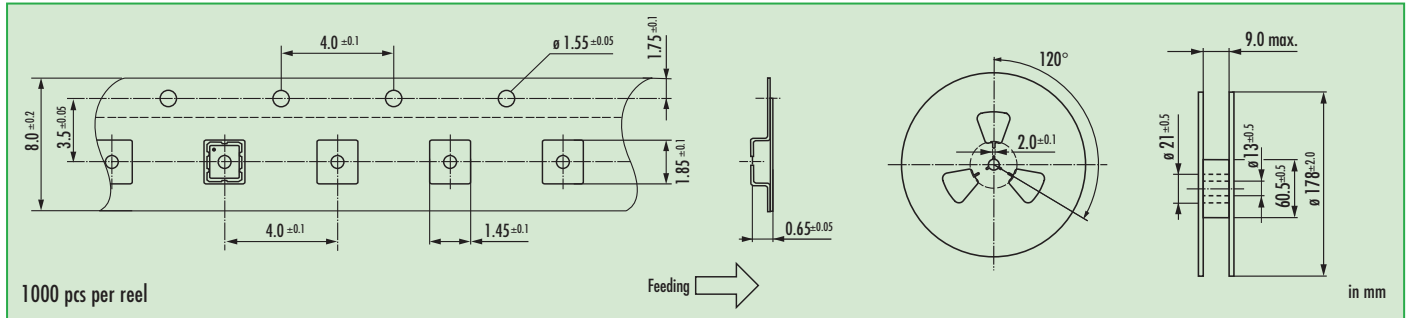

Reflow Soldering Profile

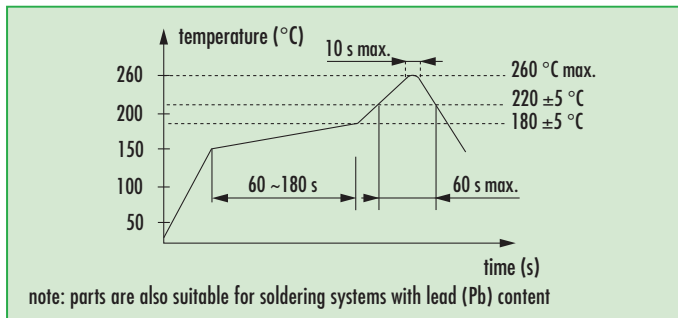

Load Capacitance Codes

8 pF: k	14 pF: x	22 pF: g	series: s
9 pF: n	15 pF: j	24 pF: d	
10 pF: h	16 pF: b	25 pF: r	
11 pF: l	17 pF: t	27 pF: w	
12 pF: a	18 pF: f	30 pF: .	
13 pF: v	20 pF: c		

example 36.0 MHz / 12 pF: 36a0





actual size

SMD Quartz Crystal · JXS21

4 Pad Version · 2.0 x 1.6 mm

- ± 10 ppm type available
- EMI shielding possible by grounded lid
- reflow soldering temperature: 260 °C max.
- ceramic / metal package



General Data

type	JXS21
frequency range	16.0 ~ 54.0 MHz (fund. AT-cut)
frequency tolerance at 25 °C	± 10 ppm / ± 20 ppm / ± 30 ppm
load capacitance C_L	12 pF standard (option: 8 pF ~ 30 pF / series)
shunt capacitance C_0	< 5 pF
storage temperature	-40 °C ~ +90 °C
drive level max.	100 µW (10 µW recommended)
aging	< ± 3 ppm first year (< ± 1 ppm for tol. ± 10 ppm)

ESR (series resistance R_s)

frequency in MHz	vibration mode	ESR max. in Ω	ESR typ. in Ω
16.0 ~ 23.999	fund. - AT	150	120
24.0 ~ 29.999	fund. - AT	100	70
30.0 ~ 35.999	fund. - AT	80	50
36.0 ~ 54.000	fund. - AT	60	40

Frequency Stability vs. Temperature

		± 15 ppm	± 20 ppm	± 30 ppm	± 50 ppm
-20 °C ~ +70 °C	STD.	○	○	●	○
-40 °C ~ +85 °C	T1		○	○	○

● standard
 ○ available

Marking

frequency with load capacitance code
 company code / date code / internal code

date code: year/month
 example: 1A = 2011 January

Jan.	Febr.	Mar.	Apr.	May	June
A	B	C	D	E	F

July	Aug.	Sept.	Oct.	Nov.	Dec.
G	H	J	K	L	M

Dimensions

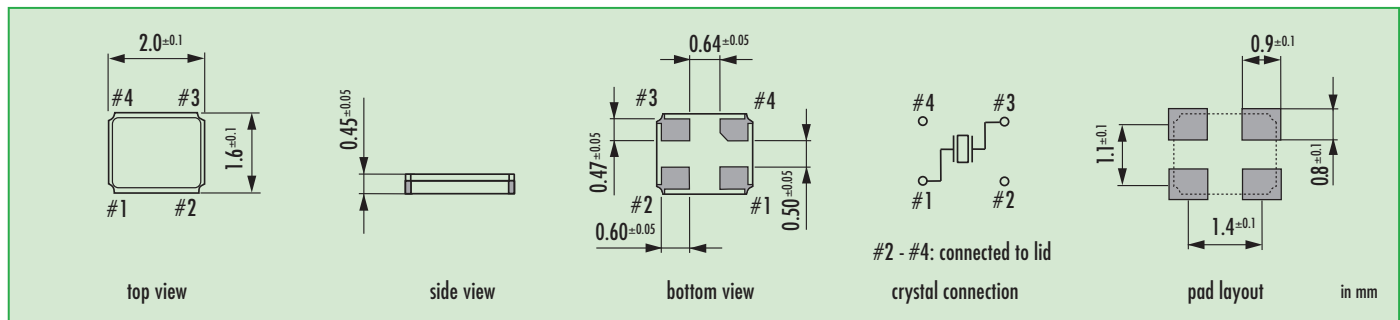

Order Information

Q	frequency	type	load capacitance	stability at 25 °C	stability vs. temp. range	option
Quartz	16.0 ~ 54.0 MHz	JXS21	12 pF standard 8 pF ~ 30 pF 5 for series	10 ± 10 ppm 20 ± 20 ppm 30 ± 30 ppm	see table	blank = -20 °C ~ +70 °C T1 = -40 °C ~ +85 °C FU = for fundamental frequencies ≥ 20 MHz

Example: Q 26.0-JXS21-12-10/20-T1-FU-LF (Suffix LF = RoHS compliant / Pb free pins or pads)



SMD Quartz Crystal · JXS21

Taping Specification

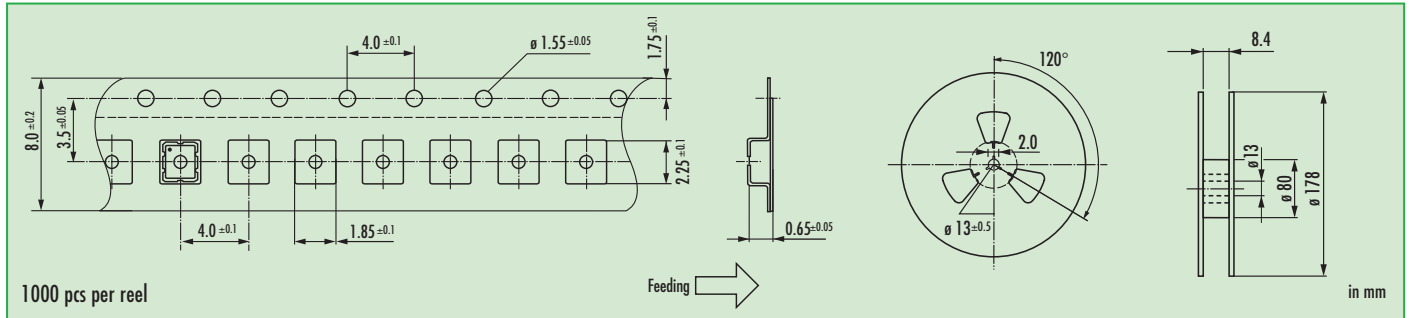

Reflow Soldering Profile

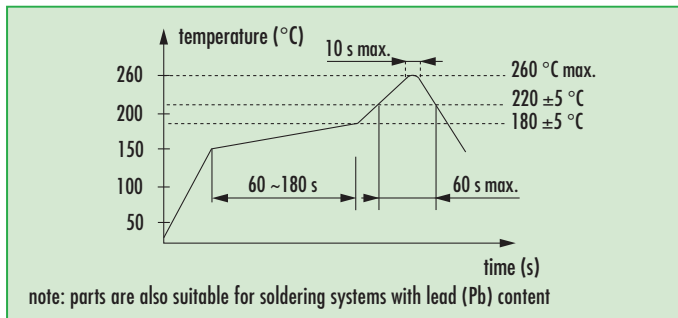

Load Capacitance Codes

8 pF: k	14 pF: x	22 pF: g	series: s
9 pF: n	15 pF: j	24 pF: d	T: 3rd OT
10 pF: h	16 pF: b	25 pF: r	
11 pF: l	17 pF: t	27 pF: w	
12 pF: a	18 pF: f	30 pF: .	
13 pF: v	20 pF: c		

example 20.0 MHz / 12 pF: 20a00

* hand soldering temperature should not exceed 280 °C





actual size

SMD Quartz Crystal · JXS22

4 Pad Version · 2.5 x 2.0 mm

- ± 10 ppm type available
- EMI shielding possible by grounded lid
- reflow soldering temperature: 260 °C max.
- ceramic / metal package



General Data

type	JXS22	
frequency range	12.0 ~ 54.0 MHz	(fund. AT-cut)
frequency tolerance at 25 °C	± 10 ppm / ± 30 ppm	
load capacitance C_L	12 pF standard	(option: 8 pF ~ 30 pF / series)
shunt capacitance C_0	< 5 pF	
storage temperature	-40 °C ~ +90 °C	
drive level max.	100 µW	(10 µW recommended)
aging	< ± 3 ppm first year	(< ± 1 ppm for tol. ± 10 ppm)

ESR (series resistance R_s)

frequency in MHz	vibration mode	ESR max. in Ω	ESR typ. in Ω
12.0 ~ 12.999	fund. - AT	200	170
13.0 ~ 15.999	fund. - AT	150	120
16.0 ~ 18.999	fund. - AT	80	50
19.0 ~ 21.999	fund. - AT	80	40
22.0 ~ 24.999	fund. - AT	70	35
25.0 ~ 29.999	fund. - AT	60	30
30.0 ~ 39.999	fund. - AT	50	25
40.0 ~ 54.000	fund. - AT	50	20

Frequency Stability vs. Temperature

		± 10 ppm	± 15 ppm	± 20 ppm	± 30 ppm	± 50 ppm
-20 °C ~ +70 °C	STD.	●	○	○	●	○
-40 °C ~ +85 °C	T1			○	○	○

● standard
 ○ available

Marking

frequency with load capacitance code
 company code / date code / internal code

date code: year/month
 example: 2A = 2012 January

Jan.	Febr.	Mar.	Apr.	May	June
A	B	C	D	E	F

July	Aug.	Sept.	Oct.	Nov.	Dec.
G	H	J	K	L	M

Dimensions

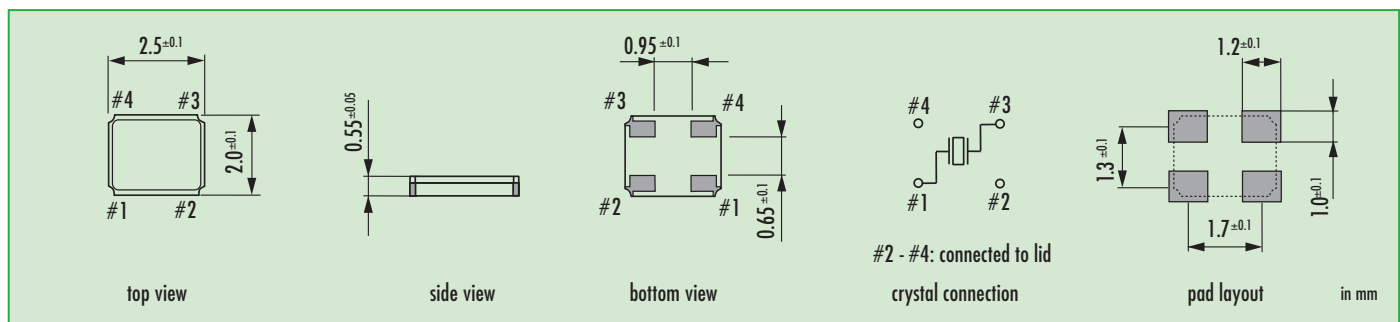

Order Information

Q	frequency	type	load capacitance	stability at 25 °C	stability vs. temp. range	option
Quartz	12.0 ~ 54.0 MHz	JXS22	12 pF standard 8 pF ~ 30 pF S for series	10 ± 10 ppm 30 ± 30 ppm	see table	blank = -20 °C ~ +70 °C T1 = -40 °C ~ +85 °C FU = for fundamental frequencies ≥ 20 MHz

Example: Q 28.0-JXS22-12-30/30-FU-LF (Suffix LF = RoHS compliant / Pb free pins or pads)



SMD Quartz Crystal · JXS22

Taping Specification

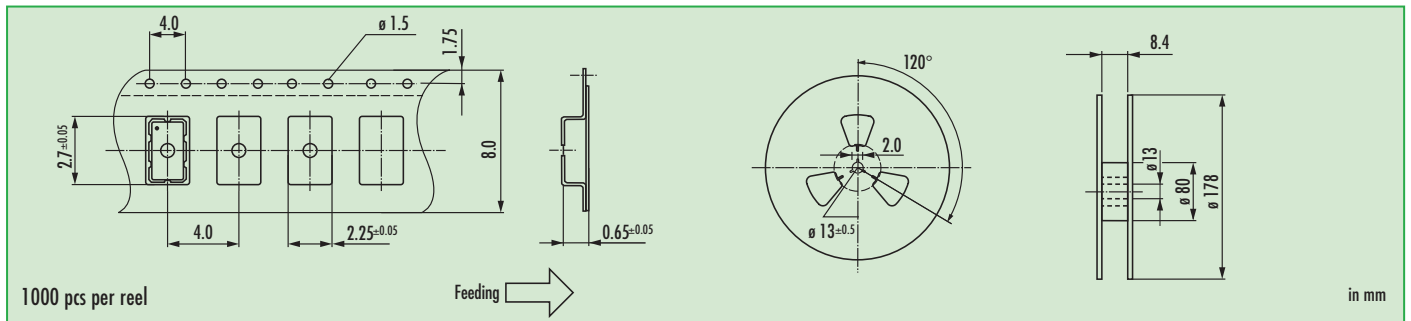

Reflow Soldering Profile

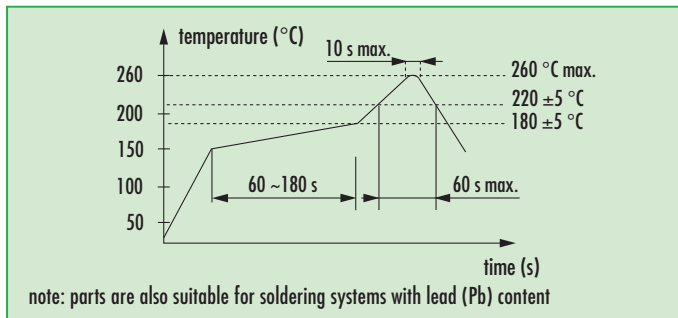

Load Capacitance Codes

8 pF: k	14 pF: x	22 pF: g	series: s
9 pF: n	15 pF: j	24 pF: d	T: 3rd OT
10 pF: h	16 pF: b	25 pF: r	
11 pF: l	17 pF: t	27 pF: w	
12 pF: a	18 pF: f	30 pF: .	
13 pF: v	20 pF: c		

example 20.0 MHz / 12 pF: 20a00





actual size

SMD Quartz Crystal · JXS32

4 Pad Version · 3.2 x 2.5 mm

- seam sealed ceramic/metal package
- extended temperature ranges available
- high mechanical reliability type available
- for automotive type, see automotive datasheet



General Data

type	JXS32
frequency range	10.0 ~ 54.0 MHz (fund. AT-cut)
frequency tolerance at 25 °C	± 10 ppm / ± 30 ppm
load capacitance C_L	12 pF standard (option: 8 pF ~ 30 pF / series)
shunt capacitance C_0	< 5 pF
storage temperature	-40 °C ~ +90 °C
drive level max.	100 µW
aging	< ± 3 ppm first year

ESR (series resistance R_s)

frequency in MHz	vibration mode	ESR max. in Ω	ESR typ. in Ω
10.0 ~ 11.999	fund. - AT	300	150
12.0 ~ 12.999	fund. - AT	100	50
13.0 ~ 15.999	fund. - AT	100	40
16.0 ~ 18.999	fund. - AT	80	40
19.0 ~ 21.999	fund. - AT	70	30
22.0 ~ 29.999	fund. - AT	70	25
30.0 ~ 54.000	fund. - AT	50	20

Frequency Stability vs. Temperature

		± 10 ppm	± 15 ppm	± 20 ppm	± 30 ppm	± 50 ppm	± 100 ppm
-20 °C ~ +70 °C	STD.	●	○*	○	●	○	○
-30 °C ~ +85 °C	T (-30/+85)		□				
-40 °C ~ +85 °C	T1		◇	○	○*	●	○
-40 °C ~ +105 °C	T2					○	○
-40 °C ~ +125 °C	T3					○	○

● standard ○ available ◇ for frequencies > 20 MHz, ask if available < 20 MHz □ for frequencies < 20 MHz
* best value for frequencies < 12.0 MHz

Marking

frequency with load capacitance code
company code / date code / internal code

date code: year/month
example: 2A = 2012 January

Jan.	Febr.	Mar.	Apr.	May	June
A	B	C	D	E	F

July	Aug.	Sept.	Oct.	Nov.	Dec.
G	H	J	K	L	M

Dimensions

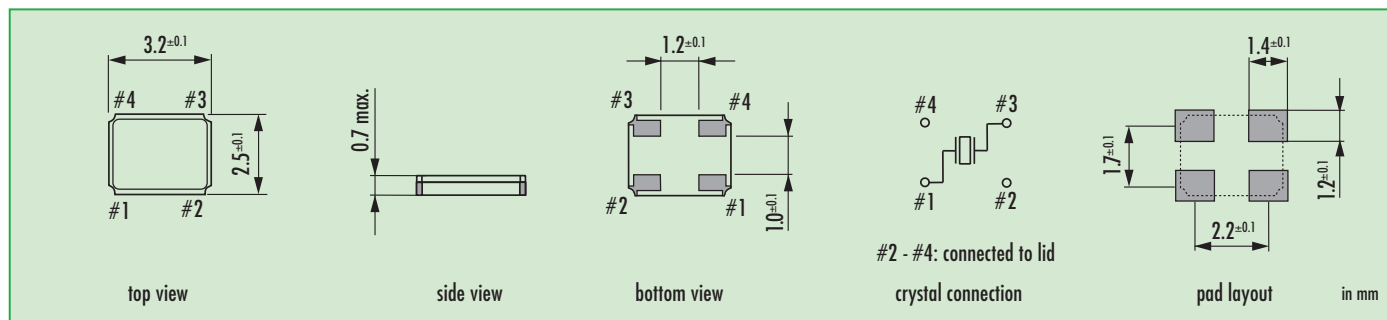

Order Information

Q	frequency	type	load capacitance	stability at 25 °C	stability vs. temp. range	option
Quartz	10.0 ~ 54.0 MHz	JXS32	12 pF standard 8 pF ~ 30 pF S for series	10 = ± 10 ppm 30 = ± 30 ppm	10 = ± 10 ppm 15 = ± 15 ppm 20 = ± 20 ppm 30 = ± 30 ppm 50 = ± 50 ppm 100 = ± 100 ppm	blank = -20 °C ~ +70 °C T (-30/+85) = -30 °C ~ +85 °C T1 = -40 °C ~ +85 °C T2 = -40 °C ~ +105 °C T3 = -40 °C ~ +125 °C FU = for fundamental frequencies ≥ 20 MHz HMR = high mechanical reliability (3000g/half sine wave/0.3ms)

Example: Q 28.0-JXS32-12-30/30-FU-LF (Suffix LF = RoHS compliant / Pb free pins or pads)



SMD Quartz Crystal · JXS32

Taping Specification

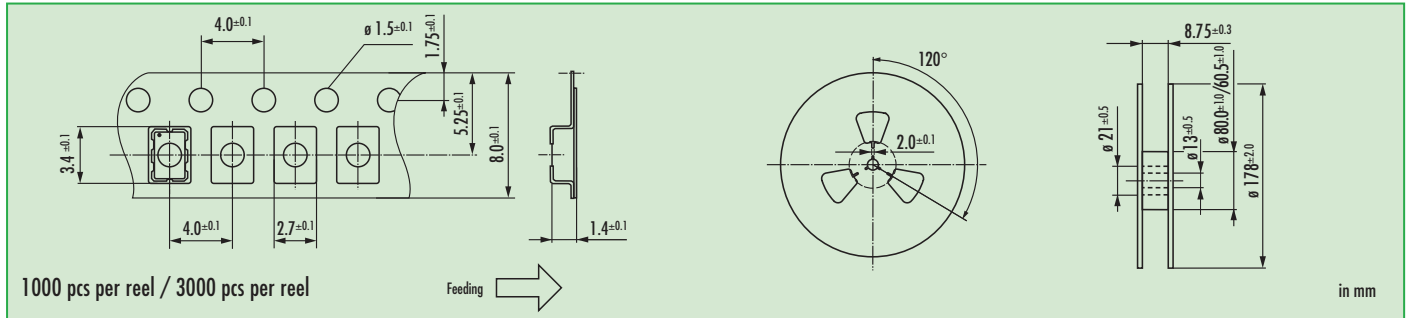

Reflow Soldering Profile

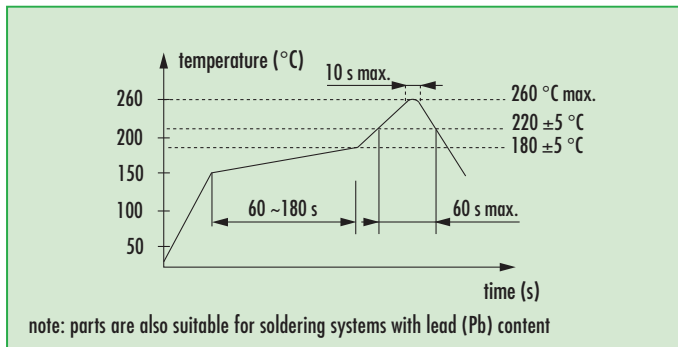

Load Capacitance Codes

8 pF: k	14 pF: x	22 pF: g	series: s
9 pF: n	15 pF: j	24 pF: d	T: 3rd OT
10 pF: h	16 pF: b	25 pF: r	
11 pF: l	17 pF: t	27 pF: w	
12 pF: a	18 pF: f	30 pF: .	
13 pF: v	20 pF: c		

example 20.0 MHz / 12 pF: 20a00





actual size

SMD Quartz Crystal · JXS53

4 Pad Version · 5.0 x 3.2 mm

- seam sealed ceramic/metal package
- extended temperature ranges available
- high mechanical reliability type available
- for automotive type, see automotive datasheet



General Data

type	JXS53	
frequency range	8.0 ~ 56.0 MHz	(fund. AT-cut)
	50.0 ~ 125.0 MHz	(3rd OT AT-cut)
frequency tolerance at 25 °C	± 10 ppm / ± 30 ppm / ± 50 ppm	
load capacitance C_L	12 pF	standard (option 8 pF ~ 32 pF / series)
shunt capacitance C_0	< 7 pF	
storage temperature	-40 °C ~ +125 °C	
drive level max.	100 µW	
aging	< ± 3 ppm first year	(option: < ± 1 ppm first year for tol. ± 10 ppm)

ESR (series resistance R_s)

frequency in MHz	vibration mode	ESR max. in Ω	ESR typ. in Ω
8.0 ~ 9.999	fund. - AT	100	50
10.0 ~ 10.999	fund. - AT	50	30
11.0 ~ 11.999	fund. - AT	40	25
12.0 ~ 21.999	fund. - AT	40	20
22.0 ~ 24.999	fund. - AT	40	15
25.0 ~ 49.999	fund. - AT	30	15
50.0 ~ 56.000	fund. - AT	40	20
50.0 ~ 79.999	3rd OT - AT	100	60
80.0 ~ 125.000	3rd OT - AT	80	60

Frequency Stability vs. Temperature

		± 10 ppm	± 15 ppm	± 20 ppm	± 30 ppm	± 50 ppm	± 100 ppm
-20 °C ~ +70 °C	STD.	○	○	○	○	○	○
-40 °C ~ +85 °C	T1		○	○	○	○	○
-40 °C ~ +105 °C	T2					○	○
-40 °C ~ +125 °C	T3						○

○ available

Marking

frequency with load capacitance code
company code / date code / internal code

date code: year/month
example: 2A = 2012 January

Jan.	Febr.	Mar.	Apr.	May	June
A	B	C	D	E	F

July	Aug.	Sept.	Oct.	Nov.	Dec.
G	H	J	K	L	M

Dimensions

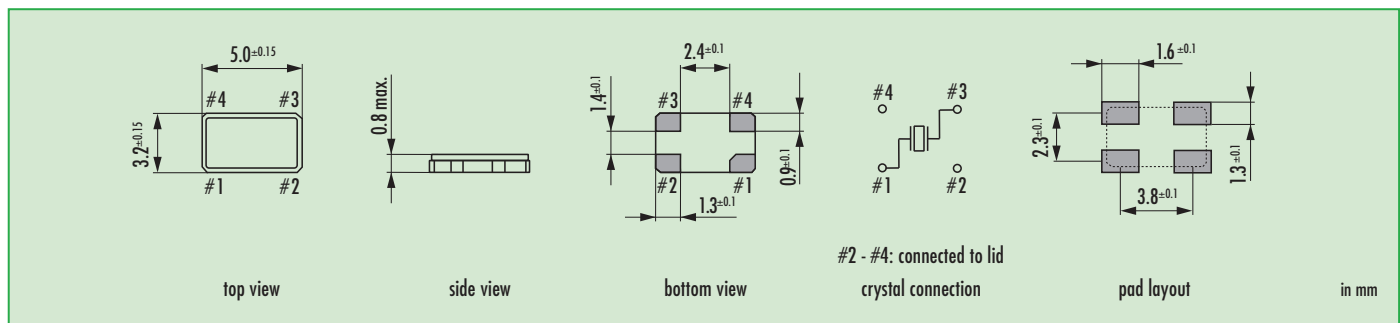

Order Information

Q	frequency	type	load capacitance	stability at 25 °C	stability vs. temp. range	option
Quartz	8.0 ~ 125.0 MHz	JXS53	12 pF standard 8 pF ~ 30 pF S for series	10 = ± 10 ppm 30 = ± 30 ppm 50 = ± 50 ppm	10 = ± 10 ppm 15 = ± 15 ppm 20 = ± 20 ppm 30 = ± 30 ppm 50 = ± 50 ppm 100 = ± 100 ppm	blank = -20 °C ~ +70 °C T1 = -40 °C ~ +85 °C T2 = -40 °C ~ +105 °C T3 = -40 °C ~ +125 °C FU = for fundamental frequencies ≥ 20 MHz 30T = 3rd overtone HMR = high mechanical reliability (3000g/half sine wave/0.3ms)

Example: Q 30.0-JXS53-12-30/30-FU-LF (Suffix LF = RoHS compliant / Pb free pins or pads)



SMD Quartz Crystal · JXS53

Taping Specification

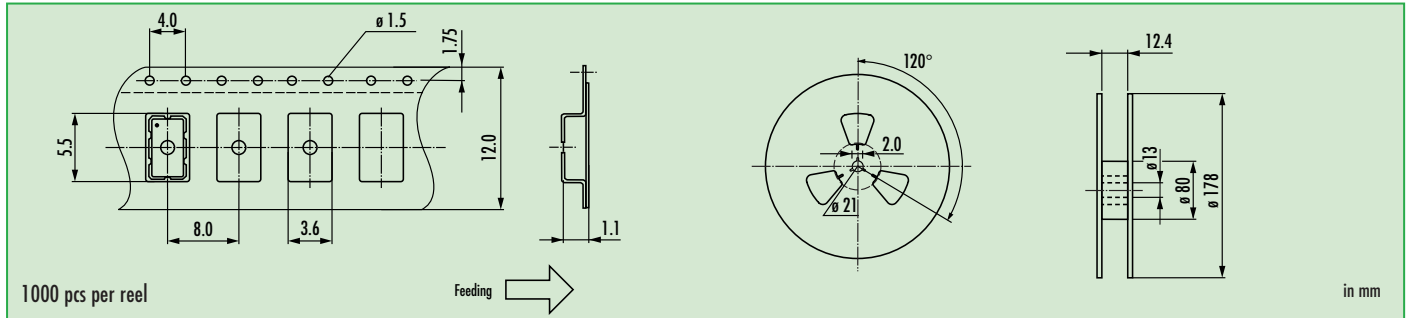

Reflow Soldering Profile

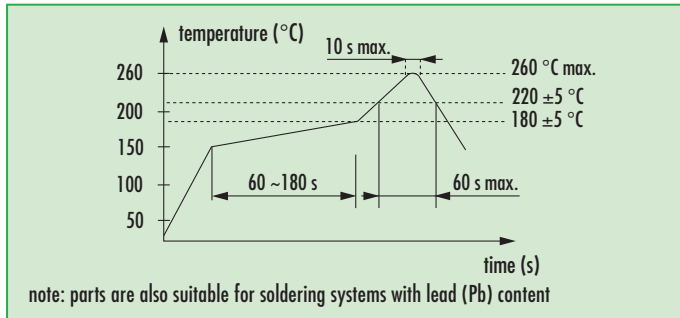

Load Capacitance Codes

8 pF: k	14 pF: x	22 pF: g	series: s
9 pF: n	15 pF: j	24 pF: d	T: 3rd OT
10 pF: h	16 pF: b	25 pF: r	
11 pF: l	17 pF: t	27 pF: w	
12 pF: a	18 pF: f	30 pF: .	
13 pF: v	20 pF: c		

example 20.0 MHz / 12 pF: 20a00





actual size

SMD Quartz Crystal · JXS63

4 Pad Version · 6.0 x 3.5 mm

- ± 10 ppm type available
- ceramic / metal package
- wave soldering temperature: 260 °C max.



General Data

type	JXS63	
frequency range	9.0 ~ 50.0 MHz	(fund. AT-cut)
frequency tolerance at 25 °C	± 10 ppm / ± 30 ppm	
load capacitance C_L	12 pF standard	(option 8 pF ~ 30 pF / series)
shunt capacitance C_0	< 7 pF	
storage temperature	-40 °C ~ +90 °C	
drive level max.	100 µW	
aging	< ± 3 ppm first year	

ESR (series resistance R_s)

frequency in MHz	vibration mode	ESR max. in Ω	ESR typ. in Ω
9.00 ~ 9.999	fund. - AT	60	35
10.0 ~ 10.999	fund. - AT	50	25
11.0 ~ 11.999	fund. - AT	40	20
12.0 ~ 24.999	fund. - AT	40	15
25.0 ~ 50.000	fund. - AT	30	15

Frequency Stability vs. temperature

		± 10 ppm	± 15 ppm	± 20 ppm	± 30 ppm	± 50 ppm
-20 °C ~ +70 °C	STD.	○	○	○	●	○
-40 °C ~ +85 °C	T1		○	○	○	●

● standard
○ available

Marking

frequency with load capacitance code
company code / date code / internal code

date code: year/month
example: 3A = 2013 January

Jan.	Febr.	Mar.	Apr.	May	June
A	B	C	D	E	F

July	Aug.	Sept.	Oct.	Nov.	Dec.
G	H	J	K	L	M

Dimensions

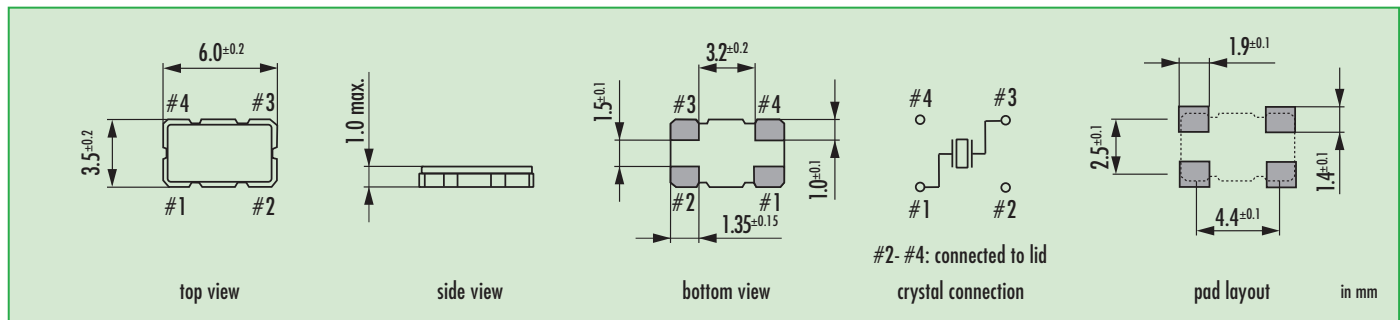

Order Information

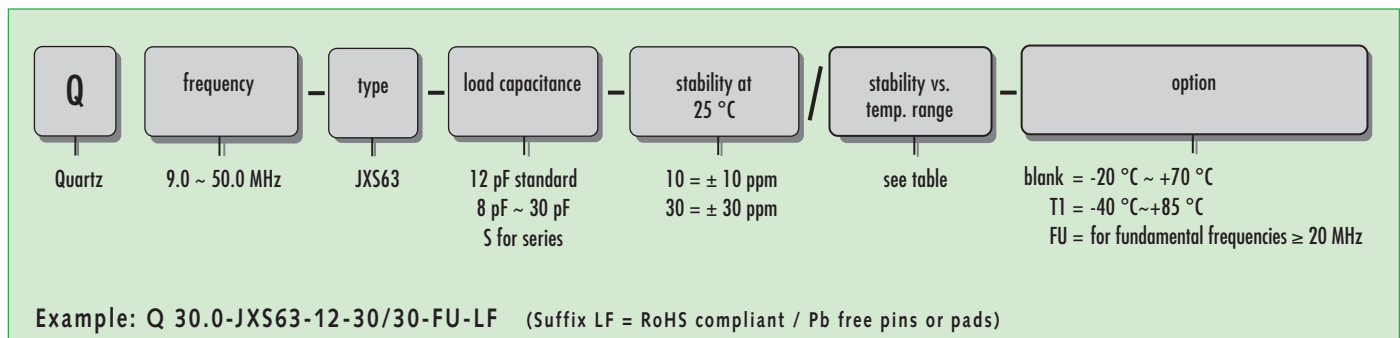

SMD Quartz Crystal · JXS63

Taping Specification

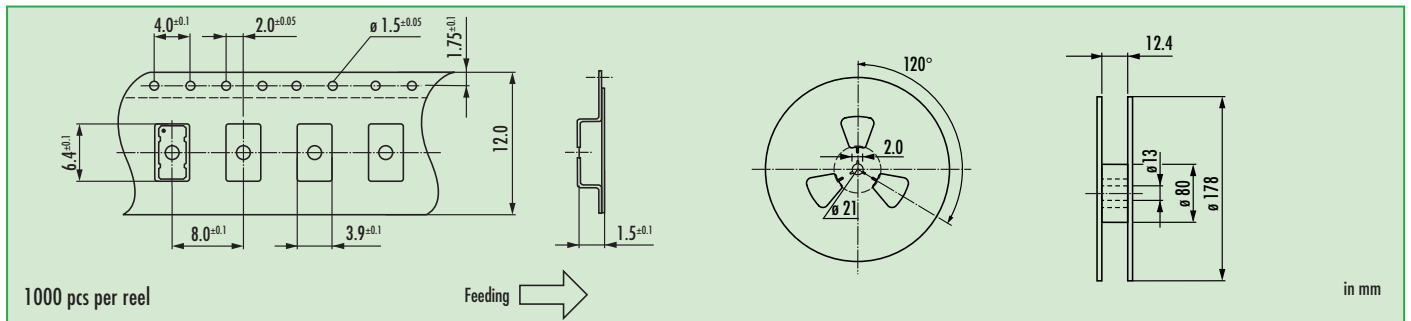

Reflow Soldering Profile

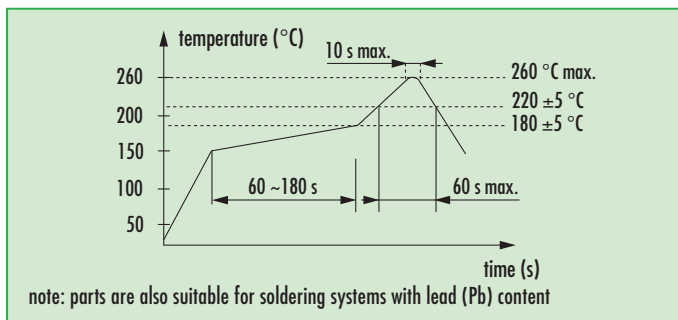

Load Capacitance Codes

8 pF: k	14 pF: x	22 pF: g	series: s
9 pF: n	15 pF: j	24 pF: d	T: 3rd OT
10 pF: h	16 pF: b	25 pF: r	
11 pF: l	17 pF: t	27 pF: w	
12 pF: a	18 pF: f	30 pF: .	
13 pF: v	20 pF: c		

example 20.0 MHz / 12 pF: 20a00





actual size

SMD Quartz Crystal · JXS75

4 Pad Version · 7.5 x 5.2 mm

- ± 10 ppm type available
- EMI shielding possible by grounded lid
- reflow soldering temperature: 260 °C max.
- ceramic / metal package



General Data

type	JXS75	
frequency range	5.53 ~ 54.0 MHz	(fund. AT-cut)
	24.00 ~ 150.0 MHz	(3rd OT AT-cut)
	60.00 ~ 170.0 MHz	(fund. AT-cut) on request
frequency tolerance at 25 °C	± 10 ppm ~ ± 30 ppm	
load capacitance C_L	12 pF standard	(option 8 pF ~ 30 pF / series)
shunt capacitance C_0	< 7 pF	
storage temperature	-40 °C ~ +90 °C	
drive level max.	100 µW	
aging	< ± 3 ppm first year	

ESR (series resistance R_s)

frequency in MHz	vibration mode	ESR max. in Ω	ESR typ. in Ω
5.53 ~ 5.99	fund.- AT	150	80
6.0 ~ 6.99	fund.- AT	100	60
7.0 ~ 9.99	fund.- AT	80	20
10.0 ~ 15.99	fund.- AT	60	20
16.0 ~ 21.99	fund.- AT	50	15
22.0 ~ 24.99	fund.- AT	40	15
25.0 ~ 54.00	fund.- AT	30	15
24.0 ~ 150.00	3rd OT - AT	on request	on request

Frequency Stability vs. Temperature

		± 10 ppm	± 15 ppm	± 20 ppm	± 30 ppm	± 50 ppm	100 ppm
-20 °C ~ +70 °C	STD.	○	○	○	●	○	○
-40 °C ~ +85 °C	T1		○	○	○	○	○

● standard
 ○ available

Marking

frequency with load capacitance code
 company code / date code / internal code

date code: year/month
 example: 3A = 2013 January

Jan.	Febr.	Mar.	Apr.	May	June
A	B	C	D	E	F

July	Aug.	Sept.	Oct.	Nov.	Dec.
G	H	J	K	L	M

Dimensions

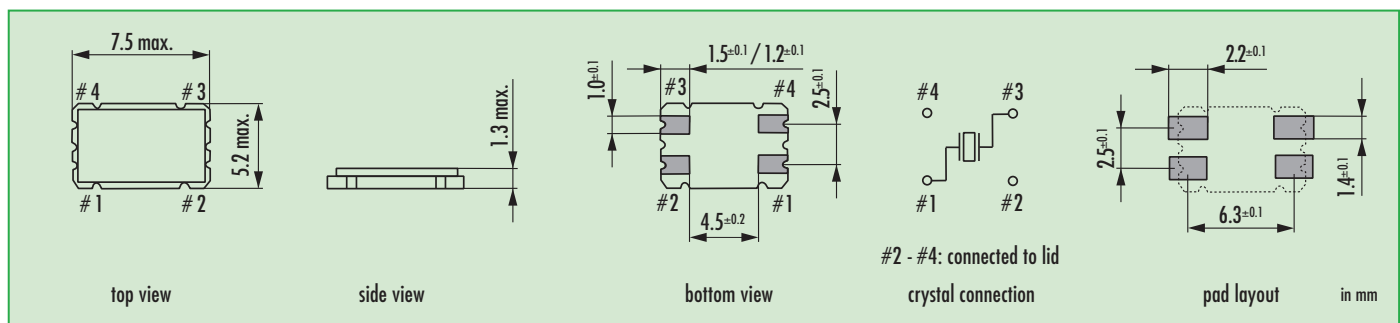

Order Information

Q	frequency	type	load capacitance	stability at 25 °C	stability vs. temp. range	option
Quartz	5.53 ~ 170.0 MHz	JXS75	12 pF standard 8 pF ~ 30 pF S for series	10 = ± 10 ppm 30 = ± 30 ppm	see table	blank = -20 °C ~ +70 °C T1 = -40 °C ~ +85 °C FU = for fundamental frequencies ≥ 20 MHz 30T = 3rd overtone

Example: Q 28.0-JXS75-12-30/30-FU (Suffix LF = RoHS compliant / Pb free pins or pads)



SMD Quartz Crystal · JXS75

Taping Specification

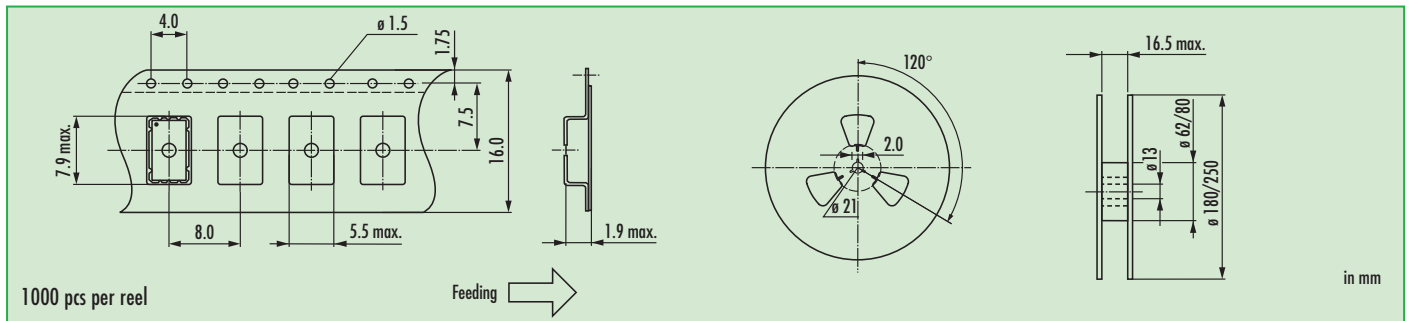

Reflow Soldering Profile

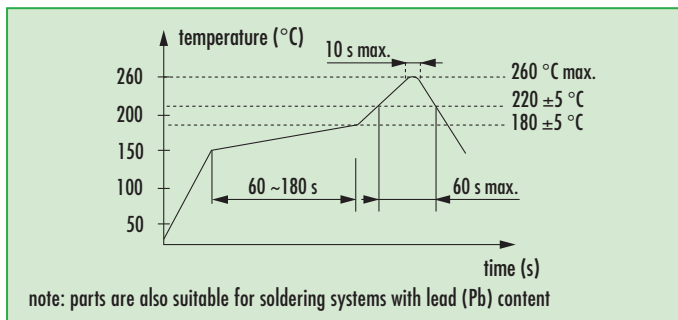

Load Capacitance Codes

8 pF: k	14 pF: x	22 pF: g	series: s
9 pF: n	15 pF: j	24 pF: d	T: 3rd OT
10 pF: h	16 pF: b	25 pF: r	
11 pF: l	17 pF: t	27 pF: w	
12 pF: a	18 pF: f	30 pF: .	
13 pF: v	20 pF: c		

example 20.0 MHz / 12 pF: 20a00





actual size

SMD Quartz Crystal · SMU2

2 Pad Version · 11.5 x 4.8 mm

- for automotive type, see automotive datasheet
- extended temperature ranges available
- reflow soldering temperature: 260 °C max.
- package height 3.0 mm max.



General Data

type		SMU2
frequency range	fund. AT-cut	4.0 ~ 33.0 MHz
	3rd OT AT-cut	ask for availability
	fund. BT-cut	ask for availability
frequency tolerance at 25 °C		± 20 ppm / ± 30 ppm / ± 50 ppm
load capacitance C_L		12 pF ~ 32 pF or series
shunt capacitance C_0		< 5 pF
storage temperature		-40 °C ~ +125 °C
shock resistance		> 100 g (half sine pulse, 0.6 ms)
drive level max.		500 µW (100 µW recommended)
aging		< ± 5 ppm first year

ESR (series resistance R_s)

frequency in MHz	vibration mode	ESR max. in Ω	ESR typ. in Ω
4.0 ~ 5.999	fund. AT	80	60
6.0 ~ 6.999	fund. AT	70	35
7.0 ~ 7.999	fund. AT	50	25
8.0 ~ 8.999	fund. AT	50	25
9.0 ~ 13.999	fund. AT	35	15
14.0 ~ 33.000	fund. AT	30	10
ask	3rd OT AT	(100)	(60)
ask	fund. BT	(50)	(20)

Frequency Stability vs. Temperature

		± 20 ppm	± 30 ppm	± 50 ppm	± 100 ppm	± 150 ppm	+10/-100 ppm
-20 °C ~ +70 °C	STD	D	○	●			○ BT-cut
-40 °C ~ +85 °C	T1		○	○	●		
-40 °C ~ +105 °C	T2			○	○		
-40 °C ~ +125 °C	T3					○	

● standard ○ available D ask, if available

Automotive application note

- automotive quartz crystals have superior environmental performance in case of shock, vibration and temperature
- extended operating temperatures up to +125 °C
- production is certified according to: ISO 9001 / TS 16949 / ISO 14001

Dimensions

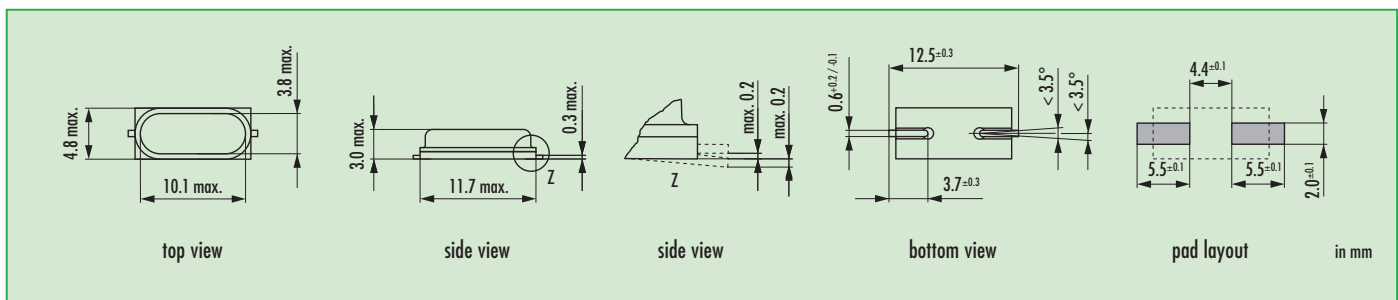

Order Information

Q	frequency	type	load capacitance in pF	stability at 25 °C	stability vs. temp. range	option
Quartz	4.0 ~ 33.0 MHz	SMU2	12 pF ~ 32 pF S for series	30 = ± 30 ppm std 20 = ± 20 ppm 50 = ± 50 ppm	see table	blank = -20 °C ~ +70 °C T1 = -40 °C ~ +85 °C T2 = -40 °C ~ +105 °C T3 = -40 °C ~ +125 °C FU = for fundamental frequencies ≥ 20 MHz 30T = 3rd overtone (if available) BT = fundamental BT-cut (if available)

Example: Q 25.0-SMU2-30-30/50-FU-LF (Suffix LF = RoHS compliant / Pb free pins or pads)



SMD Quartz Crystal · SMU2

Taping Specification

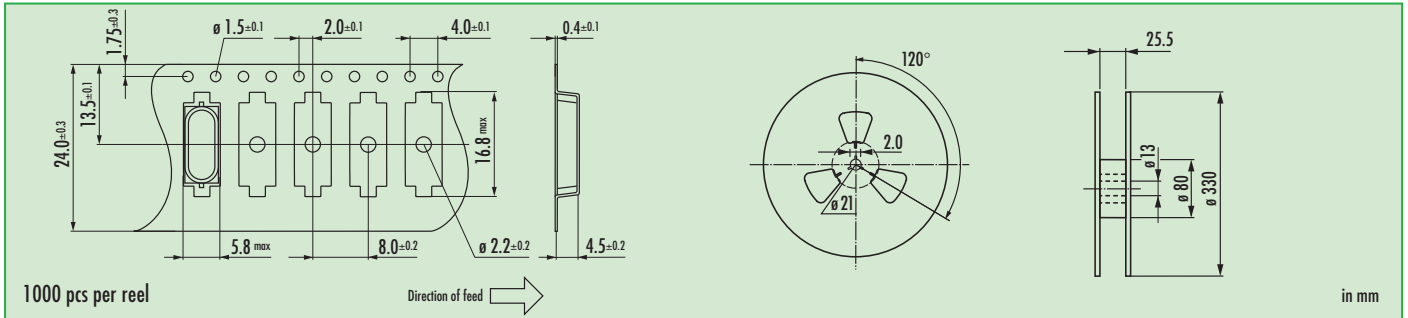

Reflow Soldering Profile

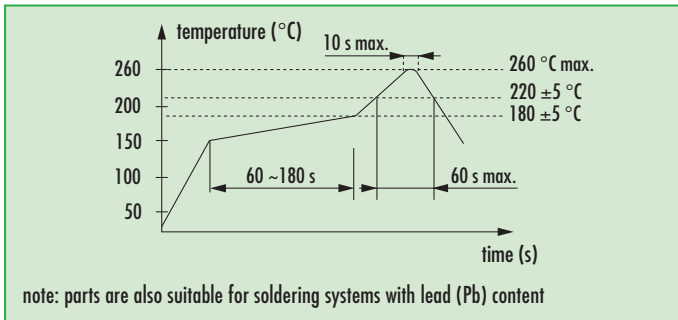

Load Capacitance Codes

7 pF: m	13 pF: v	20 pF: c	32 pF: e
8 pF: k	14 pF: x	22 pF: g	series: s
9 pF: n	15 pF: j	24 pF: d	T: 3rd OT
10 pF: h	16 pF: b	25 pF: r	
11 pF: l	17 pF: t	27 pF: w	
12 pF: a	18 pF: f	30 pF: .	

example 10.0 MHz / 12 pF: 10a000

Marking

frequency with load capacitance code
company code / date code / internal code

	Jan.	Feb.	Mar.	Apr.	May	Jun.	Jul.	Aug.	Sept.	Oct.	Nov.	Dec.
2011 2015	a	b	c	d	e	f	g	h	i	k	l	m
2012 2016	n	p	q	r	s	t	u	v	w	x	y	z
2013 2017	A	B	C	D	E	F	G	H	J	K	L	M
2014 2018	N	P	Q	R	S	T	U	V	W	X	Y	Z



B.C.E. s.r.l.
Via Regina Pacis, 54/c - 41049 SASSUOLO (MO) Italy
Tel. +39 0536 811.616 r.a. - Fax +39 0536 811.500
www.bce.it - E-mail: bce@bce.it





actual size

SMD Quartz Crystal · SMU3

2 Pad Version · 11.5 x 4.8 mm

- for automotive type, see automotive datasheet
- extended temperature ranges available
- reflow soldering temperature: 260 °C max.
- package height 4.0 mm max.



General Data

type		SMU3
frequency range	fund. AT-cut	3.27680 ~ 33.0 MHz
	3rd OT AT-cut	ask for availability
	fund. BT-cut	ask for availability
frequency tolerance at 25 °C		± 20 ppm ~ ± 50 ppm / ± 50 ppm if ≤ 3.57 MHz
load capacitance C_L		12 pF ~ 32 pF or series
shunt capacitance C_0		< 5 pF
storage temperature		-40 °C ~ +125 °C
shock resistance		> 100 g (half sine pulse, 0.6 ms)
drive level max.		500 µW (100 µW recommended)
aging		< ± 5 ppm first year

ESR (series resistance R_s)

frequency in MHz	vibration mode	ESR max. in Ω	ESR typ. in Ω
3.276 ~ 3.499	fund. AT	200	100
3.500 ~ 3.999	fund. AT	120	80
4.000 ~ 5.999	fund. AT	80	60
6.000 ~ 6.999	fund. AT	70	35
7.000 ~ 8.999	fund. AT	50	25
9.000 ~ 13.999	fund. AT	35	15
14.000 ~ 33.000	fund. AT	30	10
ask	3rd OT AT	(100)	(60)
ask	fund. BT	(50)	(20)

numbers in brackets () only for reference

Frequency Stability vs. Temperature

		± 20 ppm	± 30 ppm	± 50 ppm	± 100 ppm	± 150 ppm	+10/-100 ppm
-20 °C ~ +70 °C	STD	D	○	●			○ BT-cut
-40 °C ~ +85 °C	T1		○	● (*)	○		
-40 °C ~ +105 °C	T2			○	○		
-40 °C ~ +125 °C	T3					○	

● standard ○ available D ask, if available (*) if ≤ 3.57 MHz, not better than ± 100 ppm at temp. range T1

Automotive application note

- automotive quartz crystals have superior environmental performance in case of shock, vibration and temperature
- extended operating temperatures up to +125 °C
- production is certified according to: ISO 9001 / TS 16949 / ISO 14001

Dimensions

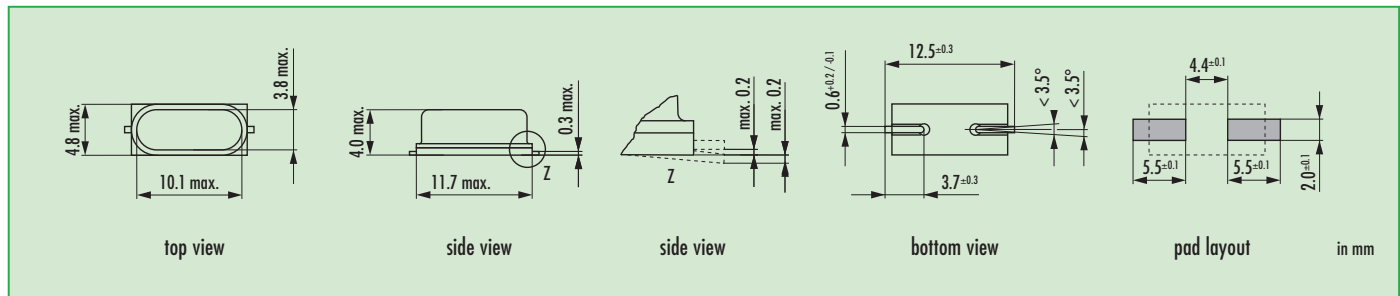

Order Information

Q	frequency	type	load capacitance in pF	stability at 25 °C	stability vs. temp. range	option
Quartz	3.27680 ~ 33.0 MHz	SMU3	12 pF ~ 32 pF S for series 30 pF standard	30 = ± 30 ppm std 20 = ± 20 ppm 50 = ± 50 ppm	see table	blank = -20 °C ~ +70 °C T1 = -40 °C ~ +85 °C T2 = -40 °C ~ +105 °C T3 = -40 °C ~ +125 °C FU = for fundamental frequencies ≥ 20 MHz 30T = 3rd overtone (if available) BT = fundamental BT-cut (if available)

Example: Q 30.0-SMU3-30-30/50-T1-FU-LF (Suffix LF = RoHS compliant / Pb free pins or pads) BT = fundamental BT-cut (if available)



SMD Quartz Crystal · SMU3 · Automotive Applications

Taping Specification

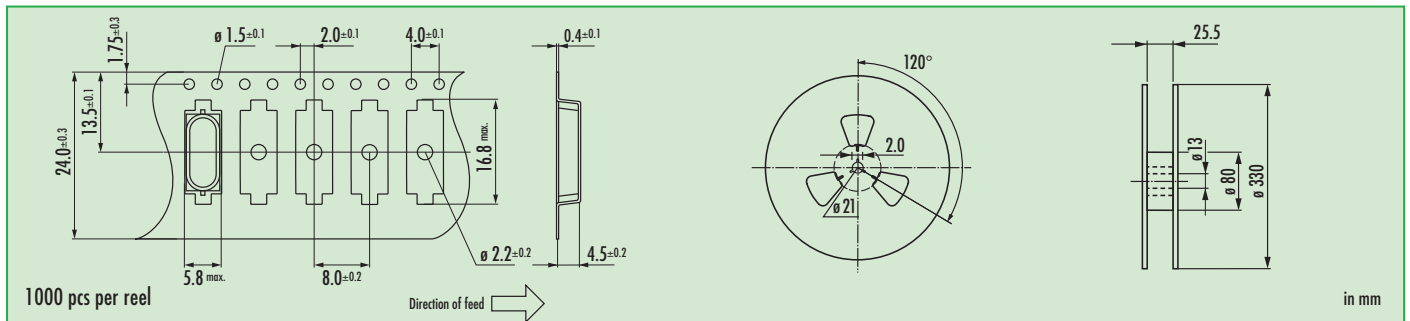

Reflow Soldering Profile

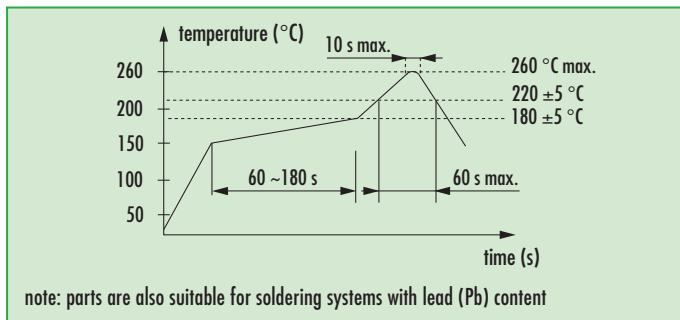

Load Capacitance Codes

7 pF: m	13 pF: v	20 pF: c	32 pF: e
8 pF: k	14 pF: x	22 pF: g	series: s
9 pF: n	15 pF: j	24 pF: d	T: 3rd OT
10 pF: h	16 pF: b	25 pF: r	
11 pF: l	17 pF: t	27 pF: w	
12 pF: a	18 pF: f	30 pF: .	

example 4.0 MHz / 12 pF: 4a000

Marking

frequency with load capacitance code
company code / date code / internal code

	Jan.	Feb.	Mar.	Apr.	May	Jun.	Jul.	Aug.	Sept.	Oct.	Nov.	Dec.
2011 2015	a	b	c	d	e	f	g	h	i	k	l	m
2012 2016	n	p	q	r	s	t	u	v	w	x	y	z
2013 2017	A	B	C	D	E	F	G	H	J	K	L	M
2014 2018	N	P	Q	R	S	T	U	V	W	X	Y	Z



B.C.E. s.r.l.
Via Regina Pacis, 54/c - 41049 SASSUOLO (MO) Italy
Tel. +39 0536 811.616 r.a. - Fax +39 0536 811.500
www.bce.it - E-mail: bce@bce.it





actual size

SMD Quartz Crystal · SMU4

2 Pad Version · 11.5 x 4.8 mm

- low cost SMD type
- reflow soldering temperature: 260 °C max.
- package height 4.0 mm max.



General Data

type		SMU4
frequency range	fund. AT-cut	3.27680 ~ 33.0 MHz (> 33.0 MHz, ask if available)
	3rd OT AT-cut	ask for availability
	fund. BT-cut	ask for availability
frequency tolerance at 25 °C		± 20 ppm ~ ± 50 ppm / ± 50 ppm if ≤ 3.57 MHz
load capacitance C_L		12 pF ~ 32 pF or series / 30 pF standard
shunt capacitance C_0		< 5 pF
storage temperature		-40 °C ~ +125 °C
drive level max.		500 µW (100 µW recommended)
aging		< ± 5 ppm first year

ESR (series resistance R_s)

frequency in MHz	vibration mode	ESR max. in Ω	ESR typ. in Ω
3.276 ~ 3.499	fund. AT	200	100
3.500 ~ 3.999	fund. AT	120	80
4.000 ~ 5.999	fund. AT	80	60
6.000 ~ 6.999	fund. AT	70	35
7.000 ~ 8.999	fund. AT	50	25
9.000 ~ 13.999	fund. AT	35	15
14.000 ~ 33.000	fund. AT	30	10
(33.000 ~ 40.000)	fund. AT	(30)	(10)
ask	3rd OT AT	(100)	(60)
ask	fund. BT	(50)	(20)

numbers in brackets () only for reference

Frequency Stability vs. Temperature

		± 20 ppm	± 30 ppm	± 50 ppm	± 100 ppm	± 150 ppm	+10/-100 ppm
-20 °C ~ +70 °C	STD	D	●	●			○ BT-cut
-40 °C ~ +85 °C	T1		○	○ (*)	●		

● standard ○ available D ask, if available (*) if ≤ 3.57 MHz, not better than ± 100 ppm at temp. range T1

Dimensions

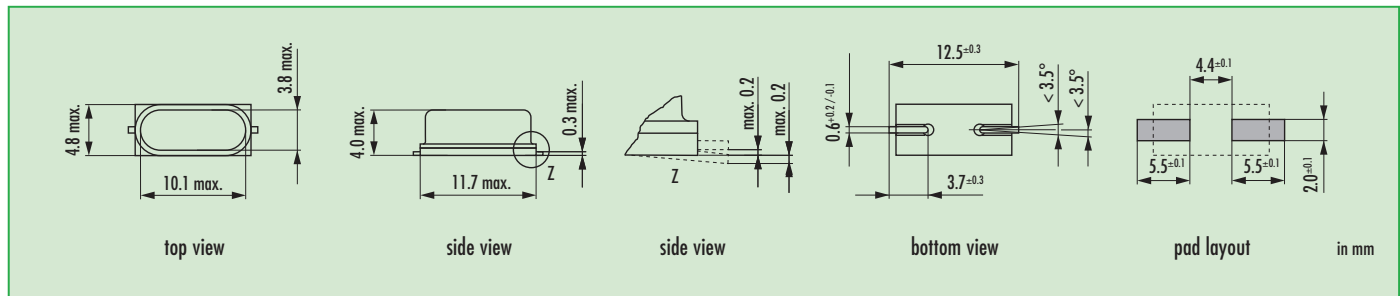

Order Information

Q	frequency	type	load capacitance in pF	stability at 25 °C	stability vs. temp. range	option
Quartz	3.27680 ~ 33.0 MHz	SMU4	12 pF ~ 32 pF S for series 30 pF standard	30 = ± 30 ppm std 20 = ± 20 ppm 50 = ± 50 ppm	see table	blank = -20 °C ~ +70 °C T1 = -40 °C ~ +85 °C FU = for fundamental frequencies ≥ 20 MHz 30T = 3rd overtone (if available) BT = fundamental BT-cut (if available)

Example: Q 30.0-SMU4-30-30/50-T1-FU-LF (Suffix LF = RoHS compliant / Pb free pins or pads)



SMD Quartz Crystal · SMU4

Taping Specification

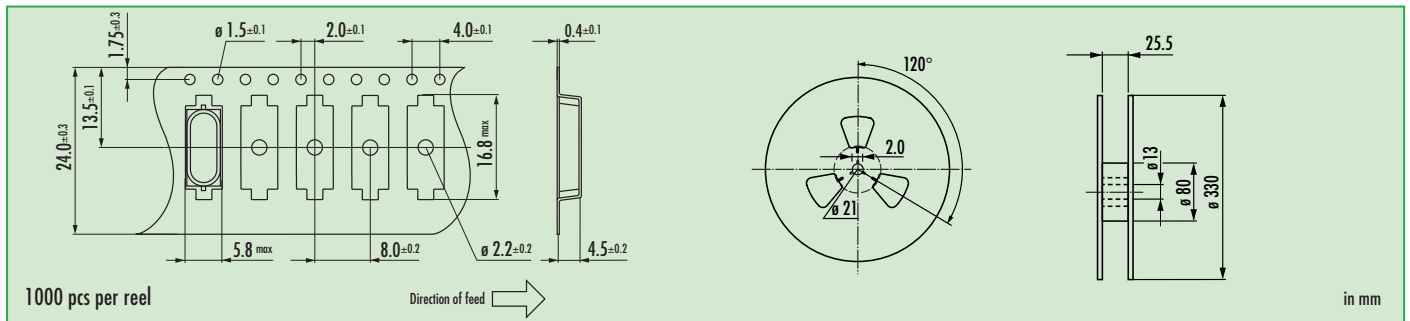

Reflow Soldering Profile

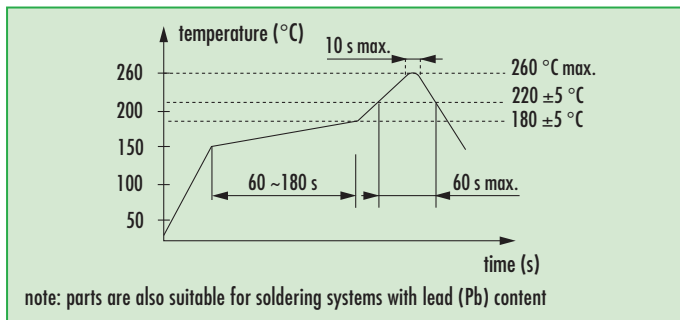

Load Capacitance Codes

7 pF: m	13 pF: v	20 pF: c	32 pF: e
8 pF: k	14 pF: x	22 pF: g	series: s
9 pF: n	15 pF: j	24 pF: d	T: 3rd OT
10 pF: h	16 pF: b	25 pF: r	
11 pF: l	17 pF: t	27 pF: w	
12 pF: a	18 pF: f	30 pF: .	

example 4.0 MHz / 12 pF: 4a000

Marking

frequency with load capacitance code
company code / date code / internal code

	Jan.	Feb.	Mar.	Apr.	May	Jun.	Jul.	Aug.	Sept.	Oct.	Nov.	Dec.
2011 2015	a	b	c	d	e	f	g	h	i	k	l	m
2012 2016	n	p	q	r	s	t	u	v	w	x	y	z
2013 2017	A	B	C	D	E	F	G	H	J	K	L	M
2014 2018	N	P	Q	R	S	T	U	V	W	X	Y	Z



B.C.E. s.r.l.
Via Regina Pacis, 54/c - 41049 SASSUOLO (MO) Italy
Tel. +39 0536 811.616 r.a. - Fax +39 0536 811.500
www.bce.it - E-mail: bce@bce.it



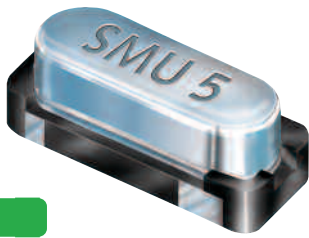

actual size

SMD Quartz Crystal · SMU5

4 Pad Version · 13.1 x 5.0 mm

- MG3A replacement type
- reflow soldering temperature: 260 °C max.
- package height 5 mm



General Data

type		SMU5
frequency range	fund. AT-cut	3.27680 ~ 33.0 MHz (> 33.0 MHz, ask if available)
	3rd OT AT-cut	ask for availability
	fund. BT-cut	ask for availability
frequency tolerance at 25 °C		± 20 ppm ~ ± 50 ppm / ± 50 ppm if ≤ 3.57 MHz
load capacitance C _L		12 pF ~ 32 pF or series / 30 pF standard
shunt capacitance C ₀		< 5 pF
storage temperature		-40 °C ~ +125 °C
drive level max.		500 µW (100 µW recommended)
aging		< ± 5 ppm first year

ESR (series resistance R_s)

frequency in MHz	vibration mode	ESR max. in Ω	ESR typ. in Ω
3.276 ~ 3.499	fund. AT	200	100
3.500 ~ 3.999	fund. AT	120	80
4.000 ~ 5.999	fund. AT	80	60
6.000 ~ 6.999	fund. AT	70	35
7.000 ~ 8.999	fund. AT	50	25
9.000 ~ 13.999	fund. AT	35	15
14.000 ~ 19.999	fund. AT	30	10
20.000 ~ 40.000	fund. AT	20	10
ask	3rd OT AT	(100)	(60)
ask	fund. BT	(50)	(20)

numbers in brackets () only for reference

Frequency Stability vs. Temperature

		± 20 ppm	± 30 ppm	± 50 ppm	± 100 ppm	± 150 ppm	+10/-100 ppm
-20 °C ~ +70 °C	STD	D	●	○			○ BT-cut
-40 °C ~ +85 °C	T1		○	● (*)	○		
-40 °C ~ +105 °C	T2			○	○		
-40 °C ~ +125 °C	T3				D	○	

● standard ○ available D ask, if available (*) if ≤ 3.57 MHz, not better than ± 100 ppm at temp. range T1

Marking

frequency with load capacitance code
company code / date code / internal code

	Jan.	Febr.	Mar.	Apr.	May	June	July	Aug.	Sept.	Okt.	Nov.	Dec.
2012	n	p	q	r	s	t	u	v	w	x	y	z
2013	A	B	C	D	E	F	G	H	J	K	L	M
2014	N	P	Q	R	S	T	U	V	W	X	Y	Z
2015	a	b	c	d	e	f	g	h	i	k	l	m

Dimensions

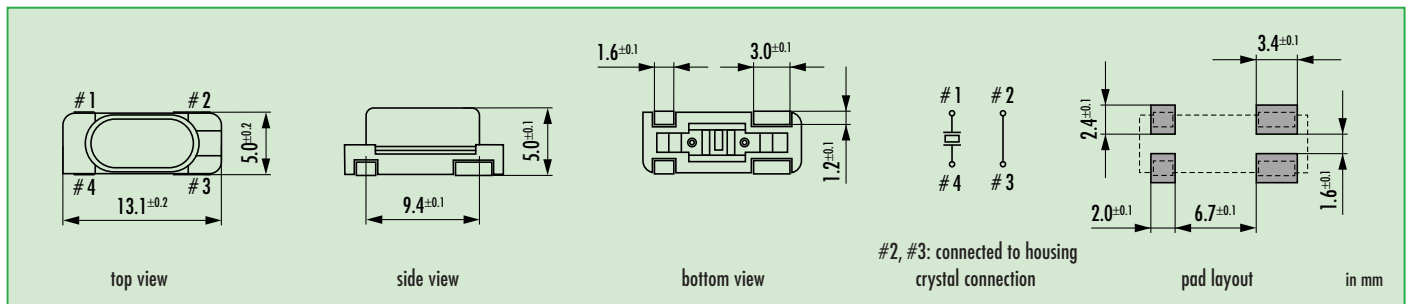

Order Information

Q	frequency	type	load capacitance	stability at 25 °C	stability vs. temp. range	option
Quartz	3.27680 ~ 33.0 MHz	SMU5	30 pF standard 12 pF ~ 32 pF S for series	30 ± 30 ppm std 20 ± 20 ppm 50 ± 50 ppm	see table	blank = -20 °C ~ +70 °C T1 = -40 °C ~ +85 °C T2 = -40 °C ~ +105 °C T3 = -40 °C ~ +125 °C FU = for fundamental frequencies ≥ 20 MHz 30T = 3rd overtone (if available) BT = fundamental BT-cut (if available)

Example: Q 30.0-SMU5-30-30/50-T1-FU-LF (Suffix LF = RoHS compliant / Pb free pins or pads)



SMD Quartz Crystal · SMU5

Taping Specification

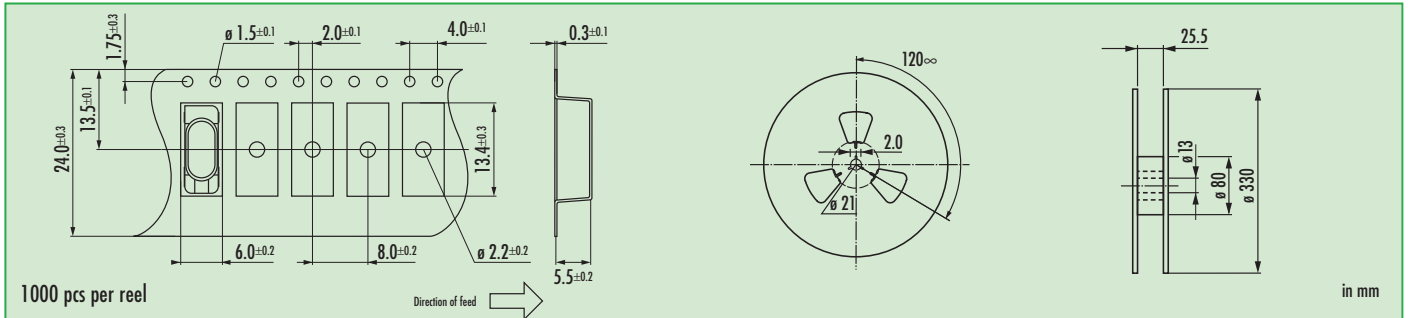

Reflow Soldering Profile

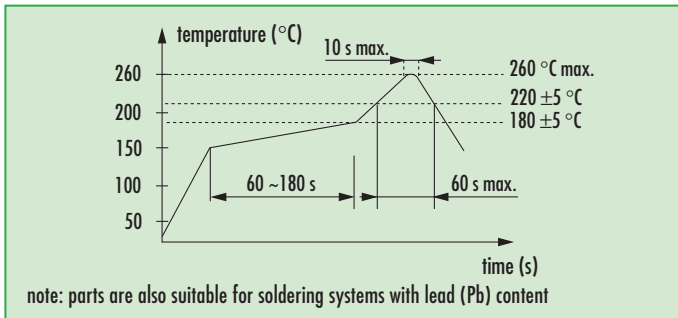

Load Capacitance Codes

7 pF: m	13 pF: v	20 pF: c	32 pF: e
8 pF: k	14 pF: x	22 pF: g	series: s
9 pF: n	15 pF: j	24 pF: d	T: 3rd OT
10 pF: h	16 pF: b	25 pF: r	
11 pF: l	17 pF: t	27 pF: w	
12 pF: a	18 pF: f	30 pF: .	

example 4.0 MHz / 12 pF: 4a000





actual size

SMD Quartz Crystal · MG3A

4 Pad Version · 13.1 x 5.0 mm

- automotive temperature range available
- reflow soldering temperature: 260 °C max.
- suitable for automotive applications



General Data

type	MG3A	
frequency range	3.50 ~ 40.0 MHz	(fund. AT-cut)
	30.0 ~ 48.0 MHz	(3rd OT. AT-cut)
	ask, if higher frequencies are available	
frequency tolerance at 25 °C	± 20 ppm ~ ± 50 ppm	
load capacitance C _L	12 pF ~ 32 pF or series	
shunt capacitance C ₀	< 5 pF	
storage temperature	-40 °C ~ +125 °C	
drive level max.	500 µW (100 µW recommended)	
aging	< ± 5 ppm first year	

ESR (series resistance Rs)

frequency in MHz	vibration mode	ESR max. in Ω	ESR typ. in Ω
3.50 ~ 3.6999	fund.- AT	180	70-100
3.70 ~ 4.0999	fund.- AT	150	50-80
4.10 ~ 5.9999	fund.- AT	120	40-60
6.00 ~ 9.9999	fund.- AT	80	20-40
10.0 ~ 13.999	fund.- AT	50	15-35
14.0 ~ 19.999	fund.- AT	35	10-15
20.0 ~ 40.000	fund.- AT	20	10-15
30.0 ~ 48.000	3rd OT- AT	100	80

Frequency Stability vs. Temperature

		± 30 ppm	± 50 ppm	± 100 ppm	± 150 ppm
-20 °C ~ +70 °C	STD.	○	●		
-40 °C ~ +85 °C	T1		○	●	
-40 °C ~ +105 °C	T2		○	○	
-40 °C ~ +125 °C	T3			○	○

● standard
○ available

Marking

frequency with load capacitance code
company code / date code / internal code

		Jan.	Febr.	Mar.	Apr.	May	June	July	Aug.	Sept.	Okt.	Nov.	Dec.
2011	2015	a	b	c	d	e	f	g	h	i	k	l	m
2012	2016	n	p	q	r	s	t	u	v	w	x	y	z
2013	2017	A	B	C	D	E	F	G	H	J	K	L	M
2014	2018	N	P	Q	R	S	T	U	V	W	X	Y	Z

Dimensions

pin connection
#1 - #4: X-tal
#2 - #3: GND

Order Information

Q	frequency	type	load capacitance	stability at 25 °C	stability vs. temp. range	option
Quartz	3.50 ~ 48.0 MHz	MG3A	30 pF standard 12 pF ~ 32 pF S for series	50 = ± 50 ppm std	see table	blank = -20 °C ~ +70 °C T1 = -40 °C ~ +85 °C T2 = -40 °C ~ +105 °C T3 = -40 °C ~ +125 °C FU = for fundamental frequencies ≥ 20 MHz 30T = 3rd overtone

Example: Q 30.0-MG3A-30-50/50-FU-LF (Suffix LF = RoHS compliant / Pb free pins or pads)



SMD Quartz Crystal · MG3A

Taping Specification

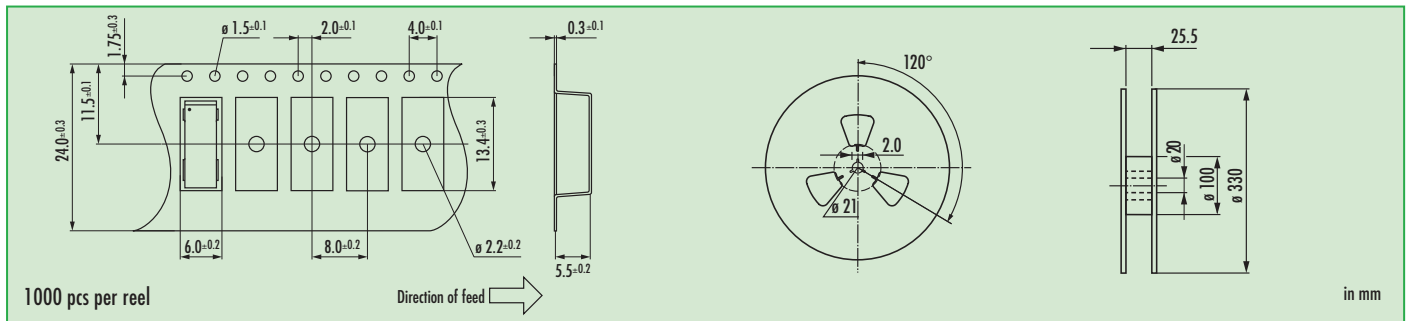

Reflow Soldering Profile

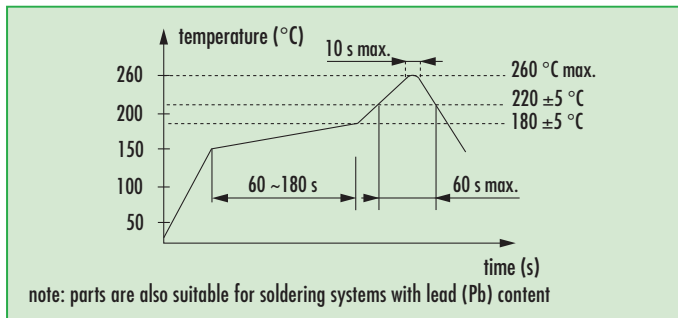

Load Capacitance Codes

7 pF: m	13 pF: v	20 pF: c	32 pF: e
8 pF: k	14 pF: x	22 pF: g	series: s
9 pF: n	15 pF: j	24 pF: d	T: 3rd OT
10 pF: h	16 pF: b	25 pF: r	
11 pF: l	17 pF: t	27 pF: w	
12 pF: a	18 pF: f	30 pF: .	

example 4.0 MHz / 12 pF: 4a000



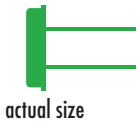
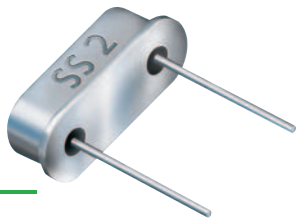

actual size

Quartz Crystal · SS2

Pin Type Crystal · 11.35 x 4.65 mm

- recommended for automotive applications
- wave soldering temperature: 260 °C max.
- package height 2.5 mm max.



General Data

type	SS2	
frequency range	fund. AT-cut	4.0 ~ 33.0 MHz
	3rd OT AT-cut	ask for availability
	fund. BT-cut	ask for availability
frequency tolerance at 25 °C	± 20 ppm / ± 30 ppm / ± 50 ppm	
load capacitance C_L	12 pF ~ 32 pF or series	
shunt capacitance C_0	< 5 pF	
storage temperature	-40 °C ~ +125 °C	
shock resistance	> 100 g (half sine pulse, 0.6 ms)	
drive level max.	500 µW (100 µW recommended)	
aging	< ± 5 ppm first year	

Dimensions

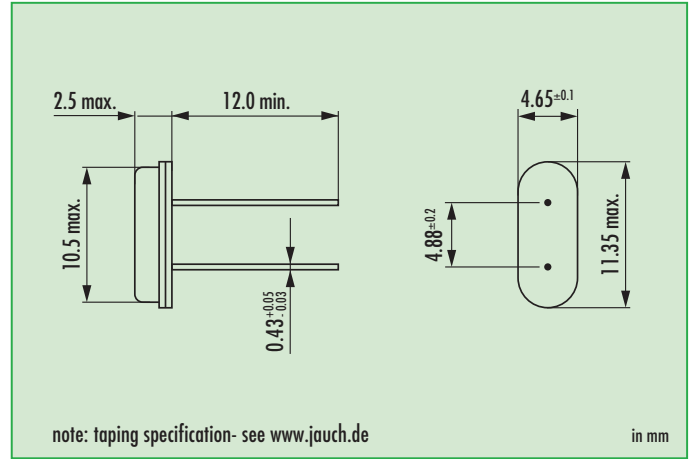

Frequency Stability vs. Temperature

		± 20 ppm	± 30 ppm	± 50 ppm	± 100 ppm	± 150 ppm	+10/-100 ppm
-20 °C ~ +70 °C	STD	D	○	●			○ BT-cut
-40 °C ~ +85 °C	T1		○	○	●		
-40 °C ~ +105 °C	T2			○	○		
-40 °C ~ +125 °C	T3					○	

● standard
○ available
D ask, if available

ESR (series resistance R_s)

frequency in MHz	vibration mode	ESR max. in Ω	ESR typ. in Ω
4.0 ~ 5.999	fund. AT	80	60
6.0 ~ 6.999	fund. AT	70	35
7.0 ~ 7.999	fund. AT	50	25
8.0 ~ 8.999	fund. AT	50	25
9.0 ~ 13.999	fund. AT	35	15
14.0 ~ 33.000	fund. AT	30	10
ask	3rd OT AT	(100)	(60)
ask	fund. BT	(50)	(20)

Automotive application note

- automotive quartz crystals have superior environmental performance in case of shock, vibration and temperature
- extended operating temperatures up to +125 °C
- production is certified according to: ISO 9001 / TS 16949 / ISO 14001

Order Information

Q	frequency	type	load capacitance in pF	stability at 25 °C	stability vs. temp. range	option
Quartz	4.0 ~ 33.0 MHz	SS2	12 pF ~ 32 pF S for series	30 = ± 30 ppm std 20 = ± 20 ppm 50 = ± 50 ppm	see table	blank = -20 °C ~ +70 °C T1 = -40 °C ~ +85 °C T2 = -40 °C ~ +105 °C T3 = -40 °C ~ +125 °C FU = for fundamental frequencies ≥ 20 MHz 30T = 3rd overtone (if available) BT = fundamental BT-cut (if available) TR = taped TA = taped, ammo pack KIS = insulation spacer LL = lead length in mm PT = plastic tray

Example: Q 30.0-SS2-30-30/50-FU-LF (Suffix LF = RoHS compliant / Pb free pins or pads)



Quartz Crystal · SS2 · Automotive Applications

Load Capacitance Codes

12 pF: a	18 pF: f	30 pF: .
13 pF: v	20 pF: c	32 pF: e
14 pF: x	22 pF: g	series: s
15 pF: j	24 pF: d	T: 3rd OT
16 pF: b	25 pF: r	
17 pF: t	27 pF: w	

example 4.0 MHz / 12 pF: 4a000

Wave Soldering Profile

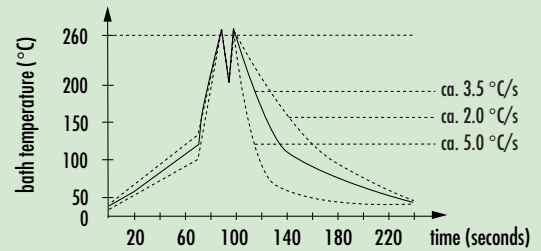

Taping Specification

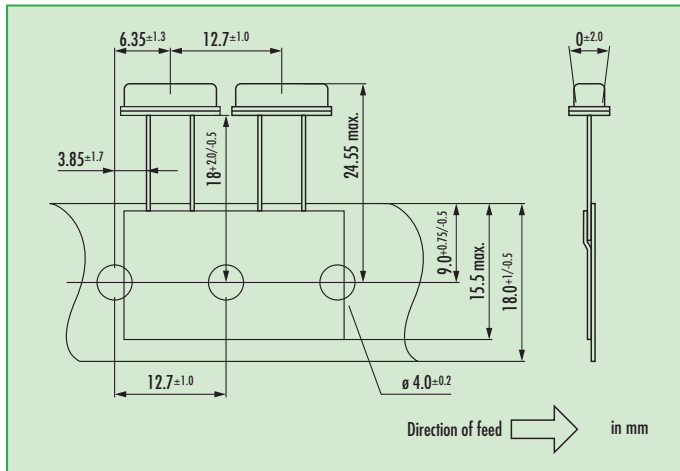

Marking

frequency with load capacitance code
company code / date code / internal code

		Jan.	Feb.	Mar.	Apr.	May	Jun.	Jul.	Aug.	Sept.	Oct.	Nov.	Dec.
2011	2015	a	b	c	d	e	f	g	h	j	k	l	m
2012	2016	n	p	q	r	s	t	u	v	w	x	y	z
2013	2017	A	B	C	D	E	F	G	H	J	K	L	M
2014	2018	N	P	Q	R	S	T	U	V	W	X	Y	Z



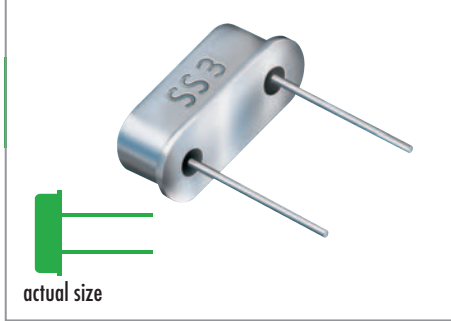

Quartz Crystal · SS3

Pin Type Crystal · 11.35 x 4.65 mm

- recommended for automotive applications
- wave soldering temperature: 260 °C max.
- package height 3.6 mm max.



General Data

type	SS3	
frequency range	fund. AT-cut	3.27680 ~ 33.0 MHz
	3rd OT AT-cut	ask for availability
	fund. BT-cut	ask for availability
frequency tolerance at 25 °C	± 20 ppm ~ ± 50 ppm / ± 50 ppm if ≤ 3.57 MHz	
load capacitance C_L	12 pF ~ 32 pF or series / 30 pF standard	
shunt capacitance C_0	< 5 pF	
storage temperature	-40 °C ~ +125 °C	
shock resistance	> 100 g (half sine pulse, 0.6 ms)	
drive level max.	500 µW (100 µW recommended)	
aging	< ± 5 ppm first year	

Dimensions

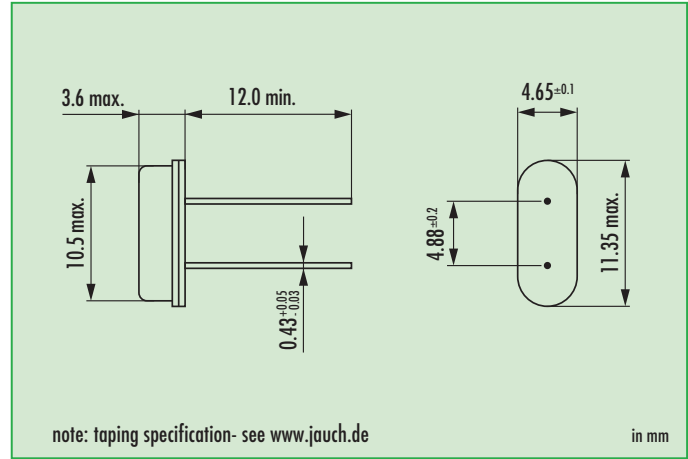

Frequency Stability vs. Temperature

		± 20 ppm	± 30 ppm	± 50 ppm	± 100 ppm	± 150 ppm	+10/-100 ppm
-20 °C ~ +70 °C	STD	D	○	●			○ BT-cut
-40 °C ~ +85 °C	T1		○	● (*)	○		
-40 °C ~ +105 °C	T2			○	○		
-40 °C ~ +125 °C	T3					○	

● standard (*) if ≤ 3.57 MHz, not better than ± 100 ppm at temp. range T1
○ available
D ask, if available

ESR (series resistance R_s)

frequency in MHz	vibration mode	ESR max. in Ω	ESR typ. in Ω
3.276 ~ 3.499	fund. AT	200	100
3.500 ~ 3.999	fund. AT	120	80
4.000 ~ 5.999	fund. AT	80	60
6.000 ~ 6.999	fund. AT	70	35
7.000 ~ 8.999	fund. AT	50	25
9.000 ~ 13.999	fund. AT	35	15
14.000 ~ 33.000	fund. AT	30	10
ask	3rd OT AT	(100)	(60)
ask	fund. BT	(50)	(20)

numbers in brackets () only for reference

Automotive application note

- automotive quartz crystals have superior environmental performance in case of shock, vibration and temperature
- extended operating temperatures up to +125 °C
- production is certified according to: ISO 9001 / TS 16949 / ISO 14001

Order Information

Q	frequency	type	load capacitance in pF	stability at 25 °C	stability vs. temp. range	option
Quartz	3.27680 ~ 33.0 MHz	SS3	12 pF ~ 32 pF S for series 30 pF standard	30 = ± 30 ppm std 20 = ± 20 ppm 50 = ± 50 ppm	see table	blank = -20 °C ~ +70 °C T1 = -40 °C ~ +85 °C T2 = -40 °C ~ +105 °C T3 = -40 °C ~ +125 °C FU = for fundamental frequencies ≥ 20 MHz 30T = 3rd overtone (if available) BT = fundamental BT-cut (if available) MP = middle pin TR = taped TA = taped, ammo pack KIS = insulation spacer LL = lead length in mm PT = plastic tray

Example: Q 30.0-SS3-30-30/50-FU-LF (Suffix LF = RoHS compliant / Pb free pins or pads)



Quartz Crystal · SS3 · Automotive Applications

Load Capacitance Codes

12 pF: a	18 pF: f	30 pF: .
13 pF: v	20 pF: c	32 pF: e
14 pF: x	22 pF: g	series: s
15 pF: j	24 pF: d	T: 3rd OT
16 pF: b	25 pF: r	
17 pF: t	27 pF: w	

example 4.0 MHz / 12 pF: 4a000

Wave Soldering Profile

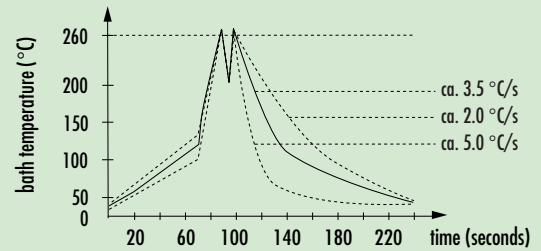

Taping Specification

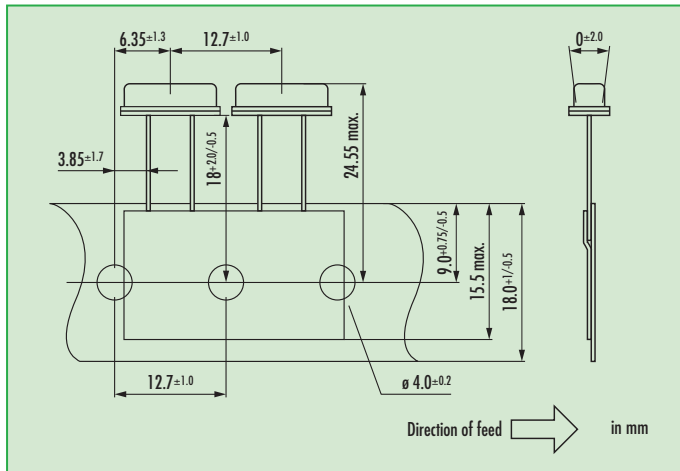

Marking

frequency with load capacitance code
company code / date code / internal code

		Jan.	Feb.	Mar.	Apr.	May	Jun.	Jul.	Aug.	Sept.	Oct.	Nov.	Dec.
2011	2015	a	b	c	d	e	f	g	h	j	k	l	m
2012	2016	n	p	q	r	s	t	u	v	w	x	y	z
2013	2017	A	B	C	D	E	F	G	H	J	K	L	M
2014	2018	N	P	Q	R	S	T	U	V	W	X	Y	Z



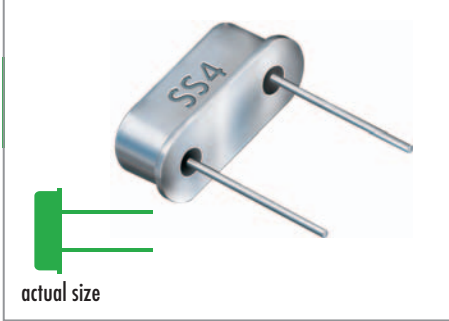

Quartz Crystal · SS4

Pin Type Crystal · 11.35 x 4.65 mm

- taped version available
- wave soldering temperature: 260 °C max.
- package height 3.6 mm max.



General Data

type	SS4	
frequency range	fund. AT-cut	3.27680 ~ 33.0 MHz (> 33.0 MHz, ask if available)
	3rd OT AT-cut	ask for availability
	fund. BT-cut	ask for availability
frequency tolerance at 25 °C	± 20 ppm ~ ± 50 ppm / ± 50 ppm if ≤ 3.57 MHz	
load capacitance C_L	12 pF ~ 32 pF or series / 30 pF standard	
shunt capacitance C₀	< 5 pF	
storage temperature	-40 °C ~ +125 °C	
drive level max.	500 µW (100 µW recommended)	
aging	< ± 5 ppm first year	

Dimensions

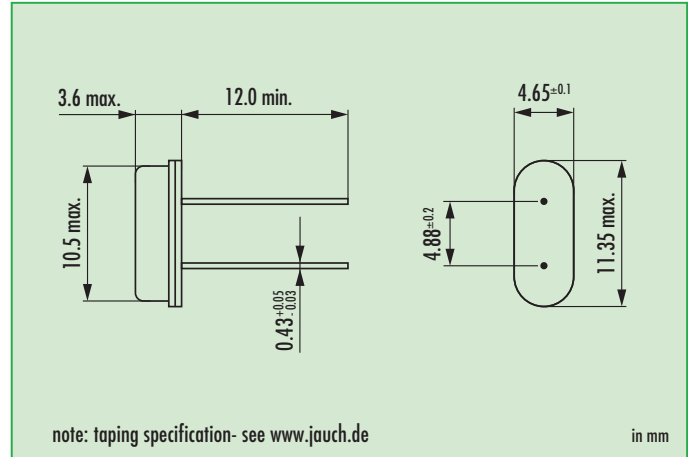

Frequency Stability vs. Temperature

		± 20 ppm	± 30 ppm	± 50 ppm	± 100 ppm	± 150 ppm	+10/-100 ppm
-20 °C ~ +70 °C	STD	D	●	●			○ BT-cut
-40 °C ~ +85 °C	T1		○	○(*)	●		

● standard (°) if ≤ 3.57 MHz, not better than ± 100 ppm at temp. range T1
 ○ available
 D ask, if available

ESR (series resistance R_s)

frequency in MHz	vibration mode	ESR max. in Ω	ESR typ. in Ω
3.276 ~ 3.499	fund. AT	200	100
3.500 ~ 3.999	fund. AT	120	80
4.000 ~ 5.999	fund. AT	80	60
6.000 ~ 6.999	fund. AT	70	35
7.000 ~ 8.999	fund. AT	50	25
9.000 ~ 13.999	fund. AT	35	15
14.000 ~ 33.000	fund. AT	30	10
(33.000 ~ 40.000)	fund. AT	(30)	(10)
ask	3rd OT AT	(100)	(60)
ask	fund. BT	(50)	(20)

numbers in brackets () only for reference

Order Information

Q	frequency	type	load capacitance in pF	stability at 25 °C	stability vs. temp. range	option
Quartz	3.27680 ~ 33.0 MHz	SS4	12 pF ~ 32 pF S for series 30 pF standard	30 = ± 30 ppm std 20 = ± 20 ppm 50 = ± 50 ppm	see table	blank = -20 °C ~ +70 °C T1 = -40 °C ~ +85 °C FU = for fundamental frequencies ≥ 20 MHz 30T = 3rd overtone (if available) BT = fundamental BT-cut (if available) MP = middle pin TR = taped TA = taped, ammo pack KIS = insulation spacer LL = lead length in mm PT = plastic tray

Example: Q 30.0-SS4-30-30/50-T1-FU-LF (Suffix LF = RoHS compliant / Pb free pins or pads)



Quartz Crystal · SS4

Load Capacitance Codes

12 pF: a	18 pF: f	30 pF: .
13 pF: v	20 pF: c	32 pF: e
14 pF: x	22 pF: g	series: s
15 pF: j	24 pF: d	T: 3rd OT
16 pF: b	25 pF: r	
17 pF: t	27 pF: w	

example 4.0 MHz / 12 pF: 4a000

Wave Soldering Profile

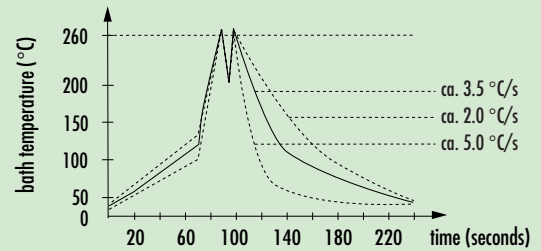

Taping Specification

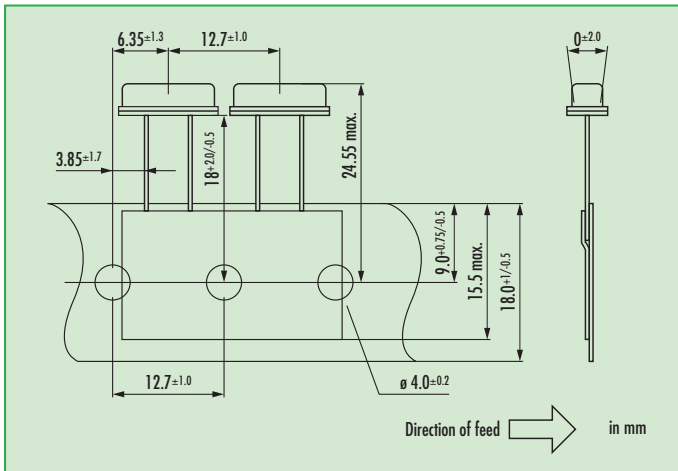

Marking

frequency with load capacitance code
company code / date code / internal code

		Jan.	Feb.	Mar.	Apr.	May	Jun.	Jul.	Aug.	Sept.	Oct.	Nov.	Dec.
2011	2015	a	b	c	d	e	f	g	h	j	k	l	m
2012	2016	n	p	q	r	s	t	u	v	w	x	y	z
2013	2017	A	B	C	D	E	F	G	H	J	K	L	M
2014	2018	N	P	Q	R	S	T	U	V	W	X	Y	Z



B.C.E. s.r.l.
Via Regina Pacis, 54/c - 41049 SASSUOLO (MO) Italy
Tel. +39 0536 811.616 r.a. - Fax +39 0536 811.500
www.bce.it - E-mail: bce@bce.it



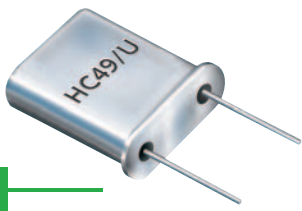

actual size

Quartz Crystal · HC49/U

Pin Type Crystal · 10.8 x 4.5 mm

- available for developed frequencies only
- not preferable for new design-in
- wave soldering temperature: 260 °C max.



General Data

type	S (HC49/U)
frequency range	0.92160 / 1.000 MHz* (fund. SL-cut) 1.8432 ~ 40.0 MHz (fund. AT-cut) 20.0 ~ 105.0 MHz (3rd OT AT-cut) 50.0 ~ 175.0 MHz (5th OT AT-cut) 70.0 ~ 250.0 MHz (7th OT AT-cut)
frequency tolerance at 25 °C	± 3 ppm ~ ± 50 ppm
load capacitance C _L	8 pF ~ 32 pF or series
shunt capacitance C ₀	< 7 pF
storage temperature	-55 °C ~ +125 °C
drive level max.	1.0 mW
aging	< ± 5 ppm first year

* other frequency upon request

Frequency Stability vs. Temperature

		± 3 ppm	± 5 ppm	± 10 ppm	± 30 ppm	± 50 ppm	± 100 ppm
0 °C ~ +60 °C		○	○	○			
-20 °C ~ +70 °C	STD.		○	○	●		
-40 °C ~ +85 °C	T1			○	○	●	
-40 °C ~ +90 °C	T4				○	○	○
-40 °C ~ +105 °C	T2				○	○	○
-40 °C ~ +125 °C	T3					○	○
-10 °C ~ +60 °C	SL-cut						○
-20 °C ~ +70 °C	SL-cut						○

- standard
- available

Dimensions

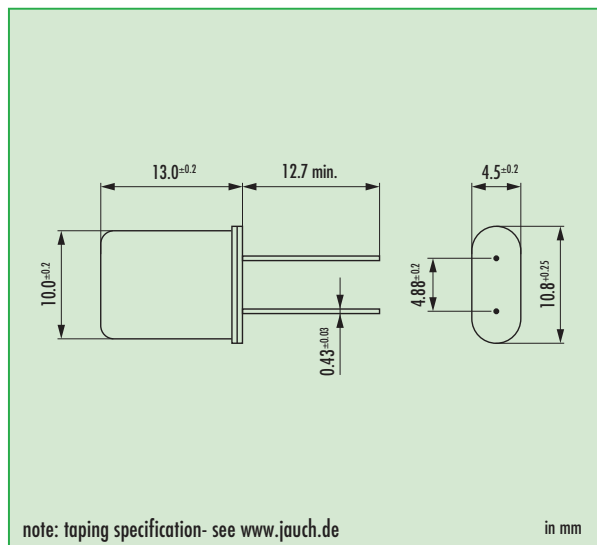

note: taping specification- see www.jauch.de

in mm

ESR (series resistance Rs)

frequency in MHz	vibration mode	ESR max. in Ω	ESR typ. in Ω
0.92 / 1.000	fund.- SL	3000	800
1.8432	fund.- AT	800	400
2.00 ~ 2.999	fund.- AT	400	150
3.00 ~ 3.4999	fund.- AT	150	50
3.57 ~ 6.9999	fund.- AT	60	20
7.00 ~ 12.999	fund.- AT	30	15
13.0 ~ 40.000	fund.- AT	20	10
20.0 ~ 29.999	3rd OT - AT	80	35
30.0 ~ 105.00	3rd OT - AT	60	30
50.0 ~ 175.00	5th OT - AT	150	60
70.0 ~ 250.00	7th OT - AT	180	80

Marking

frequency
company code / load capacitance
data code / internal code

Option Table

TP = top pin
MP = middle pin
TR = taped
TA = taped, ammo pack
KIS = spacer
IS = insulation spacer
LL = lead length in mm
PT = plastic tray

Order Information

Q	frequency	type	load capacitance in pF	tolerance at 25 °C	stability vs. temp. range	option
Quartz	0.9216 ~ 250.0 MHz	S	30 pF standard 12 pF ~ 32 pF S for series	± 30 ppm std. > 1.8 MHz ± 3 ppm ~ ± 50 ppm on requ. ± 50 ppm for SL-cut	> 3.5 MHz: stability see table, on request < 3.5 MHz: ± 50 ppm for SL-cut: ± 100 ppm	blank = -20 °C ~ +70 °C T1 = -40 °C ~ +85 °C T2 = -40 °C ~ +105 °C T3 = -40 °C ~ +125 °C T4 = -40 °C ~ +90 °C FU = for fund. frequ. ≥ 20 MHz 30T = 3rd overtone 50T = 5th overtone 70T = 7th overtone

Example: Q 28.0-S-30-30/30-FU (Suffix LF = RoHS compliant / Pb free pins) other see option table



Quartz Crystal · HC49/U

Taping Specification Through Hole Version

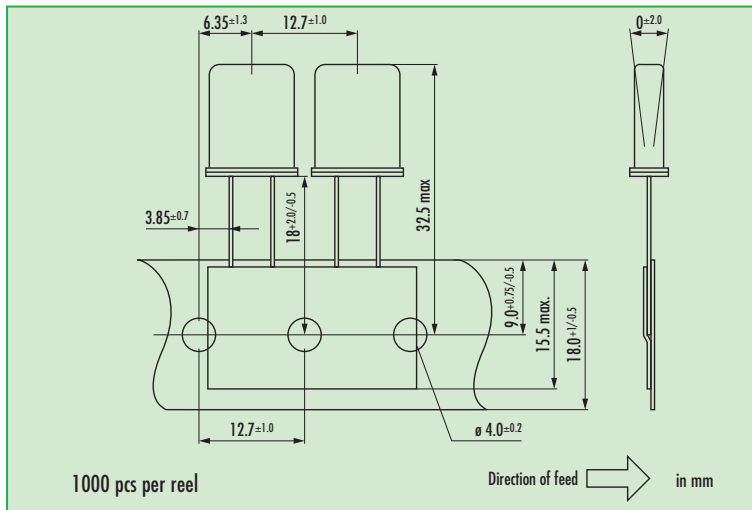

Wave Soldering Profile

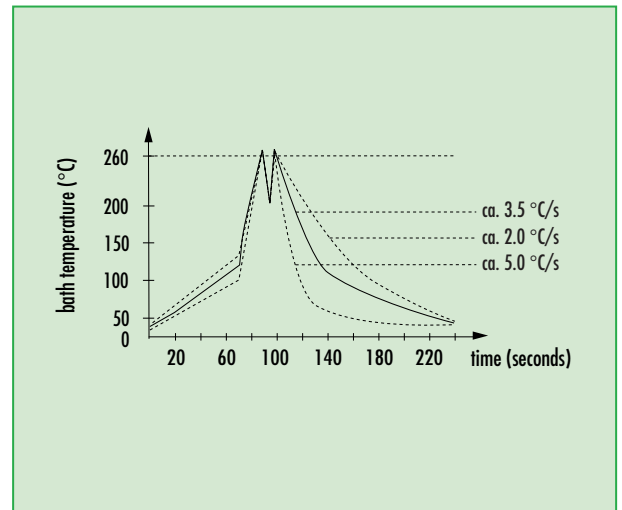



actual size

Quartz Crystal · HC49/U-SMC

SMD Crystal Version · 17.5 x 10.8 mm

- available for developed frequencies only
- SMD version
- reflow soldering temperature: 260 °C max.



General Data

type	S (HC49/U-SMC)
frequency range	0.92160 / 1.000 MHz (fund. SL-cut)
	1.8432 ~ 40.0 MHz (fund. AT-cut)
	20.0 ~ 105.0 MHz (3rd OT AT-cut)
	50.0 ~ 175.0 MHz (5th OT AT-cut)
	70.0 ~ 250.0 MHz (7th OT AT-cut)
frequency tolerance at 25 °C	± 3 ppm ~ ± 50 ppm
load capacitance C_L	8 pF ~ 32 pF or series
shunt capacitance C_0	< 7 pF
storage temperature	-55 °C ~ +125 °C
drive level max.	1.0 mW
aging	< ± 5 ppm first year

Dimensions

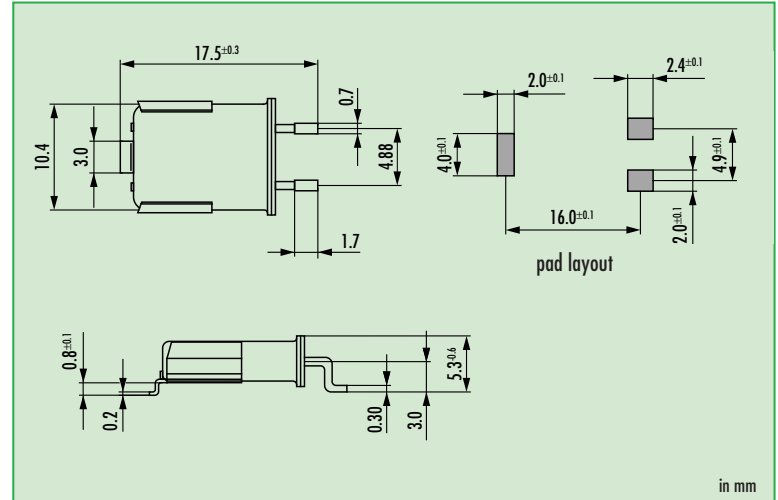

Frequency Stability vs. Temperature

		± 3 ppm	± 5 ppm	± 10 ppm	± 30 ppm	± 50 ppm	± 100 ppm
0 °C ~ +60 °C		○	○	○			
-20 °C ~ +70 °C	STD.		○	○	●		
-40 °C ~ +85 °C	T1			○	○	●	
-40 °C ~ +90 °C	T4				○	○	○
-40 °C ~ +105 °C	T2				○	○	○
-40 °C ~ +125 °C	T3						○

● standard
○ available

ESR (series resistance R_s)

frequency in MHz	vibration mode	ESR max. in Ω	ESR typ. in Ω
0.92 / 1.000	fund.- SL	3000	800
1.8432	fund.- AT	800	400
2.00 ~ 2.999	fund.- AT	400	200
3.00 ~ 3.4999	fund.- AT	150	50
3.57 ~ 6.9999	fund.- AT	60	20
7.00 ~ 12.999	fund.- AT	30	15
13.0 ~ 40.000	fund.- AT	20	10
20.0 ~ 105.00	3rd OT - AT	80	35
50.0 ~ 175.00	5th OT - AT	150	70

Order Information

Q	frequency	type	load capacitance in pF	stability at 25 °C	stability vs. temp. range	option	SMD version
Quartz	0.9216 ~ 250.0 MHz	S	30 pF standard 12 pF ~ 32 pF S for series	± 3 ppm ~ ± 50 ppm see table	± 100 ppm SL-cut other see table	blank = -20 °C ~ +70 °C T1 = -40 °C ~ +85 °C T2 = -40 °C ~ +105 °C T3 = -40 °C ~ +125 °C T4 = -40 °C ~ +90 °C FU = for fundamental frequencies ≥ 20 MHz 3OT = 3rd overtone 5OT = 5th overtone 7OT = 7th overtone	SMC

Example: Q 28.0-S-30-30/30-T1-FU-SMC-LF (Suffix LF = RoHS compliant / Pb free pins)



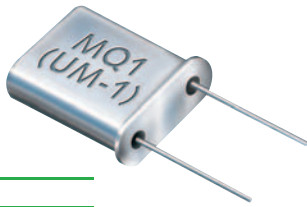

actual size

Quartz Crystal · MQ1 (UM-1)

Pin Type Crystal · 7.9 x 3.3 mm

- high frequency stability
- wave soldering temperature: 260 °C max.
- package height 8.0 mm max.



General Data

type	MQ1 (UM-1)
frequency range	0.9216 / 1.0 MHz* (fund. SL-cut)
	4.00 ~ 40.00 MHz (fund. AT-cut)
	20.0 ~ 105.0 MHz (3rd OT AT-cut)
	50.0 ~ 175.0 MHz (5th OT AT-cut)
	70.0 ~ 250.0 MHz (7th OT AT-cut)
frequency tolerance at 25 °C	± 5 ppm ~ ± 30 ppm
load capacitance C_L	8 pF ~ 32 pF or series
shunt capacitance C_0	< 7 pF
storage temperature	-55 °C ~ +125 °C
drive level max.	500 µW (100 µW recommended)
aging	< ± 3 ppm first year

* other frequencies upon request

Dimensions

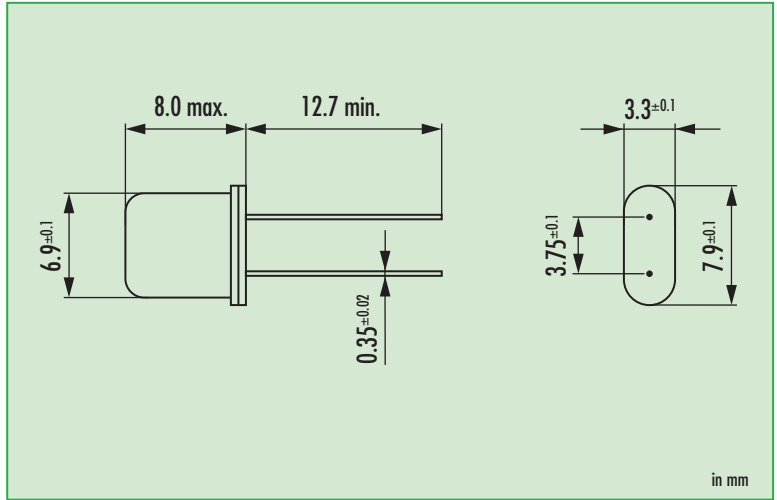

Frequency Stability vs. Temperature

		± 3 ppm	± 5 ppm	± 10 ppm	± 30 ppm	± 50 ppm	± 100 ppm
0 °C ~ +60 °C		○	○	○			
-20 °C ~ +70 °C	STD.		○	○	●		
-40 °C ~ +85 °C	T1			○	○	●	
-40 °C ~ +90 °C	T4				○	○	○
-40 °C ~ +105 °C	T2				○	○	○
-40 °C ~ +125 °C	T3					○	○
-10 °C ~ +60 °C	SL						○
-20 °C ~ +70 °C	SL						○

● standard
○ available

ESR (series resistance R_s)

frequency in MHz	vibration mode	ESR max. in Ω	ESR typ. in Ω
0.92 / 1.000	fund.- SL	3000	800
4.00 ~ 4.9999	fund.- AT	150	80
5.00 ~ 9.9999	fund.- AT	80	40
10.0 ~ 14.999	fund.- AT	40	20
15.0 ~ 40.000	fund.- AT	30	15
20.0 ~ 49.999	3rd OT - AT	80	40
50.0 ~ 105.00	3rd OT - AT	60	30
50.0 ~ 175.00	5th OT - AT	150	80
70.0 ~ 119.99	7th OT - AT	200	150
120.0 ~ 250.0	7th OT - AT	180	120

Order Information

Q	frequency	type	load capacitance in pF	stability at 25 °C	stability vs. temp. range	option
Quartz	0.9216 ~ 250.0 MHz	MQ1	8 pF ~ 32 pF S for series	± 5 ~ ± 30 ppm ± 50 ppm for SL-cut ± 30 ppm std.	± 100 ppm for SL-cut	blank = -20 °C ~ + 70 °C T1 = -40 °C ~ + 85 °C T2 = -40 °C ~ +105 °C T3 = -40 °C ~ +125 °C T4 = -40 °C ~ + 90 °C FU = for fundamental frequencies ≥ 20 MHz 30T = 3rd overtone 50T = 5th overtone 70T = 7th overtone MP = middle pin LL = lead length in mm PT = plastic tray

Example: Q 30.0-MQ1-30-30/50-FU (Suffix LF = RoHS compliant / Pb free pins or pads)



Quartz Crystal · MQ1 (UM-1)

Wave Soldering Profile

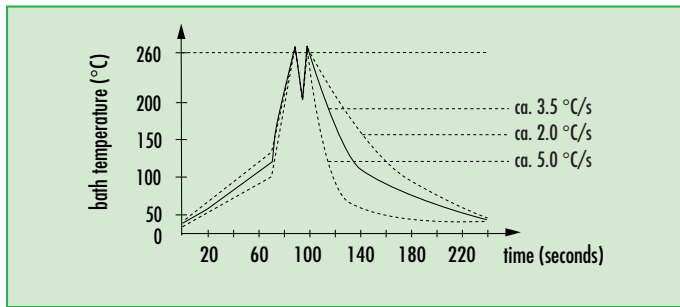

Marking

frequency
company code / date code





actual size

Quartz Crystal · MQ1-SMC

SMD Crystal Version · 11.7 x 7.8 mm

- automotive temperature range available
- reflow soldering temperature: 260 °C max.
- package height 3.6 mm max.



General Data

type	MQ1 (UM-1-SMC)
frequency range	0.9216 / 1.0 MHz (fund. SL-cut)
	4.00 ~ 40.00 MHz (fund. AT-cut)
	20.0 ~ 105.0 MHz (3rd OT AT-cut)
	50.0 ~ 175.0 MHz (5th OT AT-cut)
	70.0 ~ 250.0 MHz (7th OT AT-cut)
frequency tolerance at 25 °C	± 5 ppm ~ ± 30 ppm
load capacitance C_L	12 pF ~ 32 pF or series
shunt capacitance C_0	< 7 pF
storage temperature	-55 °C ~ +125 °C
drive level max.	500 µW (100 µW recommended)
aging	< ± 3 ppm first year

Dimensions

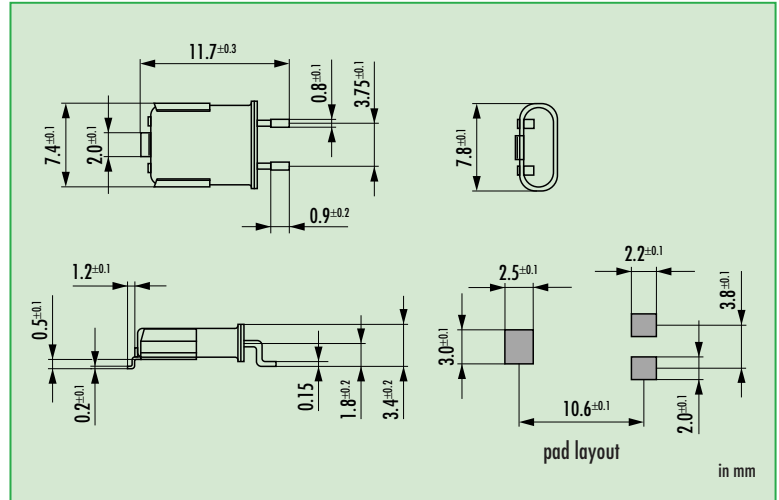

Frequency Stability vs. Temperature

		± 3 ppm	± 5 ppm	± 10 ppm	± 30 ppm	± 50 ppm	± 100 ppm
0 °C ~ +60 °C		○	○	○			
-20 °C ~ +70 °C	STD.		○	○	●		
-40 °C ~ +85 °C	T1			○	○	●	
-40 °C ~ +90 °C	T4				○	○	○
-40 °C ~ +105 °C	T2				○	○	○
-40 °C ~ +125 °C	T3						○

● standard
○ available

ESR (series resistance R_s)

frequency in MHz	vibration mode	ESR max. in Ω	ESR typ. in Ω
0.92 / 1.000	fund.- SL	3000	800
4.00 ~ 4.9999	fund.- AT	150	80
5.00 ~ 9.9999	fund.- AT	80	40
10.0 ~ 14.999	fund.- AT	40	20
15.0 ~ 40.000	fund.- AT	30	15
20.0 ~ 49.999	3rd OT- AT	80	70
50.0 ~ 105.00	3rd OT- AT	60	50
50.0 ~ 175.00	5th OT- AT	150	100
70.0 ~ 250.00	7th OT- AT	100	80

Order Information

Q	frequency	type	load capacitance in pF	stability at 25 °C	stability vs. temp. range	option	SMD version
Quartz	0.9216 ~ 250.0 MHz	MQ1	12 pF ~ 32 pF S for series	± 5 ~ ± 30 ppm	see table	blank = -20 °C ~ + 70 °C T1 = -40 °C ~ + 85 °C T2 = -40 °C ~ +105 °C T3 = -40 °C ~ +125 °C T4 = -40 °C ~ + 90 °C FU = for fundamental frequencies ≥ 20 MHz 3OT = 3rd overtone 5OT = 5th overtone 7OT = 7th overtone	SMC

Example: Q 30.0-MQ1-30-30/50-T1-FU-SMC-LF (Suffix LF = RoHS compliant / Pb free pins or pads)



Quartz Crystal · MQ1-SMC

Taping Specification

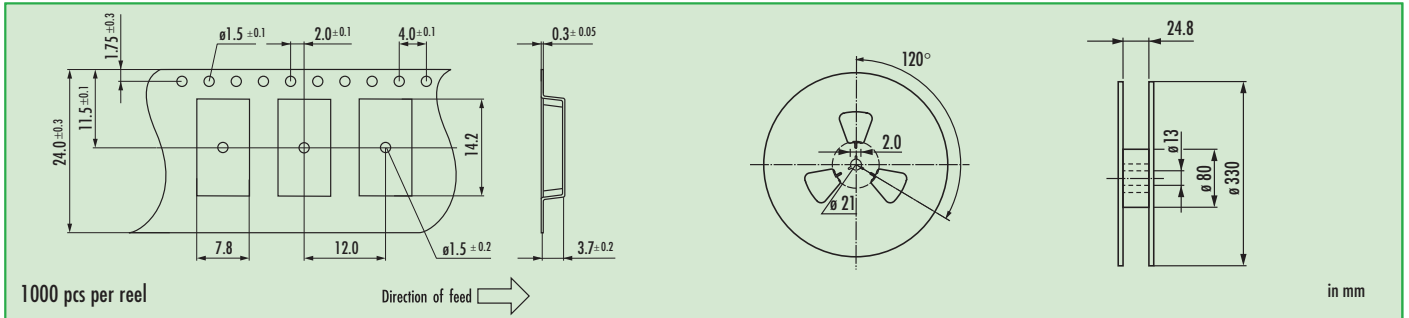

Reflow Soldering Profile

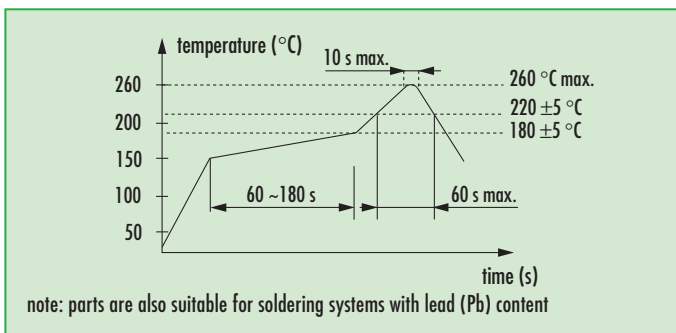

Marking

frequency
company code / date code



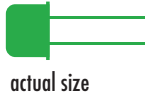
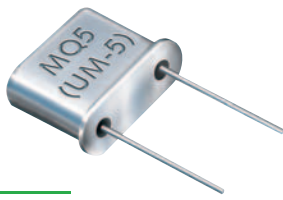

actual size

Quartz Crystal · MQ5 (UM-5)

Pin Type Crystal · 7.7 x 3.1 mm

- high frequency stability
- wave soldering temperature: 260 °C max.
- package height 6.0 mm max.



General Data

type	MQ5 (UM-5)	
frequency range	10.0 ~ 40.0 MHz	(fund. AT-cut)
	30.0 ~ 105.0 MHz	(3rd OT AT-cut)
	50.0 ~ 175.0 MHz	(5th OT AT-cut)
	70.0 ~ 250.0 MHz	(7th OT AT-cut)
frequency tolerance at 25 °C	± 5 ppm ~ ± 30 ppm	
load capacitance C_L	8 pF ~ 32 pF or series	
shunt capacitance C_0	< 7 pF	
storage temperature	-55 °C ~ +125 °C	
drive level max.	500 µW (100 µW recommended)	
aging	< ± 3 ppm first year	

Dimensions

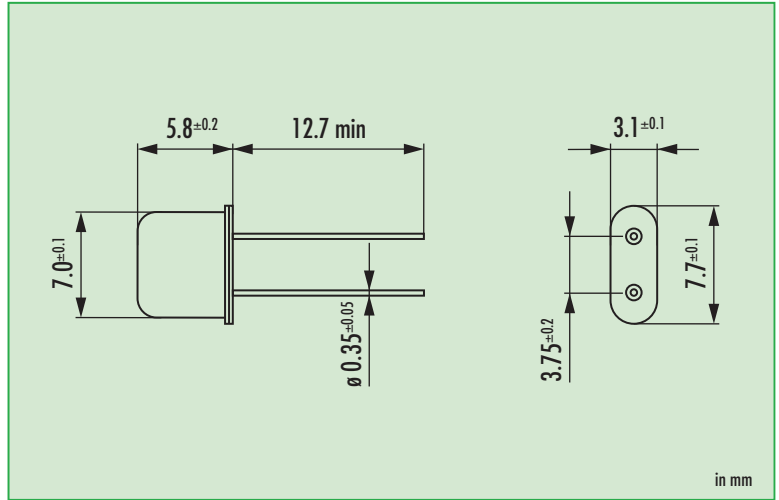

Frequency Stability vs. Temperature

		± 3 ppm	± 5 ppm	± 10 ppm	± 30 ppm	± 50 ppm	± 100 ppm
0 °C ~ +60 °C		○	○	○			
-20 °C ~ +70 °C	STD.		○	○	●		
-40 °C ~ +85 °C	T1			○*	○	●	
-40 °C ~ +90 °C	T4				○	○	○
-40 °C ~ +105 °C	T2				○	○	○
-40 °C ~ +125 °C	T3						○

● standard
○ available

* ± 15 ppm, for $f \leq 17$ MHz

ESR (series resistance R_s)

frequency in MHz	vibration mode	ESR max. in Ω	ESR typ. in Ω
10.0 ~ 19.999	fund.- AT	60	40
20.0 ~ 40.000	fund.- AT	40	20
30.0 ~ 79.999	3rd OT - AT	100	50
80.0 ~ 105.000	3rd OT - AT	80	40
50.0 ~ 59.999	5th OT - AT	250	150
60.0 ~ 129.99	5th OT - AT	200	100
130.0 ~ 175.0	5th OT - AT	180	120
70.0 ~ 129.99	7th OT - AT	250	180
130.0 ~ 250.0	7th OT - AT	200	150

Order Information

Q	frequency	type	load capacitance in pF	stability at 25 °C	stability vs. temp. range	option
Quartz	10.0 ~ 250.0 MHz	MQ5	8 pF ~ 32 pF S for series	± 5 ~ ± 30 ppm	see table	blank = -20 °C ~ + 70 °C T1 = -40 °C ~ + 85 °C T2 = -40 °C ~ +105 °C T3 = -40 °C ~ +125 °C T4 = -40 °C ~ + 90 °C FU = for fundamental frequencies ≥ 20 MHz 30T = 3rd overtone 50T = 5th overtone 70T = 7th overtone LL = lead length in mm PT = plastic tray

Example: Q 30.0-MQ5-30-5/30-FU (Suffix LF = RoHS compliant / Pb free pins or pads)



Quartz Crystal · MQ5 (UM-5)

Wave Soldering Profile

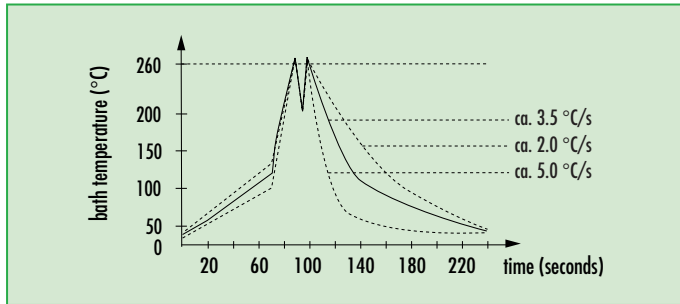

Marking

frequency
company code / date code



B.C.E. s.r.l.
Via Regina Pacis, 54/c - 41049 SASSUOLO (MO) Italy
Tel. +39 0536 811.616 r.a. - Fax +39 0536 811.500
www.bce.it - E-mail: bce@bce.it





actual size

Quartz Crystal · MQ5-SMC

UM5-SMD Crystal Version · 9.7 x 7.7 mm

- automotive temperature range available
- reflow soldering temperature: 260 °C max.
- package height 3.6 mm max.



General Data

type	MQ5 (UM5-SMC)
frequency range	10.0 ~ 40.0 MHz (fund. AT-cut)
	30.0 ~ 105.0 MHz (3rd OT AT-cut)
	50.0 ~ 175.0 MHz (5th OT AT-cut)
	70.0 ~ 250.0 MHz (7th OT AT-cut)
frequency tolerance at 25 °C	± 5 ppm ~ ± 30 ppm
load capacitance C_L	8 pF ~ 30 pF or series
shunt capacitance C_0	< 7 pF
storage temperature	-55 °C ~ +125 °C
drive level max.	500 μ W (100 μ W recommended)
aging	< ± 3 ppm first year

Dimensions

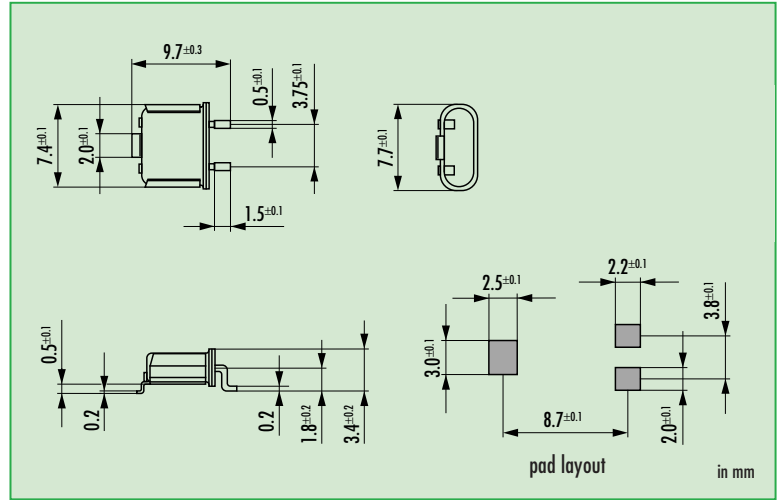

Frequency Stability vs. Temperature

	± 3 ppm	± 5 ppm	± 10 ppm	± 30 ppm	± 50 ppm	± 100 ppm
0 °C ~ +60 °C	○	○	○			
-20 °C ~ +70 °C	STD.	○	○	●		
-40 °C ~ +85 °C	T1		○	○	●	
-40 °C ~ +90 °C	T4			○	○	○
-40 °C ~ +105 °C	T2			○	○	○
-40 °C ~ +125 °C	T3					

● standard
○ available

ESR (series resistance R_s)

frequency in MHz	vibration mode	ESR max. in Ω	ESR typ. in Ω
10.0 ~ 19.999	fund.- AT	60	40
20.0 ~ 40.000	fund.- AT	40	20
30.0 ~ 79.999	3rd OT - AT	100	70
80.0 ~ 105.00	3rd OT - AT	80	50
50.0 ~ 59.999	5th OT - AT	250	200
60.0 ~ 129.99	5th OT - AT	200	160
130.0 ~ 175.0	7th OT - AT	180	150

Order Information

Q	frequency	type	load capacitance in pF	stability at 25 °C	stability vs. temp. range	option	SMD version
Quartz	10.0 ~ 250.0 MHz	MQ5	8 pF ~ 30 pF S for series	± 5 ~ ± 30 ppm	see table	blank = -20 °C ~ + 70 °C T1 = -40 °C ~ + 85 °C T2 = -40 °C ~ +105 °C T3 = -40 °C ~ +125 °C T4 = -40 °C ~ + 90 °C FU = for fundamental frequencies ≥ 20 MHz 30T = 3rd overtone 50T = 5th overtone 70T = 7th overtone	SMC

Example: Q 30.0-MQ5-30-30/50-T1-FU-SMC-LF (Suffix LF = RoHS compliant / Pb free pins or pads)



Quartz Crystal · MQ5-SMC

Taping Specification

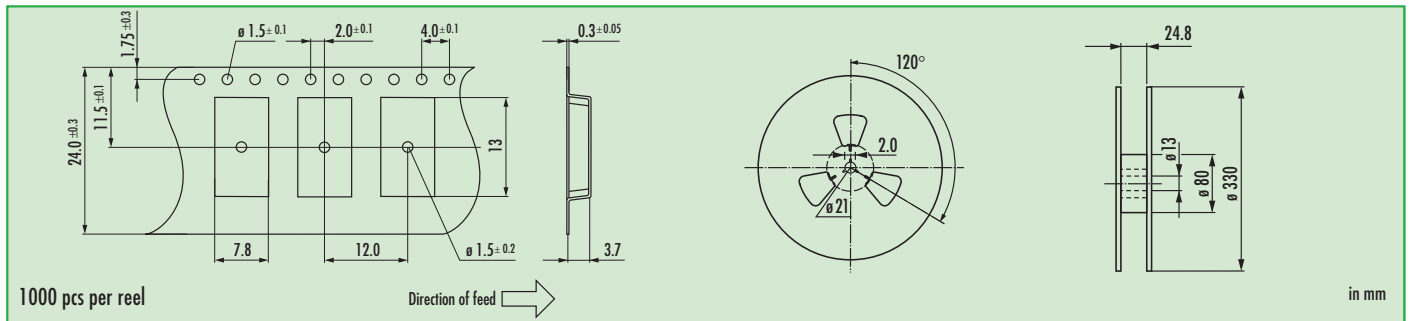

Reflow Soldering Profile

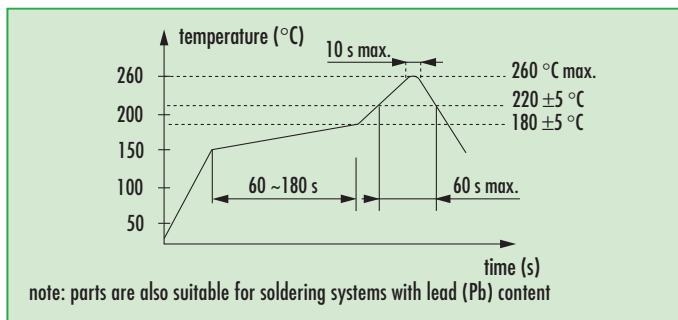

Marking

frequency
company code / date code





actual size

Quartz Crystal · MTF38

Pin Type Crystal · 3.0 x 8.9 mm

- wave soldering temperature: 260 °C max.
- 3 x 8 mm cylinder type



General Data

type	MTF38
frequency range	3.50 ~ 40.0 MHz (fund. AT-cut) 30.0 ~ 48.0 MHz (3rd OT. AT-cut; ask, if higher frequencies are available)
frequency tolerance at 25 °C	± 15 ppm ~ ± 30 ppm
load capacitance C_L	12 pF ~ 32 pF or series
shunt capacitance C_0	< 5 pF
storage temperature	-40 °C ~ +90 °C
drive level max.	500 µW (100 µW recommended)
aging	< ± 5 ppm first year

ESR (series resistance R_s)

frequency in MHz	vibration mode	ESR max. in Ω	ESR typ. in Ω
3.50 ~ 3.6999	fund.- AT	180	80
3.70 ~ 4.0999	fund.- AT	150	60
4.10 ~ 5.9999	fund.- AT	120	40
6.00 ~ 9.9999	fund.- AT	70	30
10.0 ~ 13.999	fund.- AT	50	20
14.0 ~ 40.000	fund.- AT	40	15
30.0 ~ 48.000	3rd OT - AT	100	80

Frequency Stability vs. Temperature

		± 20 ppm	± 30 ppm	± 50 ppm
-20 °C ~ +70 °C	STD.	○	●	
-40 °C ~ +85 °C	T1		○	●

● standard
○ available

Marking

frequency with load capacitance code company code / date code		Jan.	Febr.	Mar.	Apr.	May	June	July	Aug.	Sept.	Okt.	Nov.	Dec.
2011	2015	a	b	c	d	e	f	g	h	i	j	k	l
2012	2016	n	p	q	r	s	t	u	v	w	x	y	z
2013	2017	A	B	C	D	E	F	G	H	J	K	L	M
2014	2018	N	P	Q	R	S	T	U	V	W	X	Y	Z

Dimensions

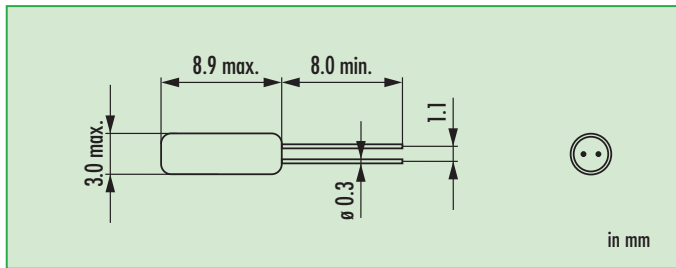

Load Capacitance Codes

7 pF: m	13 pF: v	20 pF: c	32 pF: e
8 pF: k	14 pF: x	22 pF: g	series: s
9 pF: n	15 pF: j	24 pF: d	T: 3rd OT
10 pF: h	16 pF: b	25 pF: r	
11 pF: l	17 pF: t	27 pF: w	
12 pF: a	18 pF: f	30 pF: .	

example 4.0 MHz / 12 pF: 4a000

Mounting

Mounting: if the crystal should be mounted vertically to your board (see picture), do not directly solder the metal can. The crystal may be overheated by the direct heat flow. Please use glue (hot-melt adhesive) or mechanical clamping to fasten the metal can.

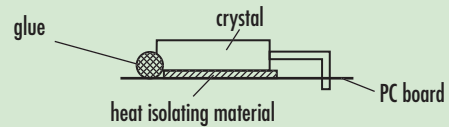

Order Information

Q	frequency	type	load capacitance in pF	stability at 25 °C	stability vs. temp. range	option
Quartz	3.50 ~ 48.0 MHz	MTF38	30 pF standard 12 pF ~ 32 pF S for series	30 = ± 30 ppm std	see table	blank = -20 °C ~ +70 °C T1 = -40 °C ~ +85 °C FU = for fundamental frequencies ≥ 20 MHz 30T = 3rd overtone

Example: Q 30.0-MTF38-30-30/30-FU







actual size

Quartz Crystal · JTX210

SMD Tuning Fork Crystal · 2.0 x 1.2 mm

- 32.768 kHz
- reflow soldering temperature: 260 °C max.
- package height 0.6 mm max.



General Data

type	JTX210
frequency	32.768 kHz
frequency tolerance at 25 °C ± 5 °C	± 20 ppm / ± 30 ppm
load capacitance C_L	12.5 pF std. / 9.0 pF / 7.0 pF
temperature constant (T_C)	$T_C = -0.04 \cdot 10^{-6} / ^\circ\text{C}^2$ max. $T_C = -0.034 \cdot 10^{-6} / ^\circ\text{C}^2$ typical
frequency temperature characteristic	f (ppm) = $T_C \cdot (25^\circ\text{C} - T)^2$ T = requested temperature
operating temperature range	-20 °C ~ +70 °C / -40 °C ~ +85 °C
shunt capacitance C_0	1.3 pF typical
series resistance max. (ESR)	90 k Ω
storage temperature	-55 °C ~ +125 °C
drive level max.	0.5 μ W
aging first year	< ± 3 ppm

Frequency Stability vs. Temperature

		- 80 ppm	- 160 ppm
-20 °C ~ +70 °C	STD.	●	
-40 °C ~ +85 °C	T1		●
● standard			

Marking

T / CL code / date code / internal code

CL code: A = 12.5 pF, B = 9 pF, C = 7 pF

	Jan.	Febr.	Mar.	Apr.	May	June	July	Aug.	Sept.	Okt.	Nov.	Dec.
2012	n	p	q	r	s	t	u	v	w	x	y	z
2013	A	B	C	D	E	F	G	H	J	K	L	M
2014	N	P	Q	R	S	T	U	V	W	X	Y	Z
2015	a	b	c	d	e	f	g	h	i	k	l	m

Dimensions

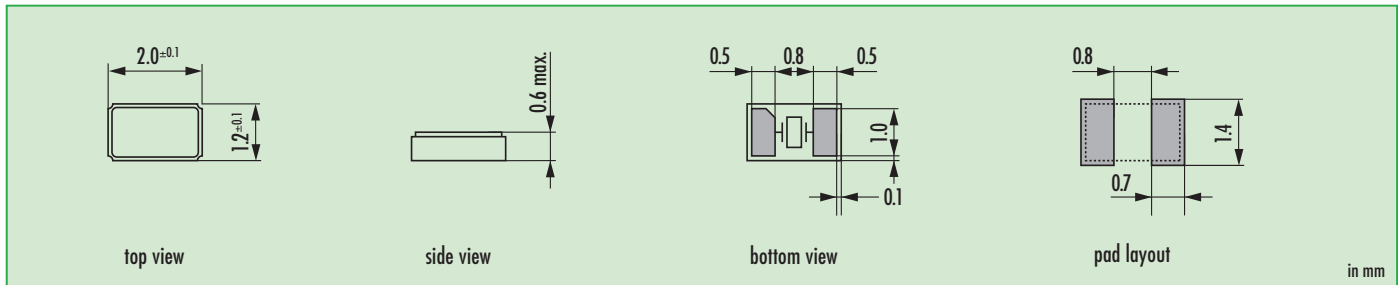

Order Information

Q	frequency	type	load capacitance	stability at 25 °C	option
Quartz	0.032768 MHz	JTX210	12.5 pF standard 9 pF 7 pF	20 = ± 20 ppm 30 = ± 30 ppm	blank = -20 °C ~ +70 °C T1 = -40 °C ~ +85 °C

Example: Q 0.032768-JTX210-12.5-20-T1-LF (Suffix LF = RoHS compliant / Pb free pads)



Quartz Crystal · JTX210

Taping Specification

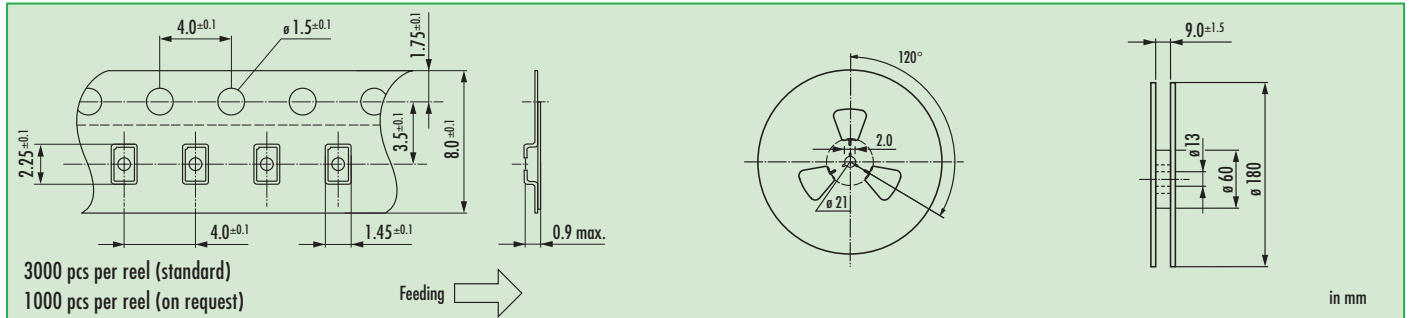

Reflow Soldering Profile

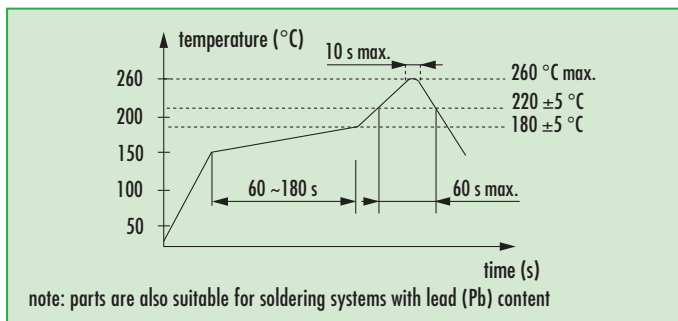



actual size

Quartz Crystal · JTX310

SMD Tuning Fork Crystal · 3.2 x 1.5 mm

- 32.768 kHz
- reflow soldering temperature: 260 °C max.
- package height 0.9 mm max.



General Data

type	JTX310
frequency	32.768 kHz
frequency tolerance at 25 °C ± 5 °C	± 10 ppm / ± 20 ppm / ± 30 ppm
load capacitance C_L	12.5 pF std. (6 pF ~ 9 pF on request)
temperature constant (T_C)	$T_C = -0.04 \cdot 10^{-6} / ^\circ C^2$ max. $T_C = -0.034 \cdot 10^{-6} / ^\circ C^2$ typical
frequency temperature characteristic	f (ppm) = $T_C \cdot (25^\circ C - T)^2$ T = requested temperature
operating temperature range	-20 °C ~ +70 °C / -40 °C ~ +85 °C
shunt capacitance C_0	1.15 pF typical
series resistance max. (ESR)	70 k Ω (60 k Ω ask if available)
storage temperature	-40 °C ~ +90 °C
drive level max.	0.5 μ W
aging first year	< ± 3 ppm

Frequency Stability vs. Temperature

		- 80 ppm	- 160 ppm	
-20 °C ~ +70 °C	STD.	●		
-40 °C ~ +85 °C	T1		●	
● standard				

Marking

company code
date code / production code

Dimensions

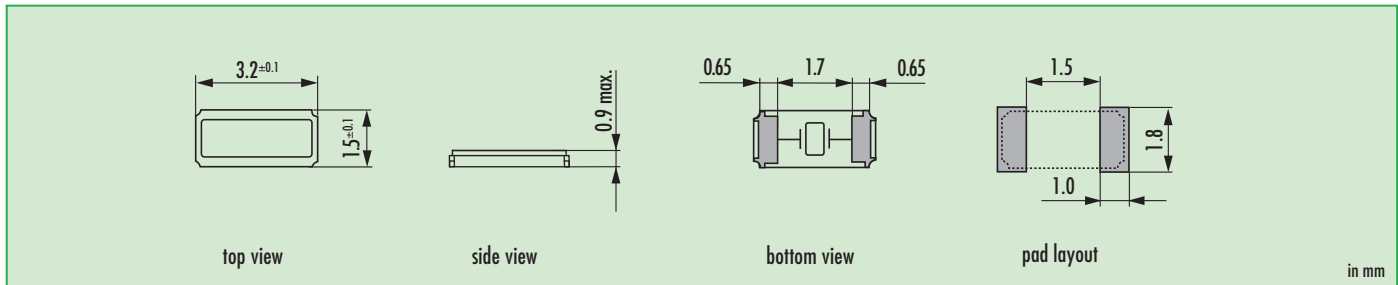

Order Information

Q	frequency	type	load capacitance	stability at 25 °C	option
Quartz	0.032768 MHz	JTX310	12.5 pF 6 pF ~ 9 pF (on request)	10 = ± 10 ppm 20 = ± 20 ppm 30 = ± 30 ppm	blank = -20 °C ~ +70 °C T1 = -40 °C ~ +85 °C

Example: Q 0.032768-JTX310-12.5-20-T1-LF (Suffix LF = RoHS compliant / Pb free pads)



Quartz Crystal · JTX310

Taping Specification

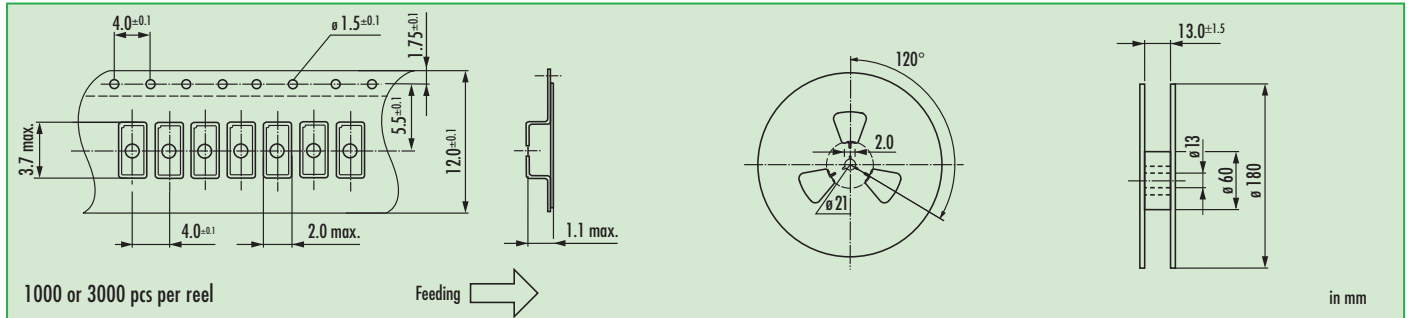

Reflow Soldering Profile

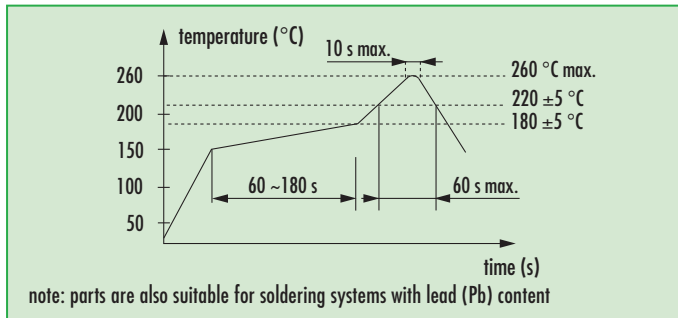



actual size

Quartz Crystal · JTX410

SMD Tuning Fork Crystal · 4.1 x 1.5 mm

- 32.768 kHz
- reflow soldering temperature: 260 °C max.
- package height 0.9 mm max.



General Data

type	JTX410
frequency	32.768 kHz
frequency tolerance at 25 °C ± 5 °C	± 10 ppm / ± 20 ppm / ± 30 ppm
load capacitance C_L	12.5 pF std. (7 pF ~ 10 pF on request)
temperature constant (T_C)	$T_C = -0.04 \cdot 10^{-6} / ^\circ\text{C}^2$ max. $T_C = -0.034 \cdot 10^{-6} / ^\circ\text{C}^2$ typical
frequency temperature characteristic	$f(\text{ppm}) = T_C \cdot (25^\circ\text{C} - T)^2$ T = requested temperature
operating temperature range	-20 °C ~ +70 °C / -40 °C ~ +85 °C
shunt capacitance C_0	1.2 pF typical
series resistance max. (ESR)	80 kΩ (70 kΩ or 60 kΩ ask if available)
storage temperature	-40 °C ~ +90 °C
drive level max.	0.5 μW
aging first year	< ± 3 ppm

Frequency Stability vs. Temperature

		- 80 ppm	- 160 ppm	
-20 °C ~ +70 °C	STD.	●		
-40 °C ~ +85 °C	T1		●	
● standard				

Marking

company code
date code / production code

Dimensions

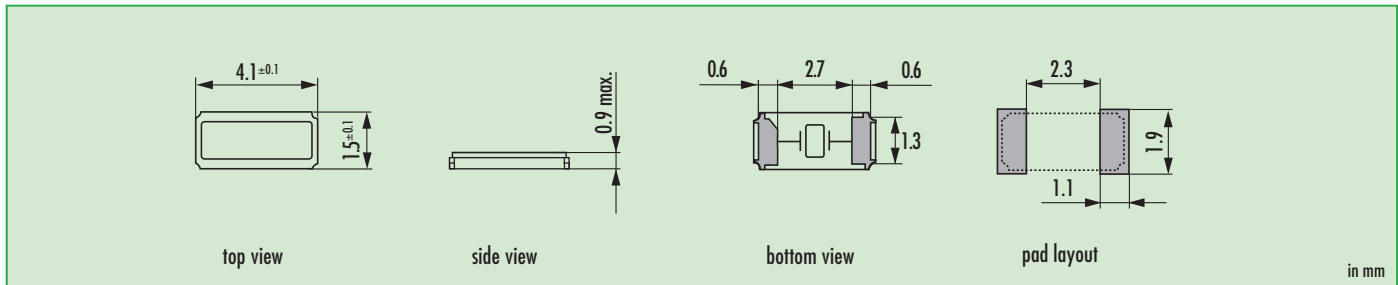

Order Information

Q	frequency	type	load capacitance	tolerance at 25 °C	option
Quartz	0.032768 MHz	JTX410	12.5 pF 7 pF ~ 10 pF (on request)	10 = ± 10 ppm 20 = ± 20 ppm 30 = ± 30 ppm	blank = -20 °C ~ +70 °C T1 = -40 °C ~ +85 °C

Example: Q 0.032768-JTX410-12.5-20-T1-LF (Suffix LF = RoHS compliant / Pb free pads)





actual size

Quartz Crystal · JTX520

SMD Tuning Fork Crystal · 4.8 x 1.9 mm

- 32.768 kHz standard
- reflow soldering temperature: 260 °C max.
- package height 1.0 mm max.



General Data

type	JTX520
frequency	32.768 kHz (30.0 ~ 100.0 kHz on request)
frequency tolerance at 25 °C ± 5 °C	± 10 ppm / ± 20 ppm / ± 30 ppm
load capacitance C_L	12.5 pF std. (7 pF ~ 12 pF on request)
temperature constant (T_C)	$T_C = -0.04 \cdot 10^{-6} / ^\circ C^2$ max. $T_C = -0.034 \cdot 10^{-6} / ^\circ C^2$ typical
frequency temperature characteristic	f (ppm) = $T_C \cdot (25^\circ C - T)^2$ T = requested temperature
operating temperature range	-20 °C ~ +70 °C / -40 °C ~ +85 °C
shunt capacitance C_0	1.25 pF typical
series resistance max. (ESR)	80 k Ω (70 k Ω ask if available)
storage temperature	-40 °C ~ +90 °C
drive level max.	1.0 μ W
aging first year	< ± 3 ppm

Frequency Stability vs. Temperature

		- 80 ppm	- 160 ppm	
-20 °C ~ +70 °C	STD.	●		
-40 °C ~ +85 °C	T1		●	
● standard				

Marking

company code
frequency code (optional)
date code
production code (optional)

Dimensions

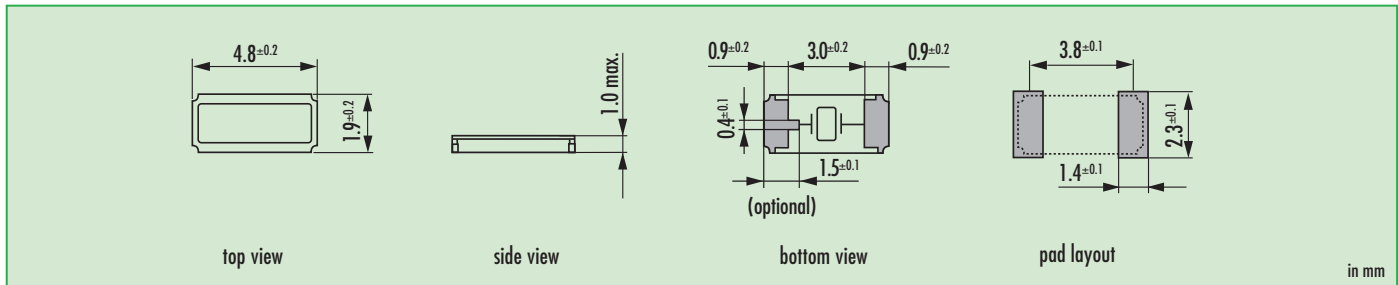

Order Information

Q	frequency	type	load capacitance	tolerance at 25 °C	option
Quartz	0.032768 MHz	JTX520	7 ~ 12.5 pF 12.5 pF std.	10 = ± 10 ppm 20 = ± 20 ppm 30 = ± 30 ppm	blank = -20 °C ~ +70 °C T1 = -40 °C ~ +85 °C

Example: Q 0.032768-JTX520-12.5-20-T1-LF (Suffix LF = RoHS compliant / Pb free pads)



Quartz Crystal · JTX520

Taping Specification

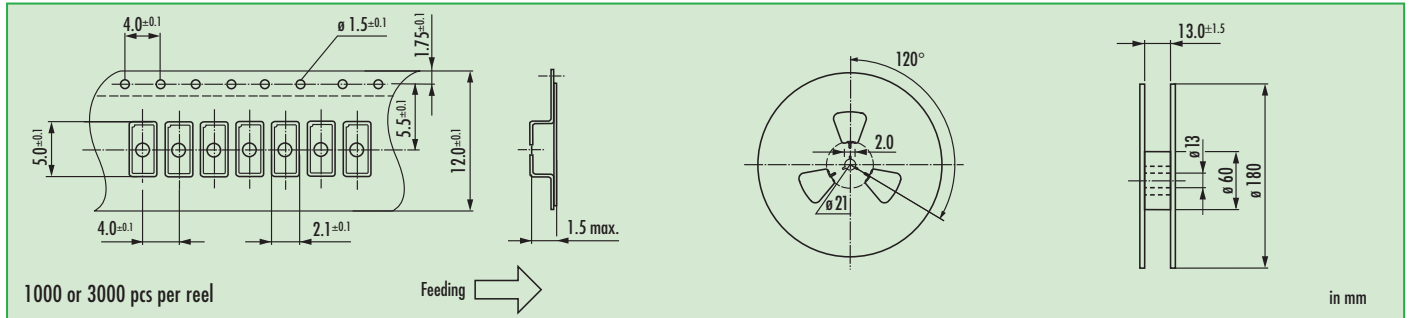

Reflow Soldering Profile

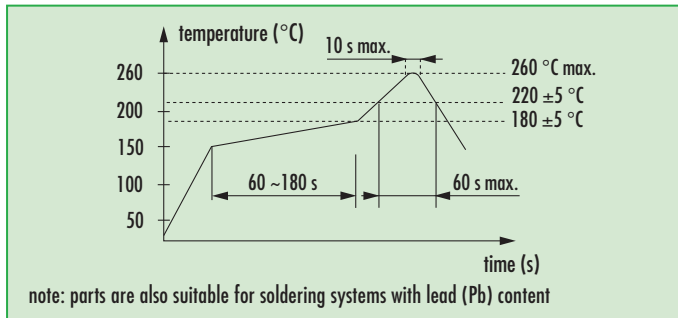



actual size

Quartz Crystal · SMQ32SN

SMD Tuning Fork Crystal · 7.0 x 1.5 mm

- 32.768 kHz standard
- reflow soldering temperature: 260 °C max.
- package height 1.4 mm max.



General Data

type	SMQ32SN
frequency	32.768 kHz
frequency tolerance at 25 °C ± 5 °C	±20 ppm / ±30 ppm
load capacitance C_L	12.5 pF / 7 pF
temperature constant (T_C)	$T_C = -0.04 \cdot 10^{-6} / ^\circ\text{C}^2$ max. $T_C = -0.034 \cdot 10^{-6} / ^\circ\text{C}^2$ typical
frequency temperature characteristic	$f(\text{ppm}) = T_C \cdot (25^\circ\text{C} - T)^2$ T = requested temperature
operating temperature range	-20 °C ~ +70 °C / -40 °C ~ +85 °C
shunt capacitance C_0	0.8 pF typical
series resistance max. (ESR)	65 kΩ (12.5 pF) 70 kΩ (7 pF)
storage temperature	-55 °C ~ +125 °C
drive level max.	1 μW
aging first year	< ± 3 ppm

Frequency Stability vs. Temperature

		- 80 ppm	- 160 ppm
-20 °C ~ +70 °C	STD.	●	
-40 °C ~ +85 °C	T1		●
● standard			

Marking

internal code / frequency code / date code (my) / CL code

frequency code:

KHz	Code
32.768	3

month code:

Jan.	Febr.	Mar.	Apr.	May	June
A	B	C	D	E	F

CL code:

CL (pF)	Code
12.5	C
7.0	7

year code:

2013	2014	2015	2016	2017	2018	2019
D	E	F	G	H	J	K

example: C3 ED C, ED = May 2013, C = 12.5pF

Dimensions

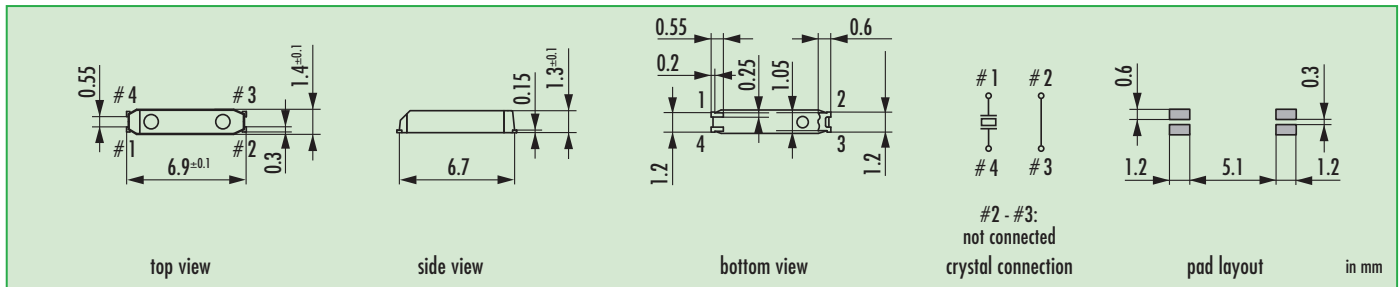

Order Information

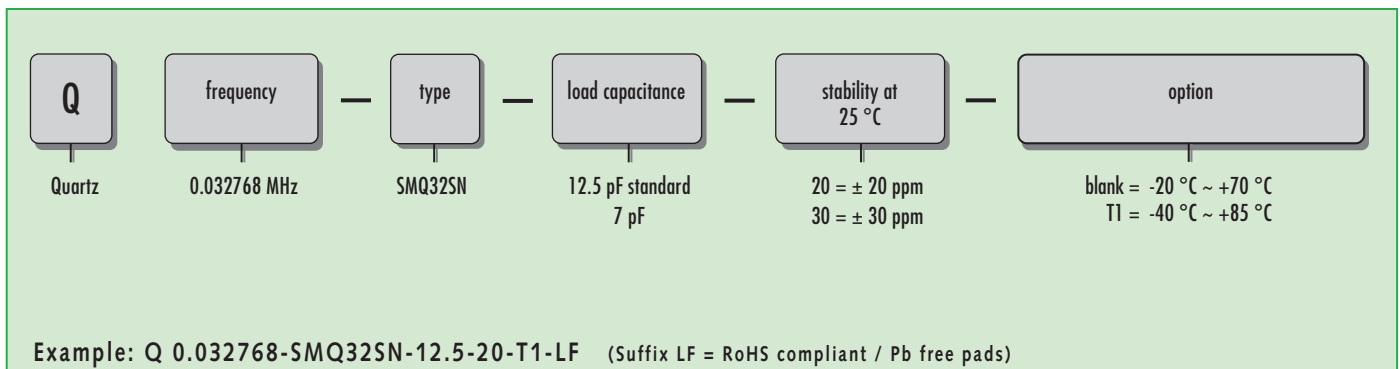

Quartz Crystal · SMQ32SN

Taping Specification

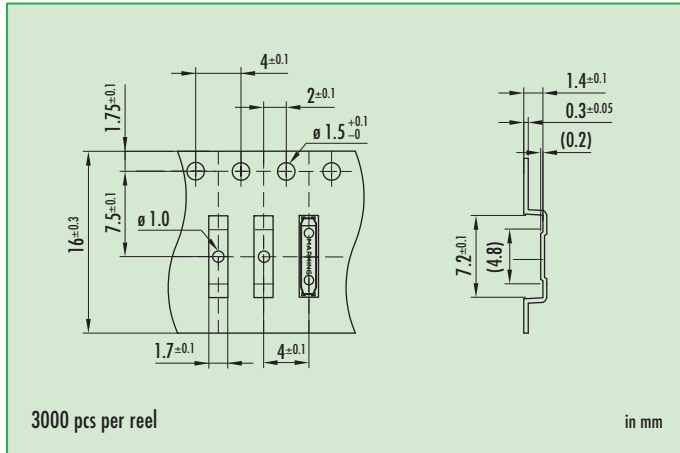

Reflow Soldering Profile

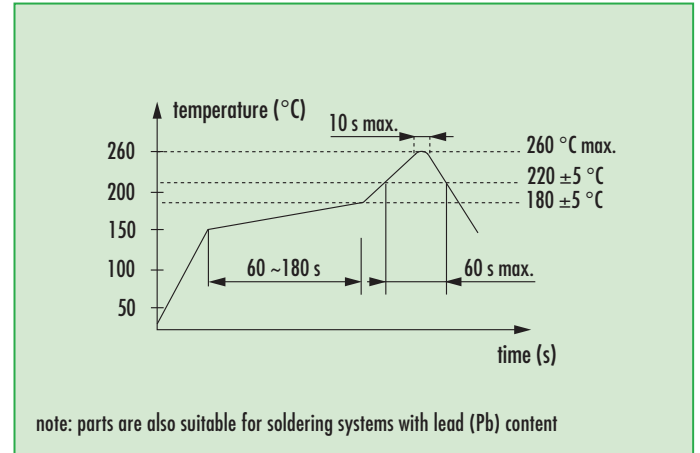



actual size

Quartz Crystal · SMQ32SL

SMD Tuning Fork Crystal · 8.0 x 3.8 mm

- 32.768 kHz standard
- reflow soldering temperature: 260 °C max.
- package height 2.5 mm max.



General Data

type	SMQ32SL
frequency	32.768 kHz (30.0 ~ 100.0 kHz on request)
frequency tolerance at 25 °C ± 5 °C	±20 ppm / ±30 ppm ±10 ppm (ask if available)
load capacitance C_L	12.5 pF std. (6 pF ~ 16 pF on request)
temperature constant (T_C)	$T_C = -0.04 \cdot 10^{-6} / ^\circ C^2$ max. $T_C = -0.034 \cdot 10^{-6} / ^\circ C^2$ typical
frequency temperature characteristic	f (ppm) = $T_C \cdot (25^\circ C - T)^2$ T = requested temperature
operating temperature range	-20 °C ~ +70 °C / -40 °C ~ +85 °C
shunt capacitance C_0	1.3 pF typical
series resistance max. (ESR)	50 kΩ (35 kΩ ask if available)
storage temperature	-40 °C ~ +90 °C
drive level max.	1 μW
aging first year	< ± 3 ppm

Frequency Stability vs. Temperature

		- 80 ppm	- 160 ppm	
-20 °C ~ +70 °C	STD.	●		
-40 °C ~ +85 °C	T1		●	
● standard				

Marking

frequency (optional)
internal code / date code

Dimensions

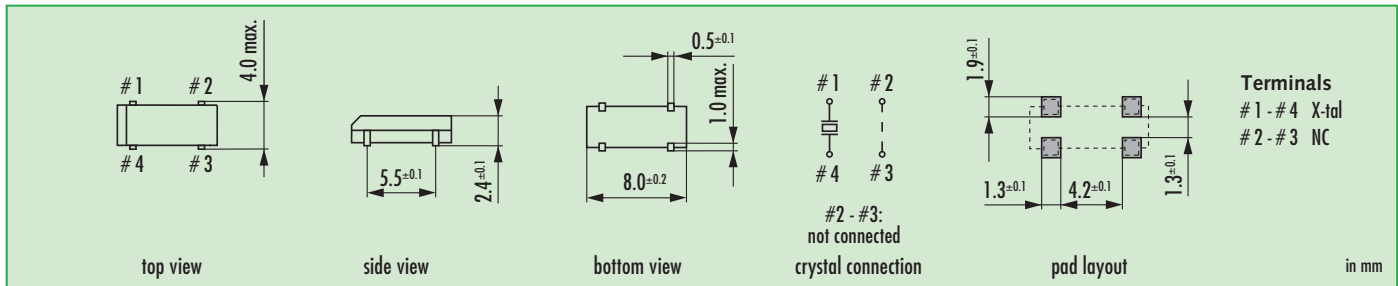

Order Information

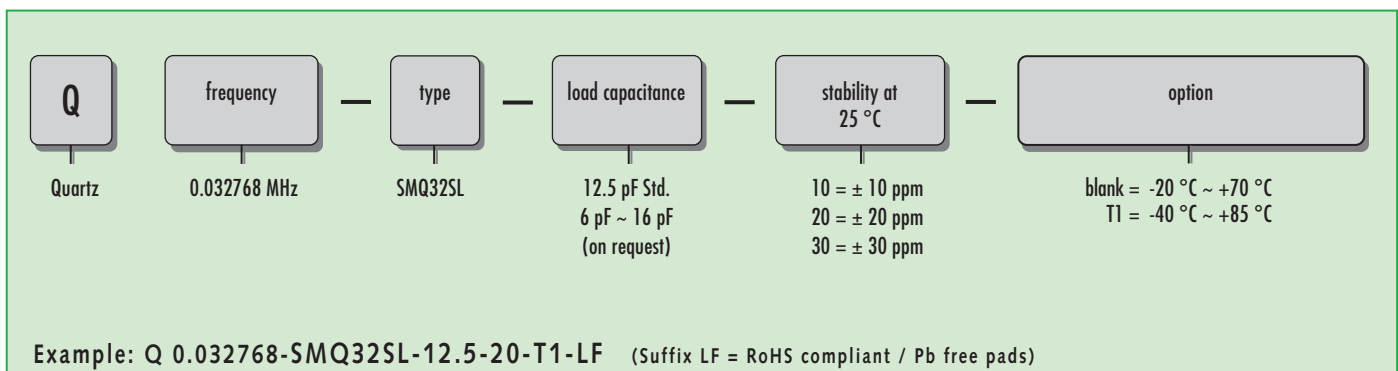

Quartz Crystal · SMQ32SL

Taping Specification

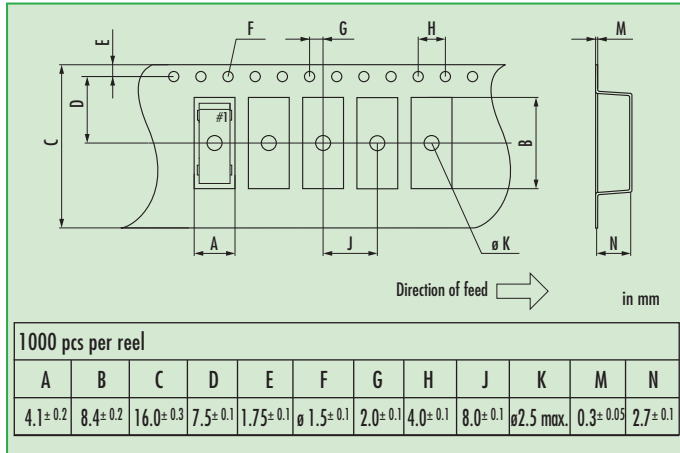

Reflow Soldering Profile

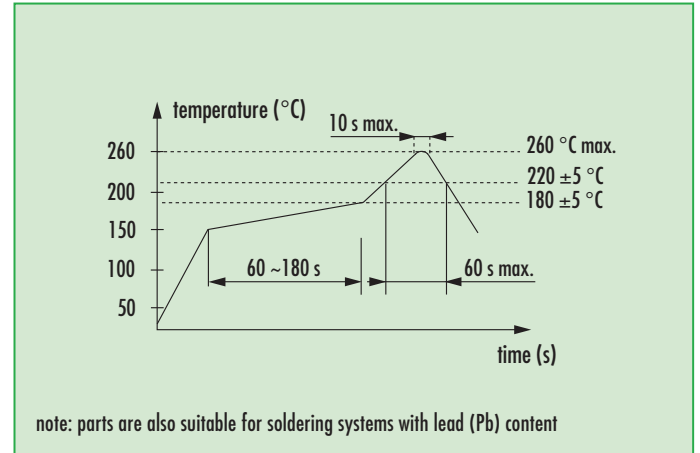



actual size

Quartz Crystal · SMQ32S

SMD Tuning Fork Crystal · 9.2 x 3.4 mm

- 32.768 kHz standard
- reflow soldering temperature: 260 °C max.
- package height 3.0 mm



General Data

type	SMQ32S
frequency	32.768 kHz (30.0 ~ 80.0 kHz on request)
frequency tolerance at 25 °C ± 5 °C	± 30 ppm
load capacitance C_L	12.5 pF std. (6 pF ~ 12.5 pF on request)
temperature constant (T_C)	$T_C = -0.04 \cdot 10^{-6} / ^\circ\text{C}^2$ max. $T_C = -0.034 \cdot 10^{-6} / ^\circ\text{C}^2$ typical
frequency temperature characteristic	$f(\text{ppm}) = T_C \cdot (25^\circ\text{C} - T)^2$ T = requested temperature
operating temperature range	-20 °C ~ +70 °C / -40 °C ~ +85 °C
shunt capacitance C_0	1.4 pF typical
series resistance max. (ESR)	50 k Ω
storage temperature	-40 °C ~ +90 °C
drive level max.	1 μW
aging first year	< ± 3 ppm

Frequency Stability vs. Temperature

		- 80 ppm	- 160 ppm
-20 °C ~ +70 °C	STD.	●	
-40 °C ~ +85 °C	T1		●

● standard

Marking

company code / 32.7 / date code

date code:

Jan.	Febr.	Mar.	Apr.	May	June
A	B	C	D	E	F

July	Aug.	Sept.	Oct.	Nov.	Dec.
G	H	J	K	L	M

A ~ M: Jan.- Dec.
1: 2011 4: 2014
2: 2012 5: 2015
3: 2013 6: 2016

Dimensions

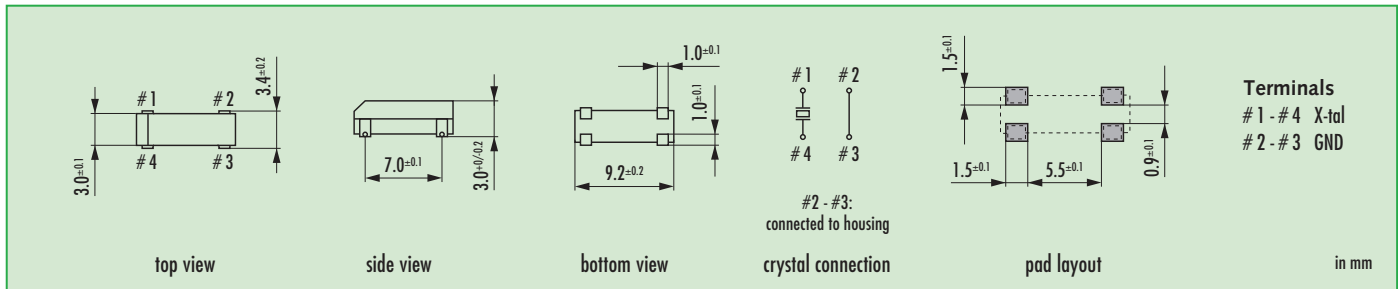

Order Information

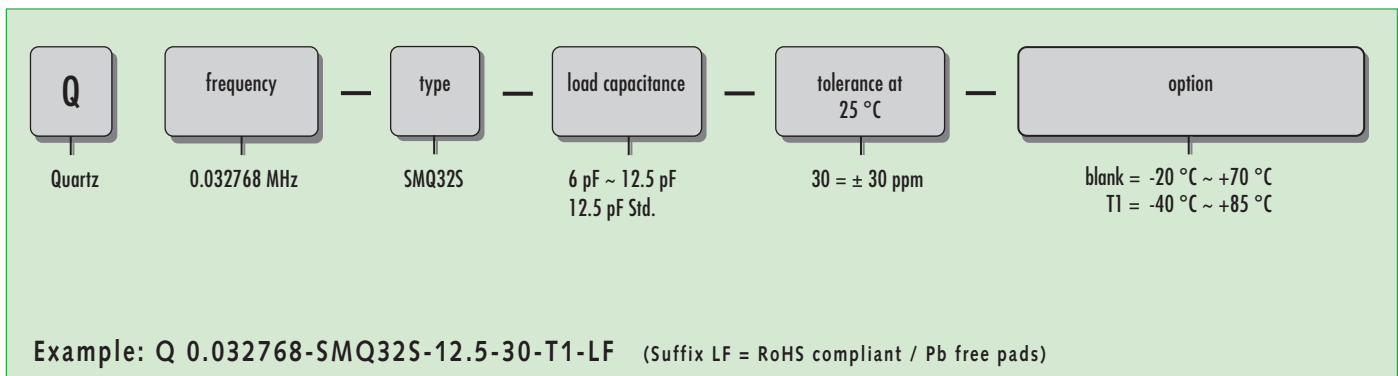

Quartz Crystal · SMQ32S

Taping Specification

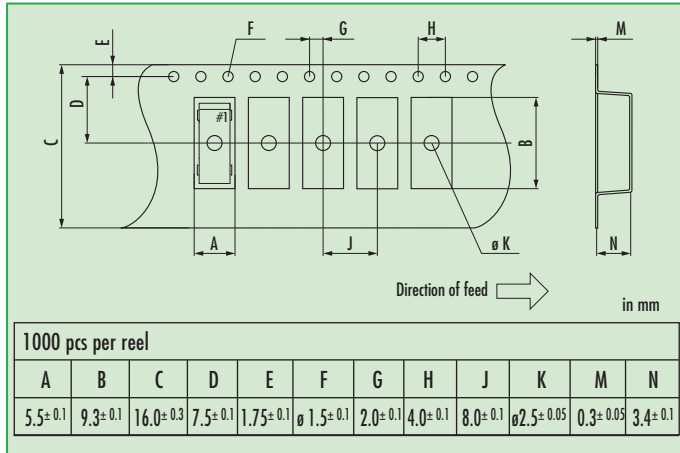

Reflow Soldering Profile

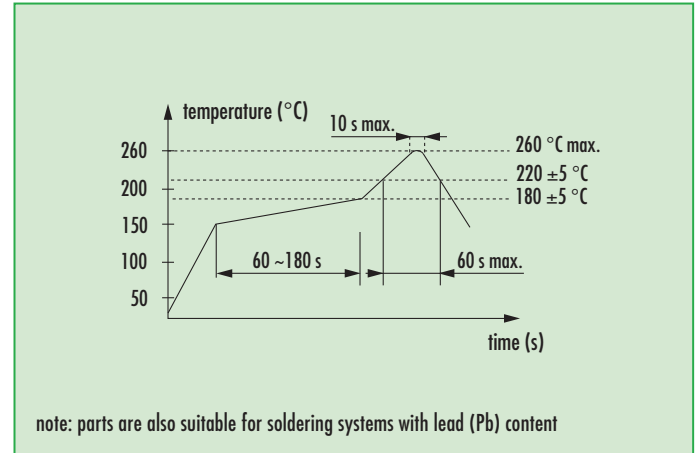

B.C.E. s.r.l.
Via Regina Pacis, 54/c - 41049 SASSUOLO (MO) Italy
Tel. +39 0536 811.616 r.a. - Fax +39 0536 811.500
www.bce.it - E-mail: bce@bce.it





actual size

Quartz Crystal · SMQ32

SMD Tuning Fork Crystal · 13.2 x 4.9 mm

- 32.768 kHz standard
- reflow soldering temperature: 260 °C max.
- package height 4.8 mm max.



General Data

type	SMQ32
frequency	32.768 kHz (30.0 ~ 80.0 kHz on request)
frequency tolerance at 25 °C ± 5 °C	± 20 ppm / ± 30 ppm
load capacitance C_L	12.5 pF std. (6 pF ~ 12 pF on request)
temperature constant (T_C)	$T_C = -0.04 \cdot 10^{-6} / ^\circ\text{C}^2$ max. $T_C = -0.034 \cdot 10^{-6} / ^\circ\text{C}^2$ typical
frequency temperature characteristic	$f(\text{ppm}) = T_C \cdot (25^\circ\text{C} - T)^2$ T = requested temperature
operating temperature range	-20 °C ~ +70 °C / -40 °C ~ +85 °C
shunt capacitance C_0	2 pF typical
series resistance max. (ESR)	33.0 k Ω
storage temperature	-40 °C ~ +90 °C
drive level max.	1 μW
aging first year	< ± 5 ppm

Frequency Stability vs. Temperature

		- 80 ppm	- 160 ppm
-20 °C ~ +70 °C	STD.	●	
-40 °C ~ +85 °C	T1		●
● standard			

Marking

company code / 327 / date code

date code:

Jan.	Febr.	Mar.	Apr.	May	June
A	B	C	D	E	F
July	Aug.	Sept.	Oct.	Nov.	Dec.
G	H	J	K	L	M

A ~ M: Jan. - Dec.

1: 2011 4: 2014
2: 2012 5: 2015
3: 2013 6: 2016

Dimensions

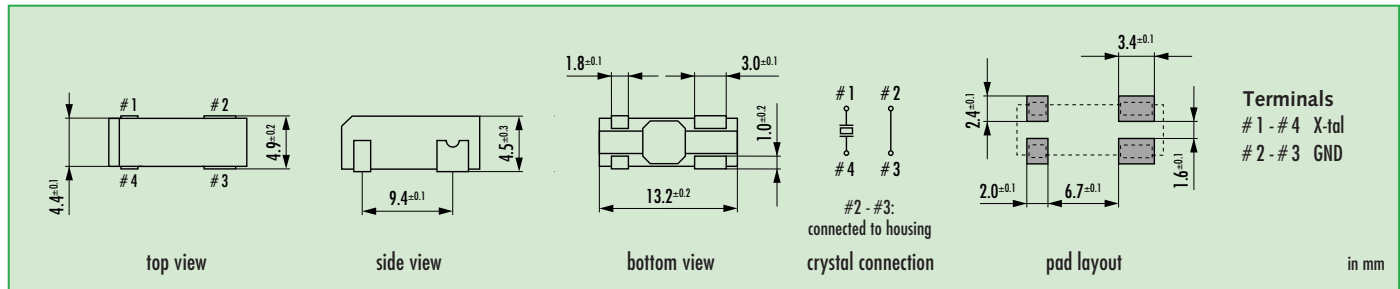

Order Information

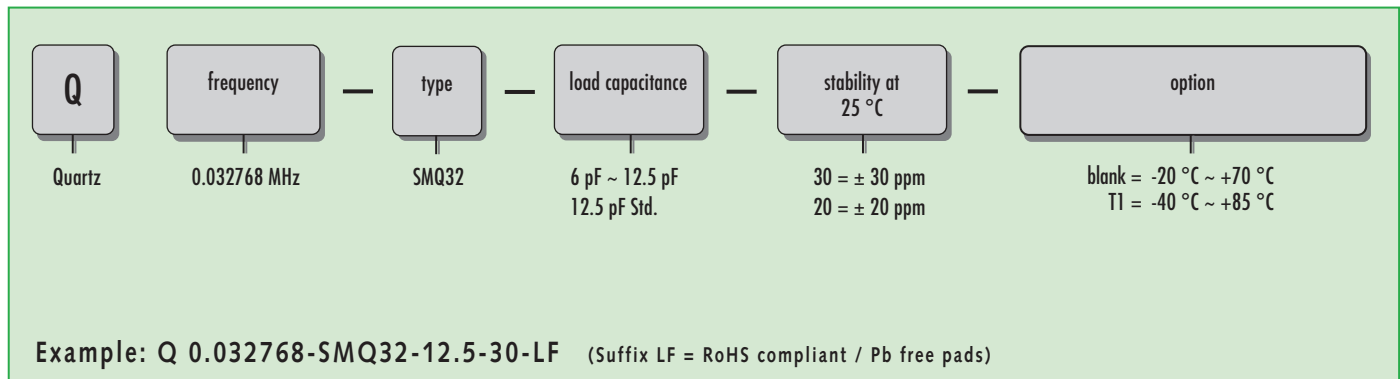

Quartz Crystal · SMQ32

Taping Specification

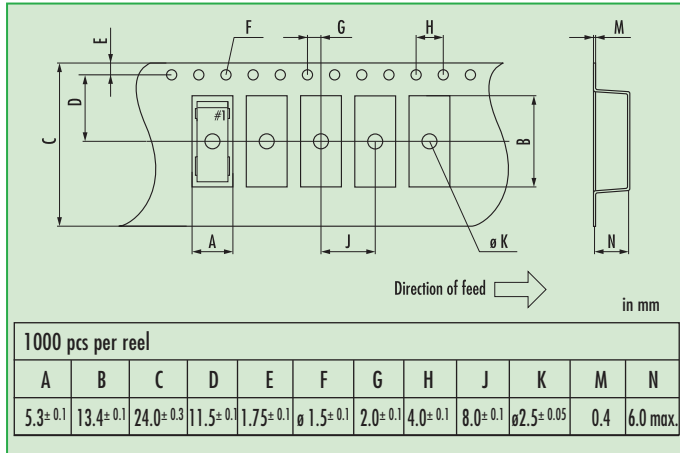

Reflow Soldering Profile

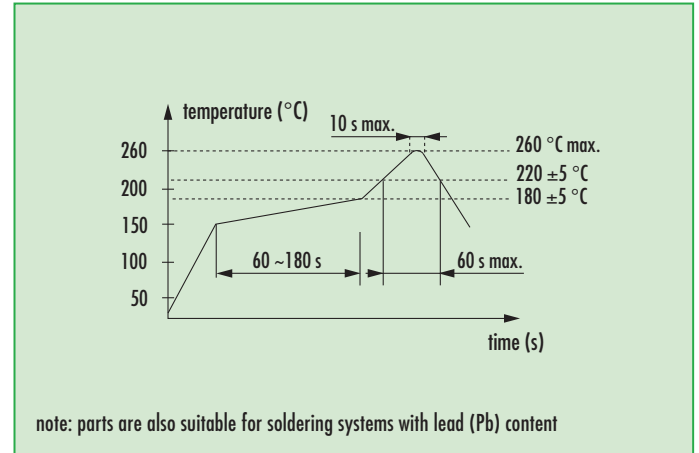

B.C.E. s.r.l.
Via Regina Pacis, 54/c - 41049 SASSUOLO (MO) Italy
Tel. +39 0536 811.616 r.a. - Fax +39 0536 811.500
www.bce.it - E-mail: bce@bce.it





actual size

Quartz Crystal · SM26F

Tuning Fork Crystal · 2.0 x 6.0 mm

- 2 x 6 mm cylinder type
- reflow soldering temperature: 260 °C max.
- package height: 2.1 / 3.25 mm max.



General Data

type	SM26F
frequency	32.768 kHz (30.0 ~ 100.0 kHz on request)
frequency tolerance at 25 °C ± 5 °C	± 20 ppm / ± 30 ppm (± 10 ppm ask if available)
load capacitance C _L	12.5 pF std. (6 pF ~ 12.5 pF on request)
temperature constant (T _C)	T _C = -0.04 · 10 ⁻⁶ / °C ² max. T _C = -0.034 · 10 ⁻⁶ / °C ² typical
frequency temperature characteristic	f (ppm) = T _C · (25 °C - T) ² T = requested temperature
operating temperature range	-20 °C ~ +70 °C / -40 °C ~ +85 °C
shunt capacitance C ₀	1.2 pF typical
series resistance max. (ESR)	50.0 kΩ (35.0 kΩ ask if available)
storage temperature	-40 °C ~ +90 °C
drive level max.	1 μW
aging first year	< ± 5 ppm

Frequency Stability vs. Temperature

		- 80 ppm	- 160 ppm
-20 °C ~ +70 °C	STD.	●	
-40 °C ~ +85 °C	T1		●

● standard

Marking

company code
frequency code (optional)
date code

Dimensions type A

(1000 pcs per reel)

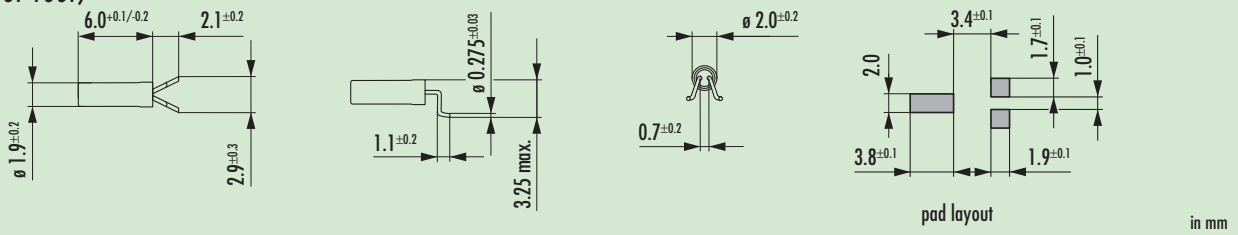

Dimensions type B

(1000 pcs per reel)

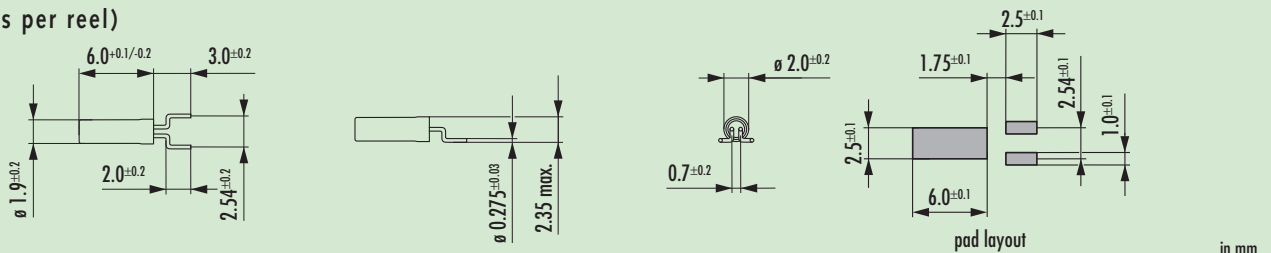

Order Information

Q	frequency	type	load capacitance	stability at 25 °C	dimensions type	option
Quartz	0.032768 MHz	SM26F	6 pF ~ 12.5 pF 12.5 pF Std.	20 = ± 20 ppm 30 = ± 30 ppm	A = lead type B = lead type	blank = -20 °C ~ +70 °C T1 = -40 °C ~ +85 °C

Example: Q 0.032768-SM26F-12.5-20-B-T1-LF







actual size

Quartz Crystal · MMTF32

Tuning Fork Crystal · 2.0 x 6.0 mm

- 2 x 6 mm cylinder type
- 32.768 kHz standard



General Data

type	MMTF32
frequency	32.768 kHz
frequency tolerance at 25 °C ± 5 °C	± 10 ppm / ± 20 ppm
load capacitance C _L	10 pF / 12.5 pF std. (6 pF ~ 12.5 pF on request)
temperature constant (T _C)	T _C = -0.04 · 10 ⁻⁶ / °C ² max. T _C = -0.034 · 10 ⁻⁶ / °C ² typical
frequency temperature characteristic	f (ppm) = T _C · (25 °C - T) ² T = requested temperature
operating temperature range	-20 °C ~ +70 °C / -40 °C ~ +85 °C
shunt capacitance C ₀	1.2 pF typical
series resistance max. (ESR)	40.0 kΩ (35.0 kΩ ask if available)
storage temperature	-40 °C ~ +90 °C
drive level max.	1 μW
aging first year	< ± 5 ppm

Frequency Stability vs. Temperature

		-80 ppm	-160 ppm	
-20 °C ~ +70 °C	STD.	●		
-40 °C ~ +85 °C	T1		●	
● standard				

Marking

company code
date code
internal code (optional)

Dimensions

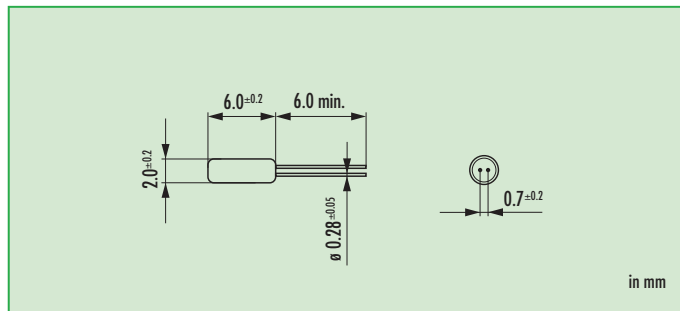

Wave Soldering Profile

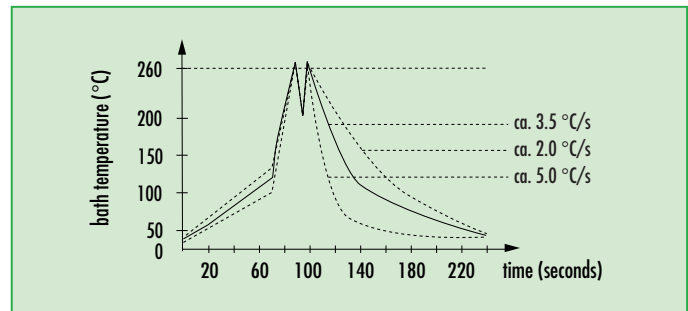

Mounting

Mounting: if the crystal should be mounted vertically to your board (see picture), do not directly solder the metal can. The crystal may be overheated by the direct heat flow. Please use glue (hot-melt adhesive) or mechanical clamping to fasten the metal can.

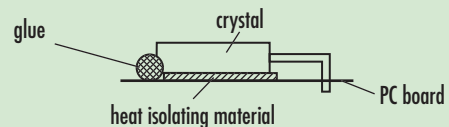

Order Information

Q	frequency	type	load capacitance	stability at 25 °C	option
Quartz	0.032768 MHz	MMTF32	6 pF ~ 12.5 pF 10.0 pF Std. 12.5 pF Std.	20 = ± 20 ppm 10 = ± 10 ppm	blank = -20 °C ~ +70 °C T1 = -40 °C ~ +85 °C

Example: Q 0.032768-MMTF32-12.5-20-LF (Suffix LF = RoHS compliant / Pb free pads)







actual size

Quartz Crystal · MTF32

Tuning Fork Crystal · 3.0 x 8.0 mm

- 3 x 8 mm cylinder type
- 32.768 kHz standard



General Data

type	MTF32
frequency	32.768 kHz
frequency tolerance at 25 °C ± 5 °C	± 10 ppm / ± 20 ppm
load capacitance C _L	10 pF/12.5 pF std. (6 pF ~ 12.5 pF on request)
temperature constant (T _C)	T _C = -0.04 · 10 ⁻⁶ / °C ² max. T _C = -0.034 · 10 ⁻⁶ / °C ² typical
frequency temperature characteristic	f (ppm) = T _C · (25 °C - T) ² T = requested temperature
operating temperature range	-20 °C ~ +70 °C / -40 °C ~ +85 °C
shunt capacitance C ₀	1.5 pF typical
series resistance max. (ESR)	30.0 kΩ (23.0 kΩ ask if available)
storage temperature	-40 °C ~ +90 °C
drive level max.	1 μW
aging first year	< ± 5 ppm

Frequency Stability vs. Temperature

		- 80 ppm	- 160 ppm
-20 °C ~ +70 °C	STD.	●	
-40 °C ~ +85 °C	T1		●
● standard			

Wave Soldering Profile

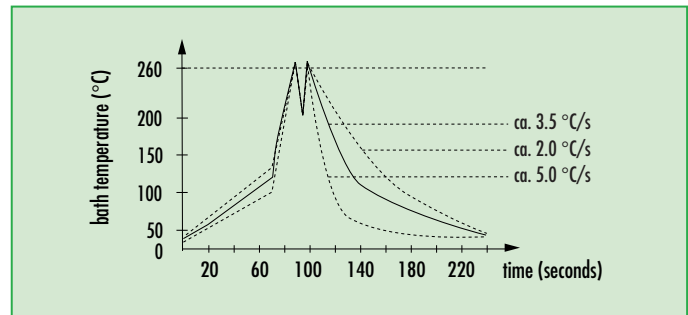

Dimensions

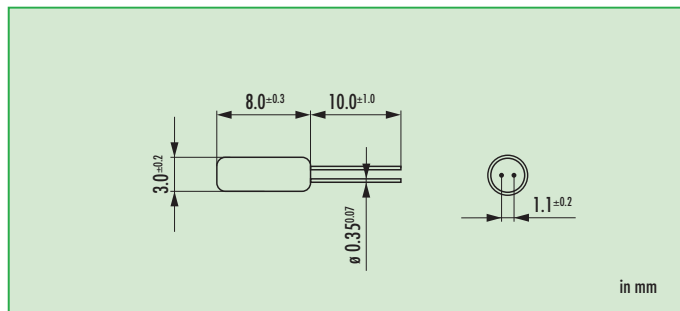

Marking

company code
date code
internal code (optional)

Mounting

Mounting: if the crystal should be mounted vertically to your board (see picture), do not directly solder the metal can. The crystal may be overheated by the direct heat flow. Please use glue (hot-melt adhesive) or mechanical clamping to fasten the metal can.

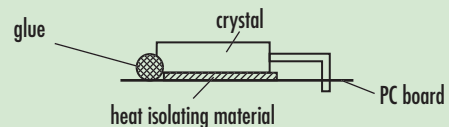

Order Information

Q	frequency	type	load capacitance	stability at 25 °C	option
Quartz	0.032768 MHz	MTF32	6 pF ~ 12.5 pF 10.0 pF Std. 12.5 pF Std.	20 = ± 20 ppm 10 = ± 10 ppm	blank = -20 °C ~ +70 °C T1 = -40 °C ~ +85 °C

Example: Q 0.032768-MTF32-12.5-20-LF (Suffix LF = RoHS compliant / Pb free pads)







actual size

SMD Quartz Crystal · JXS42

4 Pad Version · 4.0 x 2.5 mm

- ± 10 ppm type available
- ceramic / metal package
- wave soldering temperature: 260 °C max.



General Data

type	JXS42	
frequency range	12.0 ~ 12.99 MHz	(others on request)
frequency tolerance at 25 °C	± 10 ppm / ± 30 ppm	
load capacitance C_L	12 pF standard	(option: 8 pF ~ 30 pF / series)
shunt capacitance C_0	< 5 pF	
storage temperature	-40 °C ~ +90 °C	
drive level max.	100 µW	
aging	< ± 3 ppm first year	

ESR (series resistance R_s)

frequency in MHz	vibration mode	ESR max. in Ω	ESR typ. in Ω
12.0 ~ 12.999	fund. - AT	100	45
13.0 ~ 18.999	fund. - AT	80	40
19.0 ~ 24.999	fund. - AT	60	25
25.0 ~ 29.999	fund. - AT	50	25
30.0 ~ 39.999	fund. - AT	50	20
40.00 ~ 50.00	fund. - AT	40	20

Frequency Stability vs. Temperature

		± 10 ppm	± 15 ppm	± 20 ppm	± 30 ppm	± 50 ppm
-20 °C ~ +70 °C	STD.	○	○	○	●	○
-40 °C ~ +85 °C	T1		○	○	○	●

● standard
 ○ available

Marking

frequency with load capacitance code
 company code / date code / internal code

date code: year/month
 example: 6A = 2006 January

Jan.	Febr.	Mar.	Apr.	May	June
A	B	C	D	E	F

July	Aug.	Sept.	Oct.	Nov.	Dec.
G	H	J	K	L	M

Dimensions

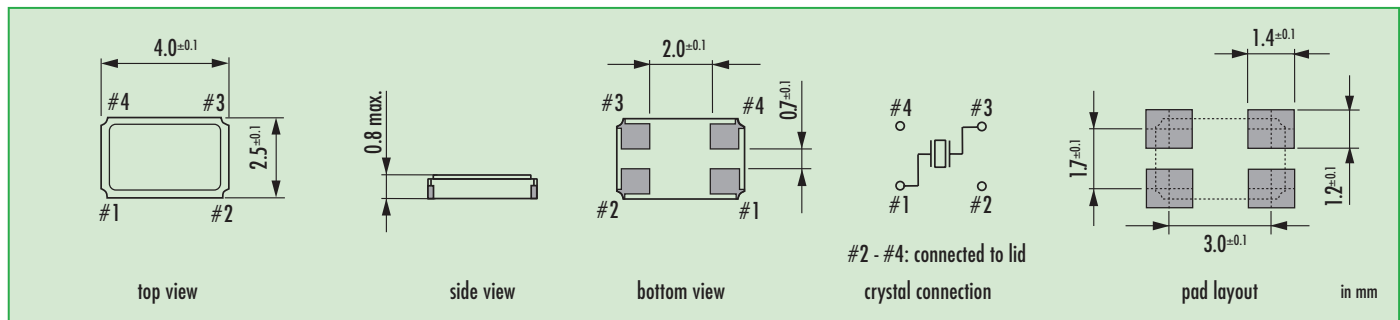

Order Information

Q	frequency	type	load capacitance	stability at 25 °C	stability vs. temp. range	option
Quartz	12.0 ~ 12.999 MHz	JXS42	12 pF standard 8 pF ~ 30 pF 5 for series	10 = ± 10 ppm 30 = ± 30 ppm	see table	blank = -20 °C ~ +70 °C T1 = -40 °C ~ +85 °C FU = for fundamental frequencies ≥ 20 MHz

Example: Q 12.0-JXS42-12-30/30 (Suffix LF = RoHS compliant / Pb free pins or pads)



SMD Quartz Crystal · JXS42

Taping Specification

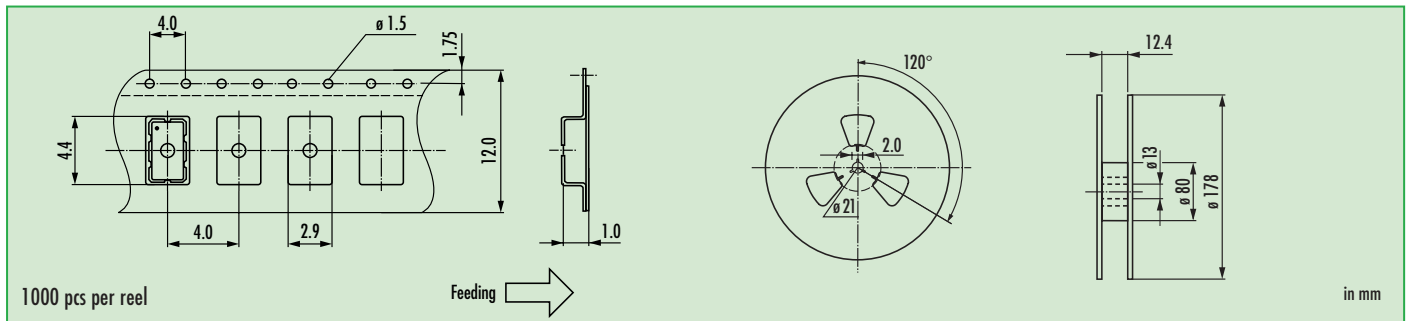

Reflow Soldering Profile

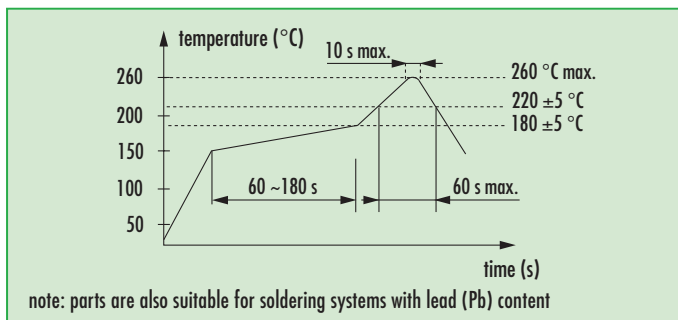

Load Capacitance Codes

8 pF: k	14 pF: x	22 pF: g	series: s
9 pF: n	15 pF: j	24 pF: d	T: 3rd OT
10 pF: h	16 pF: b	25 pF: r	
11 pF: l	17 pF: t	27 pF: w	
12 pF: a	18 pF: f	30 pF: .	
13 pF: v	20 pF: c		

example 20.0 MHz / 12 pF: 20a00







JAUCH QUARTZ...

...A COMPANY ON THE PULSE OF PROGRESS

1954 1960



Quartz – a material with fascinating properties. The most important one is piezoelectricity. What began at Jauch decades ago with the first quartz crystals for electronic clockworks has until today remained the core competence and most important product of our globally active, independent technology firm.

Availability – in today's production world it's a key concept that cannot be overstated. Products not only have to be manufactured but also available 'just in time' – in every corner of the world. And at Jauch Quartz we do a lot to make sure that happens.

In Europe, with Jauch Quartz Germany and Jauch Quartz France, we have our own distribution centers for important markets. And in the US, Jauch Quartz America maintains our continuous presence in the North and South American markets.

A comprehensive network of distribution bases all over the world is ready to supply customers worldwide with Jauch-quality quartz crystals. Because we don't regard our products as mere components that are bought and forgotten: what's important to us is a sustainable relationship with the customer, from careful consulting before a decision to order processing, logistics and long-term field observation. We've noticed again and again that Jauch Quartz customers are customers who stay with us. Because they know what they're getting – wherever they happen to be.



FINDING SOLUTIONS...

...AND IMPLEMENTING THEM

At Jauch Quartz, customer satisfaction is not just an empty phrase, but a living reality. Delivery reliability is a proven fact at Jauch Quartz. Constant deliveries to renowned customers the world over prove that relying on Jauch Quartz means relying on production security. Because for us, overall product quality has always entailed a great deal more than just the product alone. With our Customer Support Center we offer active cooperation in any situation. Even in the concept phase of a development, it's worth discussing an optimal solution with us.

Or do you need a few hundred or a few thousand quartz crystals for your pilot run? We're the quartz specialists, so for us that's part of customer care. It's something that our customers have grown to appreciate.

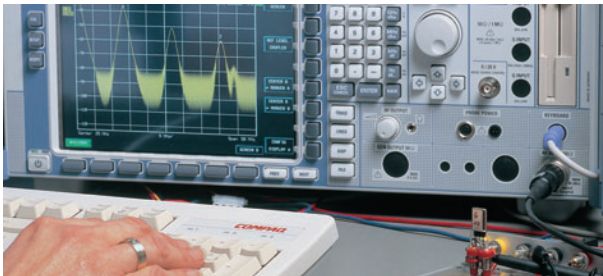

*Safety from high-quality measuring technology:
Special measuring systems, e.g. for analyzing the
frequency spectrum and noise conditions, guarantee that
our customers can rely one hundred percent on the
parameters set.*



*Application service via know-how:
Our development and service department supports our
customers in all questions of circuit design and – on
request – takes a closer look at application
scenarios.*



*Technical service from specialists:
At Jauch, developers find competent contacts
who support them in switch design just as
much as with special measuring technology
requirements.*



B.C.E. s.r.l.
Via Regina Pacis, 54/c - 41049 SASSUOLO (MO) Italy
Tel. +39 0536 811.616 r.a. - Fax +39 0536 811.500
www.bce.it - E-mail: bce@bce.it





- Our own quartz product **development center**
- **Consulting and care** by specialists for quartz products
- **Check-up service:** switching tests with special test devices
- **Fast service** with programmable oscillators for pilot runs and with quartz products in standard frequencies

THE SPECIALIST FOR FREQUENCY CONTROL PRODUCTS

- **Worldwide presence**
- **High availability** for standard frequencies, with over 20 million components off the shelf



PRODUCTION WORLDWIDE...

...FOR WORLD-FAMOUS BRANDS

Jauch – the world brand for quartz technology. With our own production facilities, we're present in important electronics centers all over the globe. And everywhere we are bound to the same basic principles: high efficiency, reliable delivery, value for money, and highest quality. Because we know how exacting our customers are. And we also know why.

International production,
guaranteed by
universal quality standards

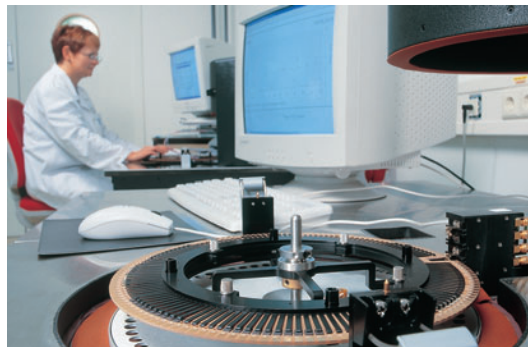

From raw quartz crystal production to special short runs to mass production in the millions in ever-constant quality, Jauch Quartz has a lot of performance to offer – and that applies just as much to large groups of companies as to smaller specialists. High flexibility in product design and production amounts enables us to cover a broad customer and business spectrum and thus maintain our independence.



Technology that makes quality possible: Ultrasound purification of quartz blanks for perfect surfaces.

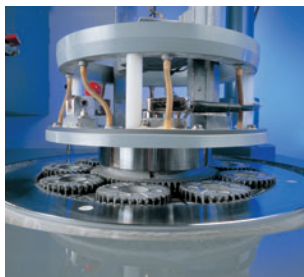

*Grinding of quartz blanks:
The right surface for the right clock rate.*



Jauch has production facilities at many locations around the world – from Europe to Asia. However different the people at these sites are, they all have one thing in common: they all work according to the same system of values. They all belong to the same corporate culture. That is the only way to produce on different continents and retain a uniform standard. Because wherever Jauch products are on the pulse of progress, the rhythm has to be just right.



B.C.E.
ELECTRONICS
Importation & Distribution
Electronic Components

B.C.E. s.r.l.
Via Regina Pacis, 54/c - 41049 SASSUOLO (MO) Italy
Tel. +39 0536 811.616 r.a. - Fax +39 0536 811.500
www.bce.it - E-mail: bce@bce.it





*The entire quartz crystal
processing chain:
from raw quartz production...*

*...component production using
semi- or fully-automatic production
technology depending on the run size...*

*...to series-oriented quality
assurance and automated
100-percent testing.*

B.C.E.
ELECTRONICS
Importation & Distribution
Electronic Components

B.C.E. s.r.l.
Via Regina Pacis, 54/c - 41049 SASSUOLO (MO) Italy
Tel. +39 0536 811.616 r.a. - Fax +39 0536 811.500
www.bce.it - E-mail: bce@bce.it



Certificate DIN EN ISO 9001:2000

SGS

Certificate DE05/53347

The management system of

JAUCH QUARTZ GmbH
In der Lache 24
DE-78056 VS-Schwenningen

has been assessed and certified as meeting the requirements of

ISO 9001:2000

For the following activities

**Design, production and sales of crystals,
oscillators, resonators and filters
Sales of batteries**

Further clarifications regarding the scope of this certificate and the applicability of ISO 9001:2000 requirements may be obtained by consulting the organization

This certificate is valid from 6th April 2005 until 5th April 2008
Issue 3. Certified since November 1998

Authorised by

Board of Directors

Certification body



SGS-ICS Gesellschaft für Zertifizierungen m.b.H. und Umweltgutachter
Raboisen 28 20095 Hamburg Germany
t +49 (0)40 30-101-361 f +49 (0)40 33-04-08 www.sgs.com

Page 1 of 1



graphic design: stähler regner photo: printed by: wahl (broad) security printing ltd. wiesbaden



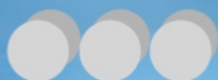

B.C.E. S.r.l. - Via Regina Pacis, 54/c - I 41049 Sassuolo (MO), Italy

Tel: (+39) 0536 811616 Fax: (+39) 0536 811500 E-mail: bce@bce.it Web: www.bce.it

