

FREQUENCY CONTROL PRODUCTS

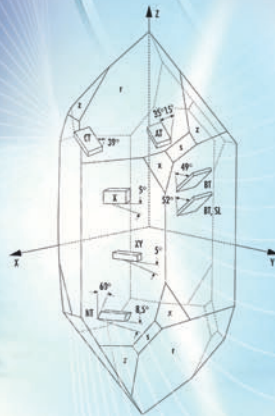

JAUCH AUTOMOTIVE CRYSTALS

individual working copy

03/11/14

THE SPECIALIST FOR FREQUENCY CONTROL PRODUCTS



The Specialist
for frequency control products

Worldwide Presence
expert advice by
quartz crystal specialists

Technical Customer Support
by field application engineers



Standard and Customized
quartz crystal products

High Product Availability
with over 28 million
components in stock

Flexibility and Reliability
by our own international
production facilities

www.jauch.de
www.jauch.fr
www.jauchusa.com
www.jauch.co.uk



SMD - JXG Series	Type	Frequency range	Size	PDF	Information
JXG12P4	4 Pad Version	13.0 - 50.0 MHz	3.2 x 2.5 x 1.0 mm		<ul style="list-style-type: none"> automotive temperature range available high mechanical reliability type available glass sealing contains small amount of Pb in accordance with RoHS directive exemption No 7
JXG13P4	4 Pad Version	8.0 - 60.0 MHz	5.0 x 3.2 x 1.5 mm		<ul style="list-style-type: none"> automotive temperature range available high mechanical reliability type available glass sealing contains small amount of Pb in accordance with RoHS directive exemption No 7
JXG15P2	2 Pad Version preferred type	8.0 - 60.0 MHz	5.0 x 3.2 x 1.5 mm		<ul style="list-style-type: none"> automotive temperature range available
JXG17P4	4 Pad Version	5.0 - 70.0 MHz	7.0 x 5.0 x 1.8 mm		
JXG17P2	2 Pad Version preferred type	5.0 - 70.0 MHz	7.0 x 5.0 x 1.8 mm		
JXG18P2	2 Pad Version	6.0 - 60.0 MHz	8.0 x 4.5 x 1.4 mm		

THE SPECIALIST FOR FREQUENCY CONTROL PRODUCTS

Index

JXS32P4 4 Pad Version	4
JXS53P4 4 Pad Version	6
JXG32P4 4 Pad Version	8
JXG53P2 2 Pad Version	10
JXG53P4 4 Pad Version	12
JXG75P2 2 Pad Version	14
JXG75P4 4 Pad Version	16
SMU2	18
SMU3	20
JTX310	22





actual size

Automotive SMD Crystal · JXS32P4

4 Pad Version · 3.2 x 2.5 mm

- seam sealed ceramic/metal package
- all versions are AEC-Q200 qualified
- HMR version with extended shock & vibration immunity
- reflow soldering temperature: 260 °C max.



General Data

type	JXS32P4
frequency range	10.0 ~ 54.0 MHz (fund. AT-cut)
frequency tolerance at 25 °C	± 10 ppm, ± 30 ppm, ± 50 ppm
load capacitance C_L	12 pF standard (option: 10 pF ~ 30.0 pF / series)
shunt capacitance C_0	< 5 pF
storage temperature	-40 °C ~ +125 °C
shock resistance	> 100 g (half sine pulse, 6.0 ms)*
drive level max.	100 µW (10 µW recommended)
aging	< ± 3 ppm first year

* optional HMR version: 3000G / half sine pulse / 0.3 ms

ESR (series resistance R_s) at max. temp. range

frequency in MHz	vibration mode	ESR max. in Ω	ESR typ. in Ω
10.0 ~ 11.999	fund.-AT	300	150
12.0 ~ 12.999	fund.-AT	100	50
13.0 ~ 15.999	fund.-AT	100	40
16.0 ~ 18.999	fund.-AT	80	40
19.0 ~ 21.999	fund.-AT	70	30
22.0 ~ 29.999	fund.-AT	70	25
30.0 ~ 54.000	fund.-AT	50	20

Frequency Stability vs. Temperature

		± 15 ppm	± 20 ppm	± 30 ppm	± 50 ppm	± 100 ppm
-20 °C ~ +70 °C	STD.	○*	○	○	○	○
-30 °C ~ +85 °C	T (-30/+85)	□				
-40 °C ~ +85 °C	T1	◇	○	○*	○	○
-40 °C ~ +105 °C	T2				○	○
-40 °C ~ +125 °C	T3				○	○

○ available ◇ for frequencies > 20 MHz, ask if available < 20 MHz □ for frequencies < 20 MHz
* best value for frequencies < 12.0 MHz

Marking

frequency with load capacitance code
company code / date code / internal code

date code: year/month
example: 2A = 2012 January

Jan.	Febr.	Mar.	Apr.	May	June
A	B	C	D	E	F

July	Aug.	Sept.	Oct.	Nov.	Dec.
G	H	J	K	L	M

Dimensions

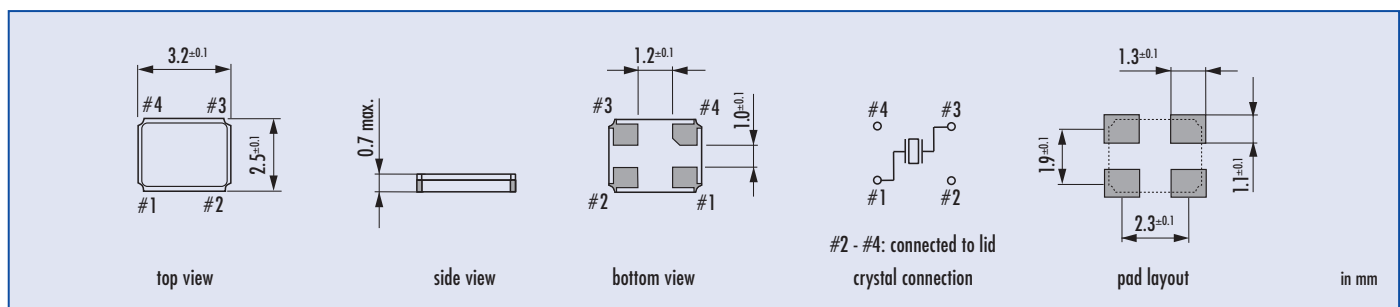

Order Information

Q	frequency	type	load capacitance	stability at 25 °C	stability vs. temp. range	option 1	option 2
Quartz	10.0 ~ 54.0 MHz	JXS32P4	12 pF standard 10 pF ~ 30 pF S for series	10 = ± 10 ppm 30 = ± 30 ppm 50 = ± 50 ppm	15 = ± 15 ppm 20 = ± 20 ppm 30 = ± 30 ppm 50 = ± 50 ppm 100 = ± 100 ppm	blank = -20 °C ~ +70 °C T (-30/+85) = -30 °C ~ +85 °C T1 = -40 °C ~ +85 °C T2 = -40 °C ~ +105 °C T3 = -40 °C ~ +125 °C FU = for fundamental frequencies ≥ 20 MHz	AEC = AEC-Q200 qualified HMR = high mechanical reliability (3000g/half sine wave/0.3ms)

Example: Q 28.0-JXS32P4-12-30/30-FU-AEC-LF (Suffix LF = RoHS compliant / Pb free pads)



Automotive SMD Crystal · JXS32P4

Taping Specification

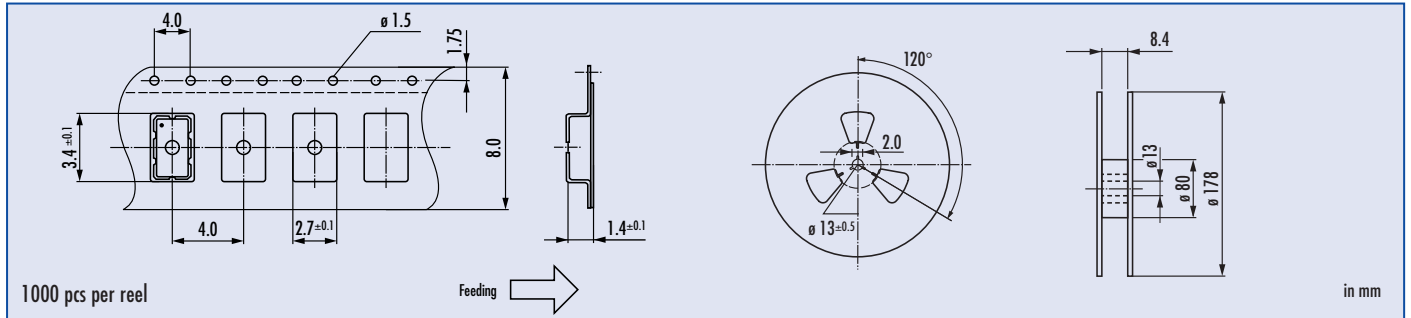

Reflow Soldering Profile

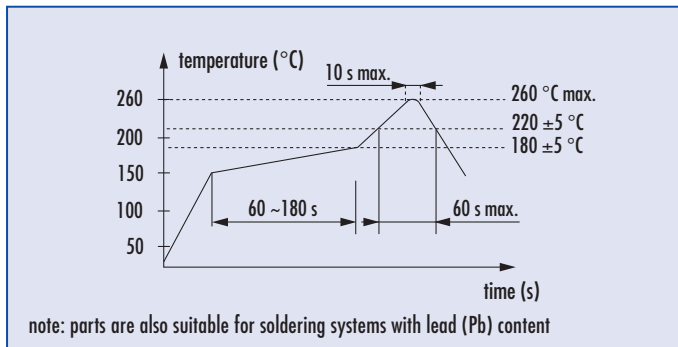

Load Capacitance Codes

8 pF: k	14 pF: x	22 pF: g	series: s
9 pF: n	15 pF: j	24 pF: d	T: 3rd OT
10 pF: h	16 pF: b	25 pF: r	
11 pF: l	17 pF: t	27 pF: w	
12 pF: a	18 pF: f	30 pF: .	
13 pF: v	20 pF: c		

example 20.0 MHz / 12 pF: 20a00





actual size

Automotive SMD Crystal · JXS53P4

4 Pad Version · 5.0 x 3.2 mm

- seam sealed ceramic/metal package
- all versions are AEC-Q200 qualified
- HMR version with extended shock & vibration immunity
- reflow soldering temperature: 260 °C max.



General Data

type	JXS53P4
frequency range	8.0 ~ 56.0 MHz (fund. AT-cut)
frequency tolerance at 25 °C	± 10 ppm, ± 30 ppm, ± 50 ppm
load capacitance C_L	12 pF standard (option: 8 pF ~ 30.0 pF / series)
shunt capacitance C_0	< 7 pF
storage temperature	-40 °C ~ +125 °C
shock resistance	> 100 g (half sine pulse, 6.0 ms)*
drive level max.	100 µW (10 µW recommended)
aging	< ± 3 ppm first year

* optional HMR version: 3000G / half sine pulse / 0.3 ms

ESR (series resistance R_s) at max. temp. range

frequency in MHz	vibration mode	ESR max. in Ω	ESR typ. in Ω
8.0 ~ 9.999	fund.-AT	100	50
10.0 ~ 10.999	fund.-AT	50	30
11.0 ~ 11.999	fund.-AT	40	25
12.0 ~ 21.999	fund.-AT	40	20
22.0 ~ 24.999	fund.-AT	40	15
25.0 ~ 49.999	fund.-AT	30	15
50.0 ~ 56.000	fund.-AT	40	20

Frequency Stability vs. Temperature

		± 15 ppm	± 20 ppm	± 30 ppm	± 50 ppm	± 100 ppm
-20 °C ~ +70 °C	STD.	○	○	○	○	○
-40 °C ~ +85 °C	T1	○	○	○	○	○
-40 °C ~ +105 °C	T2				○	○
-40 °C ~ +125 °C	T3					○

○ available

Marking

frequency with load capacitance code
company code / date code / internal code

date code: year/month
example: 2A = 2012 January

Jan.	Febr.	Mar.	Apr.	May	June
A	B	C	D	E	F

July	Aug.	Sept.	Oct.	Nov.	Dec.
G	H	J	K	L	M

Dimensions

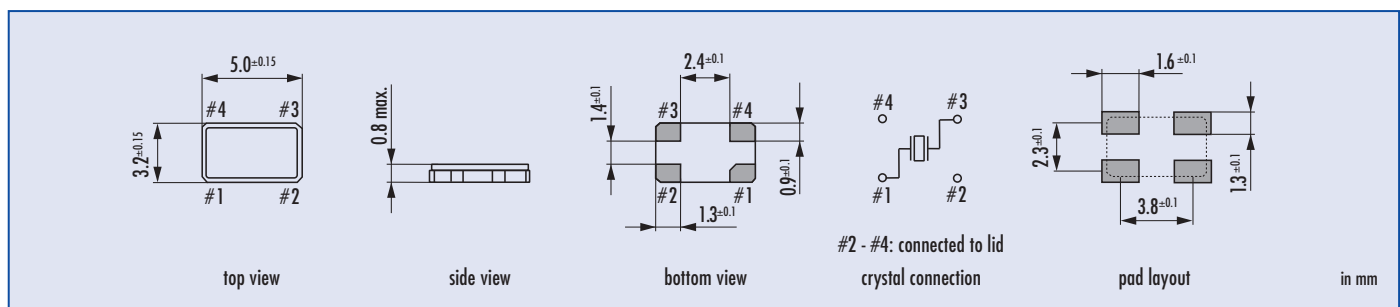

Order Information

Q	frequency	type	load capacitance	stability at 25 °C	stability vs. temp. range	option 1	option 2
Quartz	8.0 ~ 56.0 MHz	JXS53P4	12 pF standard 8 pF ~ 30 pF S for series	10 = ± 10 ppm 30 = ± 30 ppm 50 = ± 50 ppm	15 = ± 15 ppm 20 = ± 20 ppm 30 = ± 30 ppm 50 = ± 50 ppm 100 = ± 100 ppm	blank = -20 °C ~ +70 °C T1 = -40 °C ~ +85 °C T2 = -40 °C ~ +105 °C T3 = -40 °C ~ +125 °C FU = for fundamental frequencies ≥ 20 MHz	AEC = AEC-Q200 qualified HMR = high mechanical reliability (3000g/half sine wave/0.3ms)

Example: Q 30.0-JXS53P4-12-30/50-FU-AEC-LF (Suffix LF = RoHS compliant / Pb free pads)



Automotive SMD Crystal · JXS53P4

Taping Specification

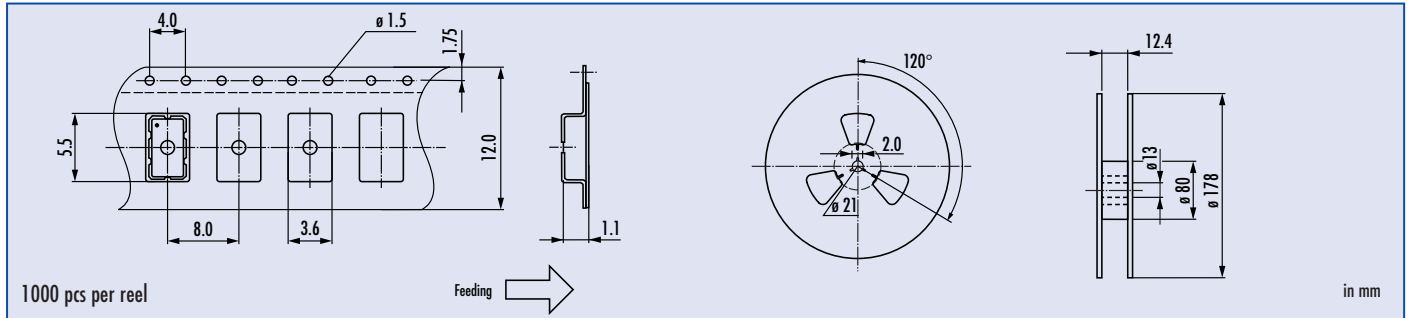

Reflow Soldering Profile

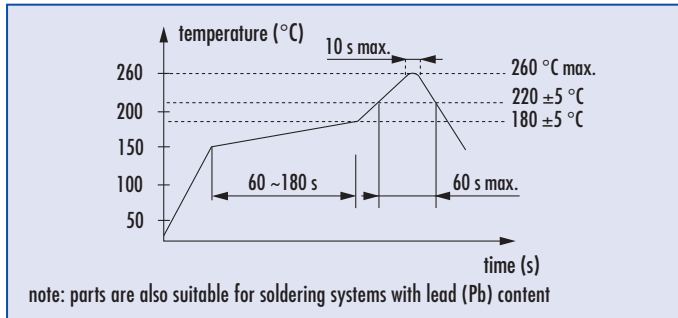

Load Capacitance Codes

8 pF: k	14 pF: x	22 pF: g	series: s
9 pF: n	15 pF: j	24 pF: d	T: 3rd OT
10 pF: h	16 pF: b	25 pF: r	
11 pF: l	17 pF: t	27 pF: w	
12 pF: a	18 pF: f	30 pF: .	
13 pF: v	20 pF: c		

example 20.0 MHz / 12 pF: 20a00





actual size

Automotive SMD Crystal · JXG32P4

4 Pad Version · 3.2 x 2.5 mm

- glass sealed ceramic package
- all versions are AEC-Q200 qualified
- HMR version with extended shock & vibration immunity
- RKE version withstands 100x drop test from 150 cm



General Data

type	JXG32P4
frequency range	12.0 ~ 50.0 MHz (fund. AT-cut) ask for availability of lower frequencies
frequency stability at 25 °C	± 30 ppm, ± 50 ppm
load capacitance C _L	12 pF standard (option: 10 pF ~ 30.0 pF / series)
shunt capacitance C ₀	< 7 pF
storage temperature	-40 °C ~ +125 °C
shock resistance	> 100 g (half sine pulse, 6.0 ms)*
drive level max.	100 µW (10 µW recommended)
aging	< ± 3 ppm first year

* optional HMR version: 3000G / half sine pulse / 0.3 ms

ESR (series resistance R_s)

frequency in MHz	vibration mode	ESR max. in Ω	ESR typ. in Ω
12.0 ~ 12.999	fund.-AT	200	90
13.0 ~ 13.999	fund.-AT	150	70
14.0 ~ 15.999	fund.-AT	100	40
16.0 ~ 18.999	fund.-AT	80	35
19.0 ~ 21.999	fund.-AT	70	30
22.0 ~ 29.999	fund.-AT	70	25
30.0 ~ 50.000	fund.-AT	50	20

Frequency Stability vs. Temperature

		± 30 ppm	± 50 ppm	± 100 ppm		
-20 °C ~ +70 °C	STD.	○	○	○		
-40 °C ~ +85 °C	T1	○	○	○		
-40 °C ~ +105 °C	T2		○	○		
-40 °C ~ +125 °C	T3			○		

○ available

Marking

frequency with load capacitance code
company code / date code / internal code

date code: year/month
example: 2A = 2012 January

Jan.	Febr.	Mar.	Apr.	May	June
A	B	C	D	E	F

July	Aug.	Sept.	Oct.	Nov.	Dec.
G	H	J	K	L	M

Dimensions

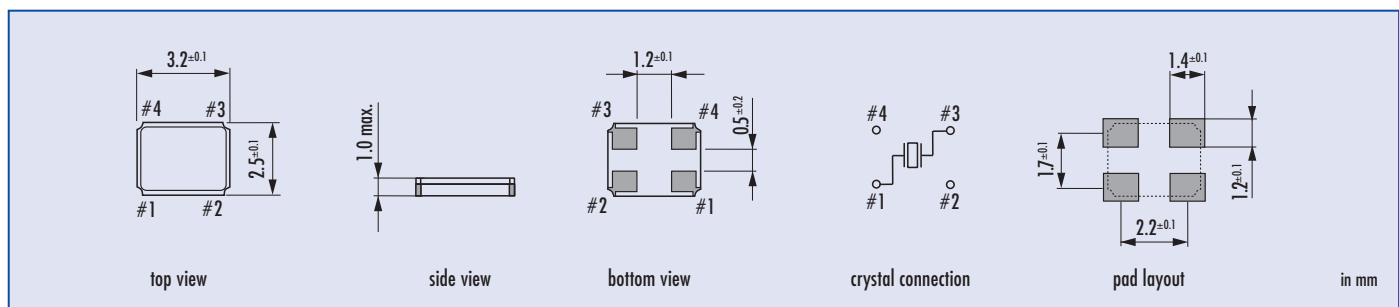

Order Information

Q	frequency	type	load capacitance	stability at 25 °C	stability vs. temp. range	option 1	option 2
Quartz	12.0 ~ 50.0 MHz	JXG32P4	12 pF standard 10 pF ~ 30 pF S for series	30 = ± 30 ppm 50 = ± 50 ppm	30 = ± 30 ppm 50 = ± 50 ppm 100 = ± 100 ppm	blank = -20 °C ~ +70 °C T1 = -40 °C ~ +85 °C T2 = -40 °C ~ +105 °C T3 = -40 °C ~ +125 °C FU = for fundamental frequencies ≥ 20 MHz	AEC = AEC-Q200 qualified HMR = high mechanical reliability (3000g/half sine wave/0.3ms) RKE = for remote keyless entry (drop 100x / 150 cm)

Example: Q 28.0-JXG32P4-12-30/30-T1-FU-AEC-LF (Suffix LF = RoHS compliant / Pb free pads)



Automotive SMD Crystal · JXG32P4

Taping Specification

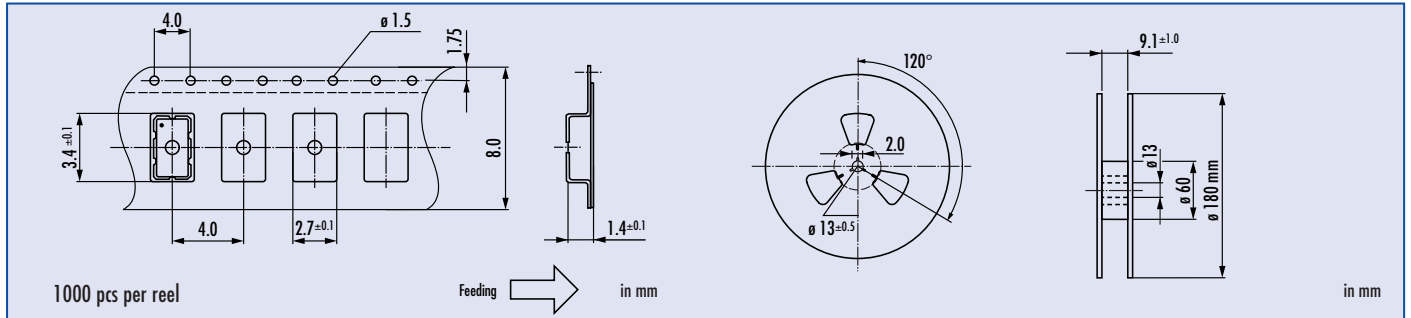

Reflow Soldering Profile

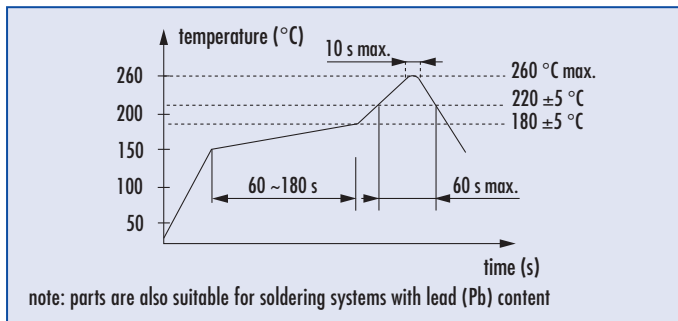

Load Capacitance Codes

8 pF: k	14 pF: x	22 pF: g	series: s
9 pF: n	15 pF: j	24 pF: d	T: 3rd OT
10 pF: h	16 pF: b	25 pF: r	
11 pF: l	17 pF: t	27 pF: w	
12 pF: a	18 pF: f	30 pF: .	
13 pF: v	20 pF: c		

example 20.0 MHz / 12 pF: 20a00





actual size

Automotive SMD Crystal · JXG53P2

2 Pad Version · 5.0 x 3.2 mm

- glass sealed ceramic package
- all versions are AEC-Q200 qualified
- HMR version with extended shock & vibration immunity
- RKE version withstands 100x drop test from 150 cm



General Data

type	JXG53P2
frequency range	8.0 ~ 50.0 MHz (fund. AT-cut) ask for availability of lower frequencies 45.0 ~ 60.0 MHz (3rd OT AT-cut)
frequency stability at 25 °C	± 30 ppm, ± 50 ppm
load capacitance C_L	12 pF standard (option: 10 pF ~ 30.0 pF / series)
shunt capacitance C_0	< 7 pF
storage temperature	-40 °C ~ +125 °C
shock resistance	> 100 g (half sine pulse, 6.0 ms)*
drive level max.	100 µW (10 µW recommended)
aging	< ± 3 ppm first year

* optional HMR version: 3000G / half sine pulse / 0.3 ms

ESR (series resistance R_s)

frequency in MHz	vibration mode	ESR max. in Ω	ESR typ. in Ω
8.0 ~ 8.999	fund.-AT	300	120
9.0 ~ 9.999	fund.-AT	250	100
10.0 ~ 11.999	fund.-AT	60	35
12.0 ~ 15.999	fund.-AT	60	25
16.0 ~ 21.999	fund.-AT	50	20
22.0 ~ 24.999	fund.-AT	40	20
25.0 ~ 50.000	fund.-AT	30	20
45.0 ~ 60.000	3rd OT-AT	90	65

Frequency Stability vs. Temperature

		± 30 ppm	± 50 ppm	± 100 ppm		
-20 °C ~ +70 °C	STD.	○	○	○		
-40 °C ~ +85 °C	T1	○	○	○		
-40 °C ~ +105 °C	T2		○	○		
-40 °C ~ +125 °C	T3			○		

○ available

Marking

frequency with load capacitance code
company code / date code / internal code

date code: year/month
example: 2A = 2012 January

Jan.	Febr.	Mar.	Apr.	May	June
A	B	C	D	E	F

July	Aug.	Sept.	Oct.	Nov.	Dec.
G	H	J	K	L	M

Dimensions

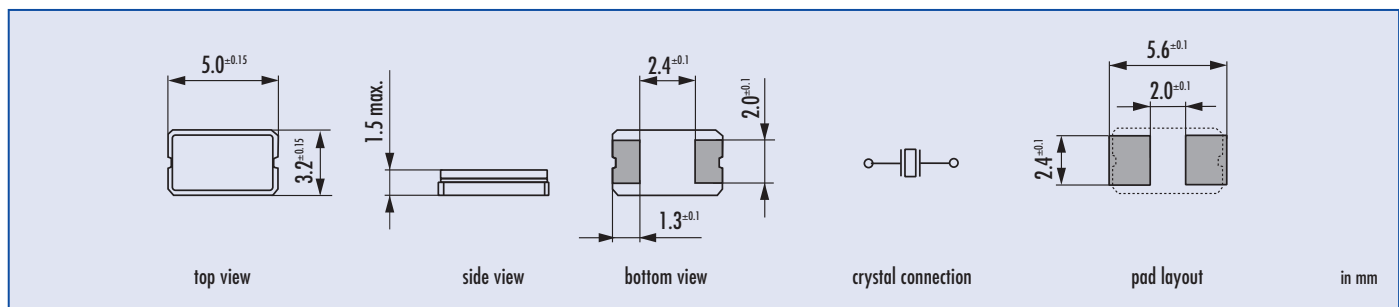

Order Information

Q	frequency	type	load capacitance	stability at 25 °C	stability vs. temp. range	option 1	option 2
Quartz	8.0 ~ 60.0 MHz	JXG53P2	12 pF standard 10 pF ~ 30 pF S for series	30 = ± 30 ppm 50 = ± 50 ppm	30 = ± 30 ppm 50 = ± 50 ppm 100 = ± 100 ppm	blank = -20 °C ~ +70 °C T1 = -40 °C ~ +85 °C T2 = -40 °C ~ +105 °C T3 = -40 °C ~ +125 °C FU = for fundamental frequencies ≥ 20 MHz 30T = 3rd overtone	AEC = AEC-Q200 qualified HMR = high mechanical reliability (3000g/half sine wave/0.3ms) RKE = for remote keyless entry (drop 100x / 150 cm)

Example: Q 28.0-JXG53P2-12-30/30-T1-FU-AEC-LF (Suffix LF = RoHS compliant / Pb free pads)



Automotive SMD Crystal · JXG53P2

Taping Specification

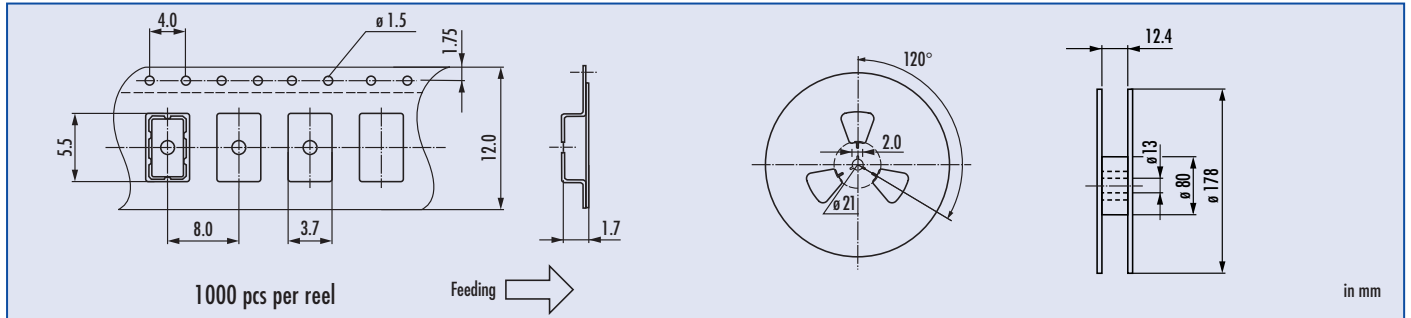

Reflow Soldering Profile

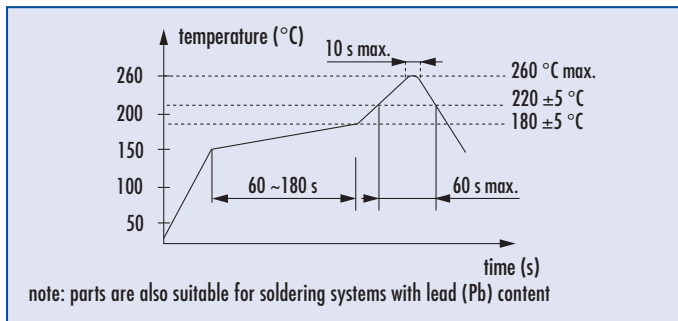

Load Capacitance Codes

8 pF: k	14 pF: x	22 pF: g	series: s
9 pF: n	15 pF: j	24 pF: d	T: 3rd OT
10 pF: h	16 pF: b	25 pF: r	
11 pF: l	17 pF: t	27 pF: w	
12 pF: a	18 pF: f	30 pF: .	
13 pF: v	20 pF: c		

example 12.0 MHz / 12 pF: 12a00





actual size

Automotive SMD Crystal · JXG53P4

4 Pad Version · 5.0 x 3.2 mm

- glass sealed ceramic package
- all versions are AEC-Q200 qualified
- HMR version with extended shock & vibration immunity
- RKE version withstands 100x drop test from 150 cm



General Data

type	JXG53P4
frequency range	8.0 ~ 50.0 MHz (fund. AT-cut) ask for availability of lower frequencies 45.0 ~ 60.0 MHz (3rd OT AT-cut)
frequency stability at 25 °C	± 30 ppm, ± 50 ppm
load capacitance C_L	12 pF standard (option: 10 pF ~ 30.0 pF / series)
shunt capacitance C_0	< 7 pF
storage temperature	-40 °C ~ +125 °C
shock resistance	> 100 g (half sine pulse, 6.0 ms)*
drive level max.	100 μ W (10 μ W recommended)
aging	< ± 3 ppm first year

* optional HMR version: 3000G / half sine pulse / 0.3 ms

ESR (series resistance R_s)

frequency in MHz	vibration mode	ESR max. in Ω	ESR typ. in Ω
8.0 ~ 8.999	fund.-AT	300	120
9.0 ~ 9.999	fund.-AT	250	100
10.0 ~ 11.999	fund.-AT	60	35
12.0 ~ 15.999	fund.-AT	60	25
16.0 ~ 21.999	fund.-AT	50	20
22.0 ~ 24.999	fund.-AT	40	20
25.0 ~ 50.000	fund.-AT	30	20
45.0 ~ 60.000	3rd OT-AT	90	65

Frequency Stability vs. Temperature

Temperature Range	Grade	± 30 ppm	± 50 ppm	± 100 ppm
-20 °C ~ +70 °C	STD.	○	○	○
-40 °C ~ +85 °C	T1	○	○	○
-40 °C ~ +105 °C	T2		○	○
-40 °C ~ +125 °C	T3			○

○ available

Marking

frequency with load capacitance code
company code / date code / internal code

date code: year/month
example: 2A = 2012 January

Jan.	Febr.	Mar.	Apr.	May	June
A	B	C	D	E	F

July	Aug.	Sept.	Oct.	Nov.	Dec.
G	H	J	K	L	M

Dimensions

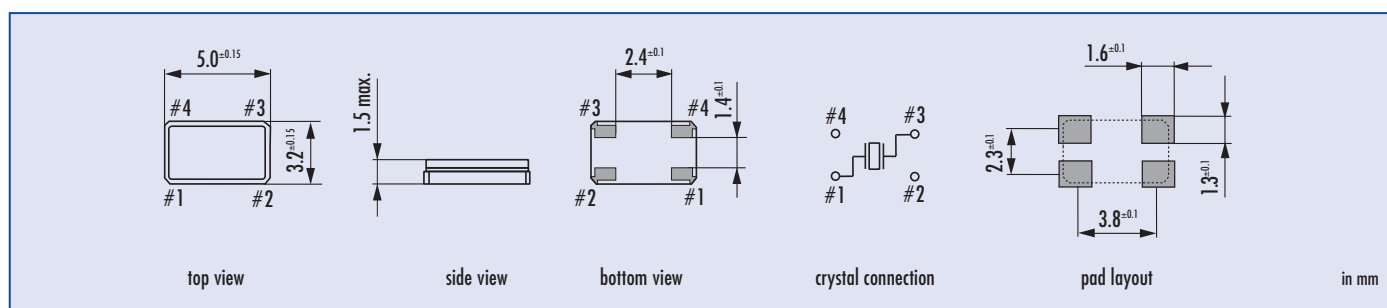

Order Information

Q	frequency	type	load capacitance	stability at 25 °C	stability vs. temp. range	option 1	option 2
Quartz	8.0 ~ 60.0 MHz	JXG53P4	12 pF standard 10 pF ~ 30 pF S for series	30 = ± 30 ppm 50 = ± 50 ppm	30 = ± 30 ppm 50 = ± 50 ppm 100 = ± 100 ppm	blank = -20 °C ~ +70 °C T1 = -40 °C ~ +85 °C T2 = -40 °C ~ +105 °C T3 = -40 °C ~ +125 °C FU = for fundamental frequencies ≥ 20 MHz 30T = 3rd overtone	AEC = AEC-Q200 qualified HMR = high mechanical reliability (3000g/half sine wave/0.3ms) RKE = for remote keyless entry (drop 100x / 150 cm)

Example: Q 28.0-JXG53P4-12-30/30-T1-FU-AEC-LF (Suffix LF = RoHS compliant / Pb free pads)



Automotive SMD Crystal · JXG53P4

Taping Specification

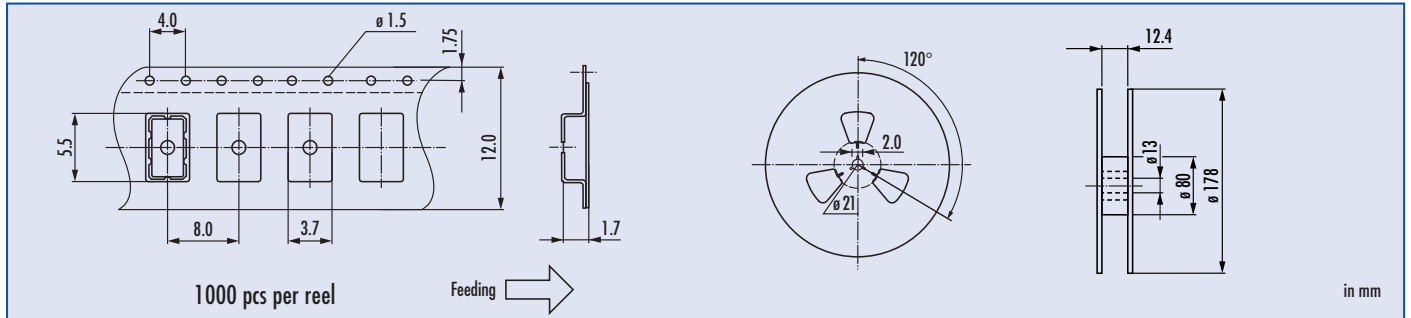

Reflow Soldering Profile

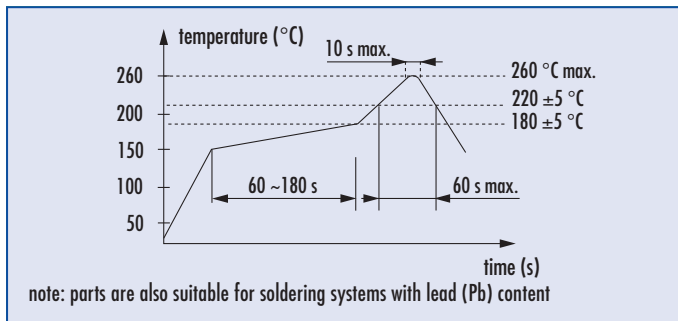

Load Capacitance Codes

8 pF: k	14 pF: x	22 pF: g	series: s
9 pF: n	15 pF: j	24 pF: d	T: 3rd OT
10 pF: h	16 pF: b	25 pF: r	
11 pF: l	17 pF: t	27 pF: w	
12 pF: a	18 pF: f	30 pF: .	
13 pF: v	20 pF: c		

example 12.0 MHz / 12 pF: 12a00





actual size

Automotive SMD Crystal · JXG75P2

2 Pad Version · 7.0 x 5.0 mm

- glass sealed ceramic package
- all versions are AEC-Q200 qualified
- HMR version with extended shock & vibration immunity
- RKE version withstands 100x drop test from 150 cm



General Data

type	JXG75P2
frequency range	5.0 ~ 50.0 MHz (fund. AT-cut)
	30.0 ~ 70.0 MHz (3rd OT AT-cut)
frequency stability at 25 °C	± 30 ppm, ± 50 ppm
load capacitance C _L	12 pF standard (option: 10 pF ~ 30.0 pF / series)
shunt capacitance C ₀	< 7 pF
storage temperature	-40 °C ~ +125 °C
shock resistance	> 100 g (half sine pulse, 6.0 ms)*
drive level max.	100 µW (10 µW recommended)
aging	< ± 3 ppm first year

* optional HMR version: 3000G / half sine pulse / 0.3 ms

ESR (series resistance R_s)

frequency in MHz	vibration mode	ESR max. in Ω	ESR typ. in Ω
5.0 ~ 5.999	fund.-AT	200	130
6.0 ~ 6.999	fund.-AT	100	70
7.0 ~ 9.999	fund.-AT	80	35
10.0 ~ 15.999	fund.-AT	60	25
16.0 ~ 21.999	fund.-AT	50	20
22.0 ~ 24.999	fund.-AT	40	20
25.0 ~ 50.000	fund.-AT	30	15
30.0 ~ 44.999	3rd OT-AT	80	60
45.0 ~ 70.000	3rd OT-AT	70	55

Frequency Stability vs. Temperature

		± 30 ppm	± 50 ppm	± 100 ppm		
-20 °C ~ +70 °C	STD.	○	○	○		
-40 °C ~ +85 °C	T1	○	○	○		
-40 °C ~ +105 °C	T2		○	○		
-40 °C ~ +125 °C	T3			○		

○ available

Marking

frequency with load capacitance code
company code / date code / internal code

date code: year/month
example: 2A = 2012 January

Jan.	Febr.	Mar.	Apr.	May	June
A	B	C	D	E	F

July	Aug.	Sept.	Oct.	Nov.	Dec.
G	H	J	K	L	M

Dimensions

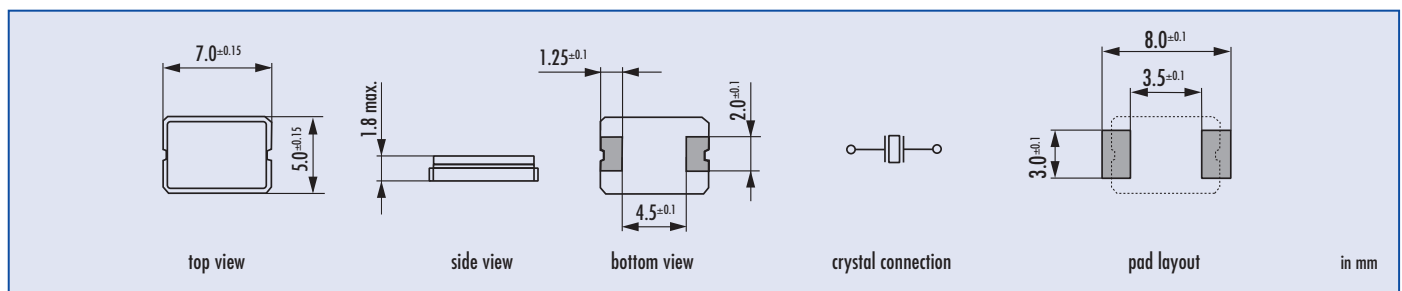

Order Information

Q	frequency	type	load capacitance	stability at 25 °C	stability vs. temp. range	option 1	option 2
Quartz	5.0 ~ 70.0 MHz	JXG75P2	12 pF standard 10 pF ~ 30 pF S for series	30 = ± 30 ppm 50 = ± 50 ppm	30 = ± 30 ppm 50 = ± 50 ppm 100 = ± 100 ppm	blank = -20 °C ~ +70 °C T1 = -40 °C ~ +85 °C T2 = -40 °C ~ +105 °C T3 = -40 °C ~ +125 °C FU = for fundamental frequencies ≥ 20 MHz 30T = 3rd overtone	AEC = AEC-Q200 qualified HMR = high mechanical reliability (3000g/half sine wave/0.3ms) RKE = for remote keyless entry (drop 100x / 150 cm)

Example: Q 28.0-JXG75P2-12-30/30-T1-FU-AEC-LF (Suffix LF = RoHS compliant / Pb free pads)



Automotive SMD Crystal · JXG75P2

Taping Specification

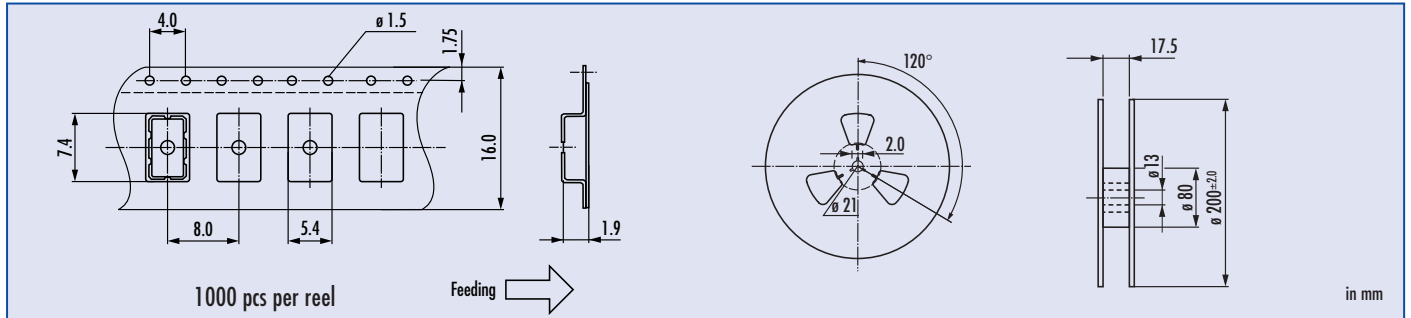

Reflow Soldering Profile

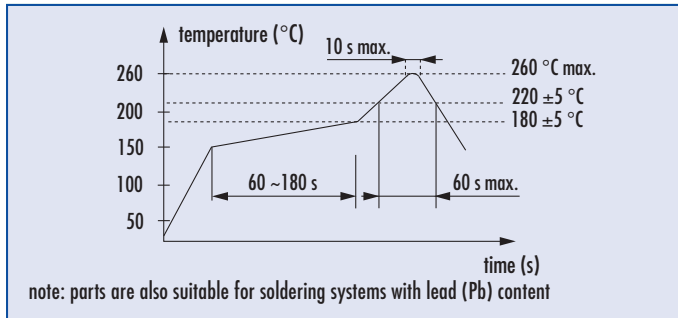

Load Capacitance Codes

8 pF: k	14 pF: x	22 pF: g	series: s
9 pF: n	15 pF: j	24 pF: d	T: 3rd OT
10 pF: h	16 pF: b	25 pF: r	
11 pF: l	17 pF: t	27 pF: w	
12 pF: a	18 pF: f	30 pF: .	
13 pF: v	20 pF: c		

example 8.0 MHz / 12 pF: 8a000





actual size

Automotive SMD Crystal · JXG75P4

4 Pad Version · 7.0 x 5.0 mm

- glass sealed ceramic package
- all versions are AEC-Q200 qualified
- HMR version with extended shock & vibration immunity
- RKE version withstands 100x drop test from 150 cm



General Data

type	JXG75P4
frequency range	5.0 ~ 50.0 MHz (fund. AT-cut) 30.0 ~ 70.0 MHz (3rd OT AT-cut)
frequency stability at 25 °C	± 30 ppm, ± 50 ppm
load capacitance C_L	12 pF standard (option: 10 pF ~ 30.0 pF / series)
shunt capacitance C_0	< 7 pF
storage temperature	-40 °C ~ +125 °C
shock resistance	> 100 g (half sine pulse, 6.0 ms)*
drive level max.	100 μ W (10 μ W recommended)
aging	< ± 3 ppm first year

* optional HMR version: 3000G / half sine pulse / 0.3 ms

ESR (series resistance R_s)

frequency in MHz	vibration mode	ESR max. in Ω	ESR typ. in Ω
5.0 ~ 5.999	fund.-AT	200	130
6.0 ~ 6.999	fund.-AT	100	70
7.0 ~ 9.999	fund.-AT	80	35
10.0 ~ 15.999	fund.-AT	60	25
16.0 ~ 21.999	fund.-AT	50	20
22.0 ~ 24.999	fund.-AT	40	20
25.0 ~ 50.000	fund.-AT	30	15
30.0 ~ 44.999	3rd OT-AT	80	60
45.0 ~ 70.000	3rd OT-AT	70	55

Frequency Stability vs. Temperature

		± 30 ppm	± 50 ppm	± 100 ppm		
-20 °C ~ +70 °C	STD.	○	○	○		
-40 °C ~ +85 °C	T1	○	○	○		
-40 °C ~ +105 °C	T2		○	○		
-40 °C ~ +125 °C	T3			○		

○ available

Marking

frequency with load capacitance code
company code / date code / internal code

date code: year/month
example: 2A = 2012 January

Jan.	Febr.	Mar.	Apr.	May	June
A	B	C	D	E	F

July	Aug.	Sept.	Oct.	Nov.	Dec.
G	H	J	K	L	M

Dimensions

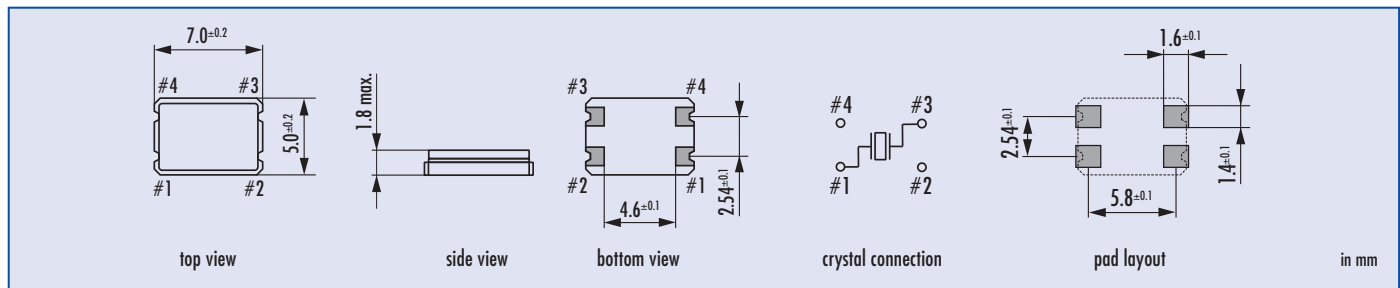

Order Information

Q	frequency	type	load capacitance	stability at 25 °C	stability vs. temp. range	option 1	option 2
Quartz	5.0 ~ 70.0 MHz	JXG75P4	12 pF standard 10 pF ~ 30 pF S for series	30 = ± 30 ppm 50 = ± 50 ppm	30 = ± 30 ppm 50 = ± 50 ppm 100 = ± 100 ppm	blank = -20 °C ~ +70 °C T1 = -40 °C ~ +85 °C T2 = -40 °C ~ +105 °C T3 = -40 °C ~ +125 °C FU = for fundamental frequencies ≥ 20 MHz 30T = 3rd overtone	AEC = AEC-Q200 qualified HMR = high mechanical reliability (3000g/half sine wave/0.3ms) RKE = for remote keyless entry (drop 100x / 150 cm)

Example: Q 28.0-JXG75P4-12-30/30-T1-FU-AEC-LF (Suffix LF = RoHS compliant / Pb free pads)



Automotive SMD Crystal · JXG75P4

Taping Specification

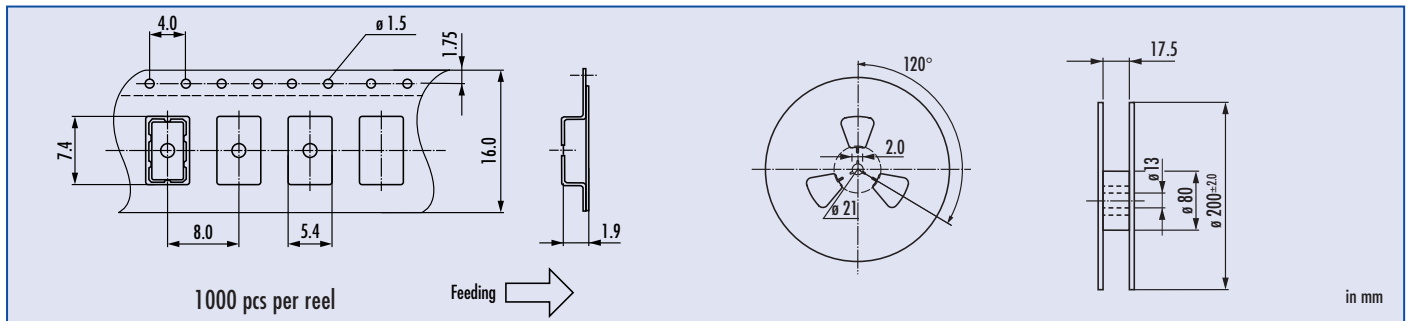

Reflow Soldering Profile

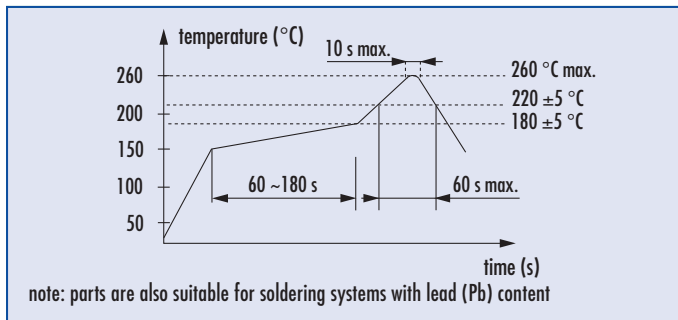

Load Capacitance Codes

8 pF: k	14 pF: x	22 pF: g	series: s
9 pF: n	15 pF: j	24 pF: d	T: 3rd OT
10 pF: h	16 pF: b	25 pF: r	
11 pF: l	17 pF: t	27 pF: w	
12 pF: a	18 pF: f	30 pF: .	
13 pF: v	20 pF: c		

example 8.0 MHz / 12 pF: 8a000





actual size

SMU2 · AEC-Q200

2 Pad Version · 11.5 x 4.8 mm

- AEC-Q200 qualified
- recommended for automotive applications
- reflow soldering temperature: 260 °C max.
- package height 3.0 mm max.



General Data

type	SMU2	
frequency range	4.0 ~ 33.0 MHz	(fund. AT-cut)
	27.0 ~ 60.0 MHz	(3rd OT AT-cut)
frequency tolerance at 25 °C	± 20 ppm / ± 30 ppm / ± 50 ppm	
load capacitance C _L	12 pF ~ 32 pF or series	
shunt capacitance C ₀	< 5 pF	
storage temperature	-40 °C ~ +125 °C	
shock resistance	> 100 g	(half sine pulse, 6.0 ms)
drive level max.	500 µW	(100 µW recommended)
aging	< ± 5 ppm first year	

ESR (series resistance R_s)

frequency in MHz	vibration mode	ESR max. in Ω	ESR typ. in Ω
4.0 ~ 5.999	fund.-AT	80	60
6.0 ~ 6.999	fund.-AT	70	35
7.0 ~ 7.999	fund.-AT	50	25
8.0 ~ 8.999	fund.-AT	50	25
9.0 ~ 13.999	fund.-AT	35	15
14.0 ~ 33.000	fund.-AT	30	10
27.0 ~ 60.000	3rd OT-AT	100	60

Frequency Stability vs. Temperature

		± 30 ppm	± 50 ppm	± 100 ppm	± 150 ppm
-20 °C ~ +70 °C	STD.	○	●		
-40 °C ~ +85 °C	T1	○	○	●	
-40 °C ~ +105 °C	T2		○	○	
-40 °C ~ +125 °C	T3				○

● standard
○ available

Marking

frequency with load capacitance code
company code / date code / internal code

	Jan.	Febr.	Mar.	Apr.	May	June	July	Aug.	Sept.	Oct.	Nov.	Dec.
2012	n	p	q	r	s	t	u	v	w	x	y	z
2013	A	B	C	D	E	F	G	H	J	K	L	M
2014	N	P	Q	R	S	T	U	V	W	X	Y	Z
2015	a	b	c	d	e	f	g	h	i	k	l	m

Dimensions

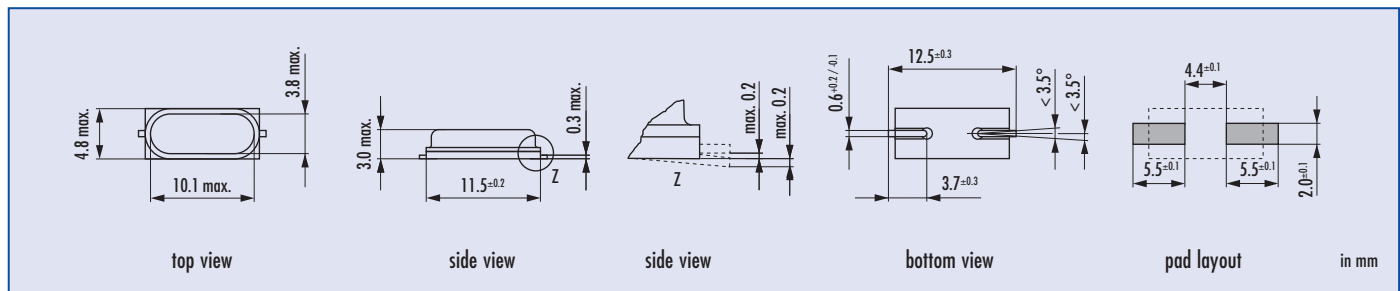

Order Information

Q	frequency	type	load capacitance	stability at 25 °C	stability vs. temp. range	option
Quartz	4.0 ~ 60.0 MHz	SMU2	12 pF ~ 32 pF S for series	20 = ± 20 ppm 30 = ± 30 ppm 50 = ± 50 ppm	30 = ± 30 ppm 50 = ± 50 ppm 100 = ± 100 ppm 150 = ± 150 ppm	blank = -20 °C ~ +70 °C T1 = -40 °C ~ +85 °C T2 = -40 °C ~ +105 °C T3 = -40 °C ~ +125 °C FU = for fundamental frequencies ≥ 20 MHz 30T = 3rd overtone AEC = AEC-Q200 qualified

Example: Q 25.0-SMU2-30-30/50-T2-FU-AEC-LF (Suffix LF = RoHS compliant / Pb free pins or pads)







actual size

SMU3 · AEC-Q200

2 Pad Version · 11.5 x 4.8 mm

- AEC-Q200 qualified
- recommended for automotive applications
- reflow soldering temperature: 260 °C max.
- package height 4.0 mm max.



General Data

type	SMU3	
frequency range	3.2768 ~ 33.0 MHz	(fund. AT-cut)
	27.0 ~ 60.0 MHz	(3rd OT AT-cut)
frequency tolerance at 25 °C	± 20 ppm / ± 30 ppm / ± 50 ppm	
load capacitance C_L	12 pF ~ 32 pF or series	
shunt capacitance C_0	< 5 pF	
storage temperature	-40 °C ~ +125 °C	
shock resistance	> 100 g	(half sine pulse, 6.0 ms)
drive level max.	300 µW	(100 µW recommended)
aging	< ± 5 ppm first year	

ESR (series resistance R_s)

frequency in MHz	vibration mode	ESR max. in Ω	ESR typ. in Ω
3.276 ~ 3.499	fund.-AT	200	100
3.579 ~ 3.999	fund.-AT	120	80
4.000 ~ 5.999	fund.-AT	80	60
6.000 ~ 6.999	fund.-AT	70	35
7.000 ~ 8.999	fund.-AT	50	25
9.000 ~ 13.99	fund.-AT	35	15
14.00 ~ 33.00	fund.-AT	30	10
27.00 ~ 60.00	3rd OT-AT	100	60

Frequency Stability vs. Temperature

		± 20 ppm	± 30 ppm	± 50 ppm	± 100 ppm	± 150 ppm
-20 °C ~ +70 °C	STD.	○	○	●		
-40 °C ~ +85 °C	T1			○	●	
-40 °C ~ +105 °C	T2			○	○	
-40 °C ~ +125 °C	T3					○

● standard
○ available

Marking

frequency with load capacitance code
company code / date code / internal code

	Jan.	Febr.	Mar.	Apr.	May	June	July	Aug.	Sept.	Oct.	Nov.	Dec.
2012	n	p	q	r	s	t	u	v	w	x	y	z
2013	A	B	C	D	E	F	G	H	J	K	L	M
2014	N	P	Q	R	S	T	U	V	W	X	Y	Z
2015	a	b	c	d	e	f	g	h	i	k	l	m

Dimensions

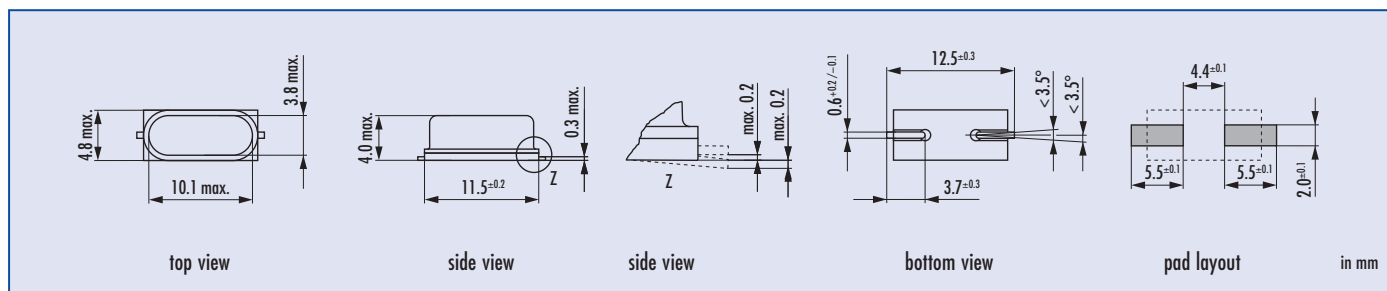

Order Information

Q	frequency	type	load capacitance	stability at 25 °C	stability vs. temp. range	option
Quartz	3.2768 ~ 60.0 MHz	SMU3	12 pF ~ 32 pF S for series	20 = ± 20 ppm 30 = ± 30 ppm 50 = ± 50 ppm	20 = ± 20 ppm 30 = ± 30 ppm 50 = ± 50 ppm 100 = ± 100 ppm 150 = ± 150 ppm	blank = -20 °C ~ +70 °C T1 = -40 °C ~ +85 °C T2 = -40 °C ~ +105 °C T3 = -40 °C ~ +125 °C FU = for fundamental frequencies ≥ 20 MHz 30T = 3rd overtone AEC = AEC-Q200 qualified

Example: Q 30.0-SMU3-30-30/50-T2-FU-AEC-LF (Suffix LF = RoHS compliant / Pb free pins or pads)



B.C.E. s.r.l.
Via Regina Pacis, 54/c - 41049 SASSUOLO (MO) Italy
Tel. +39 0536 811.616 r.a. - Fax +39 0536 811.500
www.bce.it - E-mail: bce@bce.it







actual size

Automotive SMD Crystal · JTX310

SMD Tuning Fork Crystal · 3.2 x 1.5 mm

- all versions are AEC-Q200 qualified
- optional extra shock proof versions available
- reflow soldering temperature: 260 °C max.
- package height 0.9 mm max.



General Data

type	JTX310
frequency	32.768 kHz
frequency tolerance at 25 °C ± 5 °C	± 20 ppm / ± 30 ppm
load capacitance C _L	12.5 pF std. (7 pF, 9 pF ask)
temperature constant (T _C)	T _C = -0.04 · 10 ⁻⁶ / °C ² max. T _C = -0.034 · 10 ⁻⁶ / °C ² typical
frequency temperature characteristic	f (ppm) = T _C · (25 °C - T) ² T = requested temperature
operating temperature range	refer to frequency stability table
shunt capacitance C ₀	1.15 pF typical
series resistance max. (ESR)	70 kΩ (80 kΩ for temperature range T2 and T3)
storage temperature	-55 °C ~ +125 °C
drive level max.	0.5 μW
aging first year	< ± 3 ppm

Frequency Stability vs. Temperature

		-80 ppm	-160 ppm	-250 ppm	-400 ppm
-20 °C ~ +70 °C	STD.	●			
-40 °C ~ +85 °C	T1		●		
-40 °C ~ +105 °C	T2			○	
-40 °C ~ +125 °C	T3				○

● standard ○ available

Marking

company code
date code / production code

Mechanical Endurance Options

AEC (according AEC-Q200):	100 g, half sine pulse, 6.0 ms
HMR (high mechanical reliability):	3000 g, half sine pulse, 0.3 ms

note: all versions are AEC-Q200 qualified

Dimensions

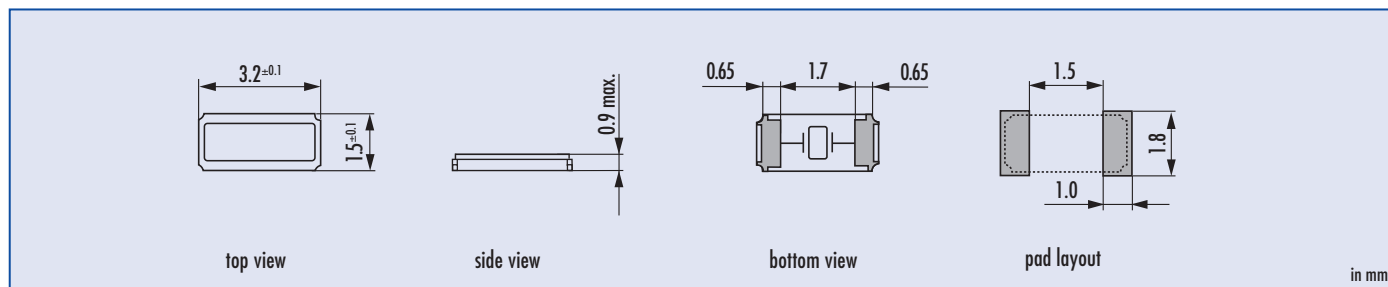

Order Information

Q	frequency	type	load capacitance	stability at 25 °C	option 1	option 2
Quartz	0.032768 MHz	JTX310	12.5 pF 7 pF, 9 pF (ask)	20 ± 20 ppm 30 ± 30 ppm	blank = -20 °C ~ +70 °C T1 = -40 °C ~ +85 °C T2 = -40 °C ~ +105 °C T3 = -40 °C ~ +125 °C	AEC = AEC-Q200 qualified HMR = high mechanical reliability

Example: Q 0.032768-JTX310-12.5-20-T1-AEC-LF (Suffix LF = RoHS compliant / Pb free pads)



Quartz Crystal · JTX310

Taping Specification

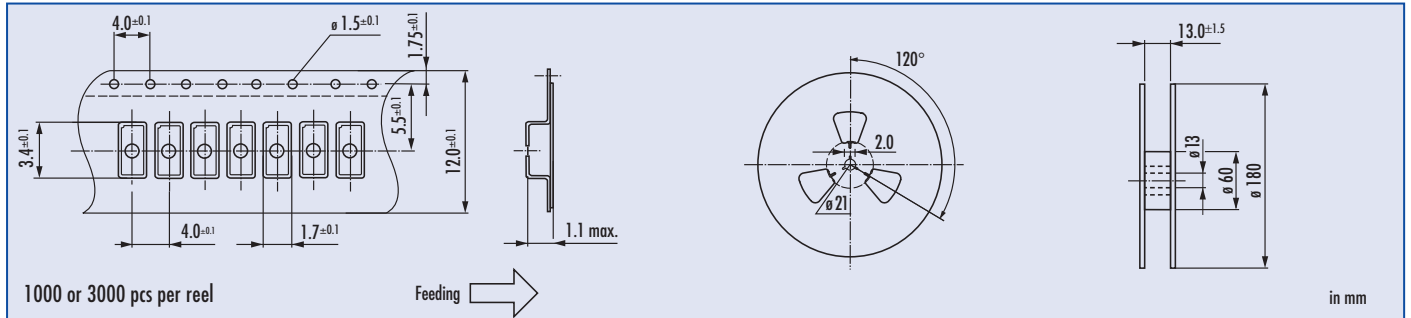

Reflow Soldering Profile

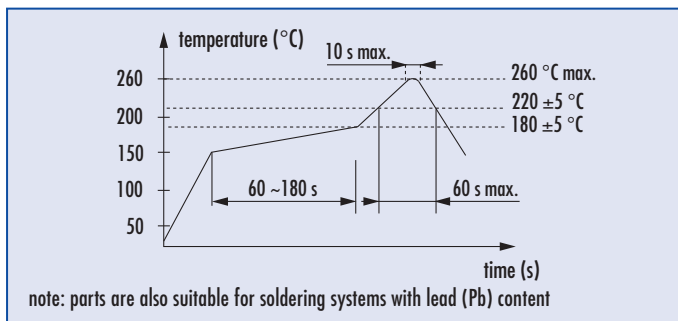





JAUCH QUARTZ...

...A COMPANY ON THE PULSE OF PROGRESS

1954 1960



Quartz – a material with fascinating properties. The most important one is piezoelectricity. What began at Jauch decades ago with the first quartz crystals for electronic clockworks has until today remained the core competence and most important product of our globally active, independent technology firm.

Availability – in today's production world it's a key concept that cannot be overstated. Products not only have to be manufactured but also available 'just in time' – in every corner of the world. And at Jauch Quartz we do a lot to make sure that happens.

In Europe, with Jauch Quartz Germany and Jauch Quartz France, we have our own distribution centers for important markets. And in the US, Jauch Quartz America maintains our continuous presence in the North and South American markets.

A comprehensive network of distribution bases all over the world is ready to supply customers worldwide with Jauch-quality quartz crystals. Because we don't regard our products as mere components that are bought and forgotten: what's important to us is a sustainable relationship with the customer, from careful consulting before a decision to order processing, logistics and long-term field observation. We've noticed again and again that Jauch Quartz customers are customers who stay with us. Because they know what they're getting – wherever they happen to be.



FINDING SOLUTIONS...

...AND IMPLEMENTING THEM

At Jauch Quartz, customer satisfaction is not just an empty phrase, but a living reality. Delivery reliability is a proven fact at Jauch Quartz. Constant deliveries to renowned customers the world over prove that relying on Jauch Quartz means relying on production security. Because for us, overall product quality has always entailed a great deal more than just the product alone. With our Customer Support Center we offer active cooperation in any situation. Even in the concept phase of a development, it's worth discussing an optimal solution with us.

Or do you need a few hundred or a few thousand quartz crystals for your pilot run? We're the quartz specialists, so for us that's part of customer care. It's something that our customers have grown to appreciate.

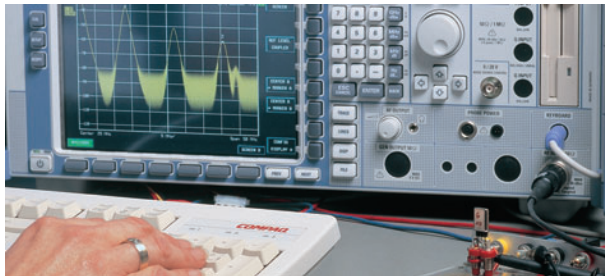

*Safety from high-quality measuring technology:
Special measuring systems, e.g. for analyzing the
frequency spectrum and noise conditions, guarantee that
our customers can rely one hundred percent on the
parameters set.*



*Application service via know-how:
Our development and service department supports our
customers in all questions of circuit design and – on
request – takes a closer look at application
scenarios.*



*Technical service from specialists:
At Jauch, developers find competent contacts
who support them in switch design just as
much as with special measuring technology
requirements.*



B.C.E. s.r.l.
Via Regina Pacis, 54/c - 41049 SASSUOLO (MO) Italy
Tel. +39 0536 811.616 r.a. - Fax +39 0536 811.500
www.bce.it - E-mail: bce@bce.it





- Our own quartz product **development center**
- **Consulting and care** by specialists for quartz products
- **Check-up service:** switching tests with special test devices
- **Fast service** with programmable oscillators for pilot runs and with quartz products in standard frequencies

THE SPECIALIST FOR FREQUENCY CONTROL PRODUCTS

- **Worldwide presence**
- **High availability** for standard frequencies, with over 20 million components off the shelf

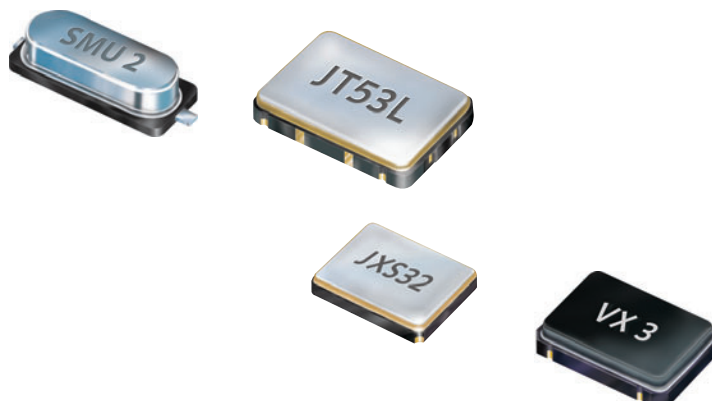

PRODUCTION WORLDWIDE...

...FOR WORLD-FAMOUS BRANDS

Jauch – the world brand for quartz technology. With our own production facilities, we're present in important electronics centers all over the globe. And everywhere we are bound to the same basic principles: high efficiency, reliable delivery, value for money, and highest quality. Because we know how exacting our customers are. And we also know why.

International production,
guaranteed by
universal quality standards

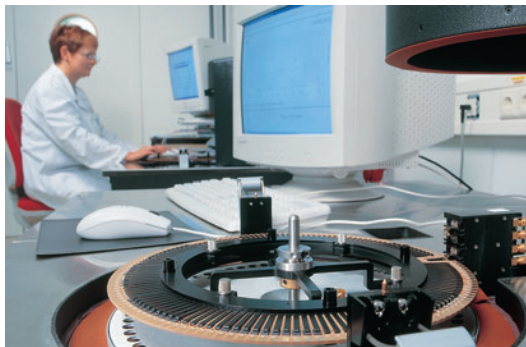

From raw quartz crystal production to special short runs to mass production in the millions in ever-constant quality, Jauch Quartz has a lot of performance to offer – and that applies just as much to large groups of companies as to smaller specialists. High flexibility in product design and production amounts enables us to cover a broad customer and business spectrum and thus maintain our independence.



Technology that makes quality possible: Ultrasound purification of quartz blanks for perfect surfaces.

Grinding of quartz blanks: The right surface for the right clock rate.

Jauch has production facilities at many locations around the world – from Europe to Asia. However different the people at these sites are, they all have one thing in common: they all work according to the same system of values. They all belong to the same corporate culture. That is the only way to produce on different continents and retain a uniform standard. Because wherever Jauch products are on the pulse of progress, the rhythm has to be just right.



B.C.E.
ELECTRONICS
Importation & Distribution
Electronic Components

B.C.E. s.r.l.
Via Regina Pacis, 54/c - 41049 SASSUOLO (MO) Italy
Tel. +39 0536 811.616 r.a. - Fax +39 0536 811.500
www.bce.it - E-mail: bce@bce.it





*The entire quartz crystal
processing chain:
from raw quartz production...*

*...component production using
semi- or fully-automatic production
technology depending on the run size...*

*...to series-oriented quality
assurance and automated
100-percent testing.*



B.C.E. s.r.l.
Via Regina Pacis, 54/c - 41049 SASSUOLO (MO) Italy
Tel. +39 0536 811.616 r.a. - Fax +39 0536 811.500
www.bce.it - E-mail: bce@bce.it



Certificate DIN EN ISO 9001:2000

SGS

Certificate DE05/53347

The management system of

JAUCH QUARTZ GmbH
In der Lache 24
DE-78056 VS-Schwenningen

has been assessed and certified as meeting the requirements of

ISO 9001:2000

For the following activities

**Design, production and sales of crystals,
oscillators, resonators and filters
Sales of batteries**

Further clarifications regarding the scope of this certificate and the applicability of ISO 9001:2000 requirements may be obtained by consulting the organization

This certificate is valid from 6th April 2005 until 5th April 2008
Issue 3. Certified since November 1998

Authorised by

Board of Directors

Certification body



SGS-ICS Gesellschaft für Zertifizierungen m.b.H. und Umweltgutachter
Raboisen 28 20095 Hamburg Germany
t +49 (0)40 30-101-361 f +49 (0)40 33-04-08 www.sgs.com

Page 1 of 1



graphic design: stähler regner photo: printed by: wahl (broad) security printing ltd. wiesbaden



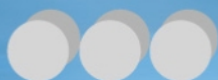

B.C.E. S.r.l. - Via Regina Pacis, 54/c - I 41049 Sassuolo (MO), Italy

Tel: (+39) 0536 811616 Fax: (+39) 0536 811500 E-mail: bce@bce.it Web: www.bce.it

