



# High Performance IC Sockets & Adapters

## SOCKETS



## ADAPTERS

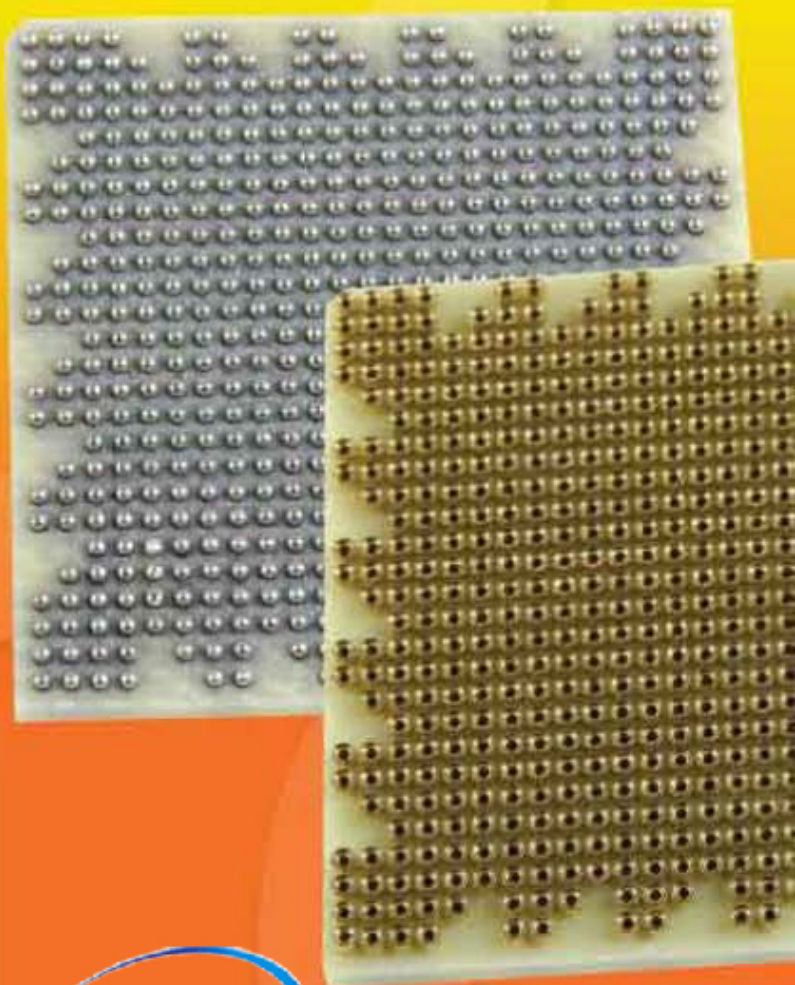

Short Form Catalog 25



# Ironwood ELECTRONICS





<b>Introduction</b> . . . . .	2	<b>Package Conversion</b>	
<b>Custom Engineered Products</b> . . . . .	3	For Production Applications . . . . .	23-24
<b>Sockets</b>		<b>Probing</b>	
GHz Socket Lid Options . . . . .	4	Probing & Analysis Adapters . . . . .	24
Socket Mounting Options . . . . .	5	Logic Analyzer Adapters . . . . .	25
Options to Surface Mount Socket . . . . .	6	Prototyping Adapters . . . . .	25
Contact Technology Summary . . . . .	7	Turn-Key Capabilities . . . . .	26
Pin Technology Summary . . . . .	8		
SilverBallMatrixElastomerSocket . . . . .	9	<b>What's NEW In This Catalog</b> . . . . .	27
Stamped Spring Pin Sockets . . . . .	9	<b>Socket &amp; Adapter Examples</b> . . . . .	28
GHz BGA . . . . .	10-11	<b>Cross References</b> . . . . .	29
Epoxy Sockets . . . . .	11	<b>New Product</b> . . . . .	30
GHz QFN . . . . .	12		
CG-BGA, CG-QFN, SG-SOIC . . . . .	12		
SG-QFE . . . . .	13		
Giga Spring Pin Sockets . . . . .	13		
40 GHz-Burn-In . . . . .	13-14		
Through Hole Adapters . . . . .	15		
SMT Adapters . . . . .	15		
<b>SMT Package Emulation</b>			
SMT Feet . . . . .	16		
Giga-snaP™ BGA . . . . .	18		
LS-QFN/MLF . . . . .	19		
SF-MLF (QFN) . . . . .	19		
QFP . . . . .	20		
SOIC . . . . .	20		
PLCC . . . . .	20-22		
Receptacles . . . . .	21		

## Mission Statement

Ironwood Electronics is committed to developing new technologies and methods in IC interconnection for the purpose of providing superior products and service for our customer's overall requirements. We offer the most comprehensive test and prototype adapter and socket line in the industry. We have detailed knowledge of interconnect technology in the areas of electrical, mechanical and software engineering. Products are designed for superior mechanical and electrical integrity utilizing the most advanced technologies. Continuous and open communication with our suppliers ensures top quality materials and on-time delivery. We are dedicated to quality in the services we provide and the parts we manufacture.

Catalog 25

©2014 Ironwood Electronics, Inc.

# Introduction

Ironwood Electronics creates innovative IC interconnect solutions in prototype, test, and production applications for use in both product development and ongoing production.

## What is in the catalog

The Short Form Catalog V. 25 is an abbreviated version of the information found on our web site. It contains an overview of each product line. Detailed information on a given part can be found on the web site. In addition, the web site contains drawings, maps, photos, specifications, and other information on the products so that you can quickly determine suitability for your application.

## How to Use the Web site With This Catalog [www.ironwoodelectronics.com](http://www.ironwoodelectronics.com)

Each section of the catalog has specific pointers to find drawings for a part in the different product lines. For instance for the GHz BGA product line, the pointer for these drawings is found at [http://www.ironwoodelectronics.com/products/sockets/sockets\\_list.cfm](http://www.ironwoodelectronics.com/products/sockets/sockets_list.cfm) and then select GHz BGA Sockets. When a product line is selected, a Standard Parts list will appear with parts tables and technical documents. After selecting a Standard Parts table, scroll through the table to select your product and click on a part number. When a product is selected, a window appears with the documentation and other information listed. Simply view the documentation on the selected part.

In addition to the Browse function you can search for a product with two different methodologies. The first is by part number where you enter the part number or a portion of a part number. A listing of the part(s) is returned after search activation. The second option is searching by package type, pitch, and pin counts. All parts for a given combination of these will be returned by the search. The web site also contains extensive information on product presentations, distributors, and new products. Ordering can also be quickly accomplished online.

## Can't find your solution? Call us!

We will design a custom solution for your unique problem. The electronics industry is constantly changing with new packages, higher speed systems, and increasing miniaturization. We have an engineering staff with electrical and mechanical engineering capability to solve the most challenging packaging and electronic design problem. We can quickly convert the design to a practical solution sometimes within a few days. See page 3 for more details on engineered solutions.

## Lead-Free Solutions Available

Ironwood Electronics has developed many RoHS compliant sockets and adapters. This applies to custom products as well as standard products.



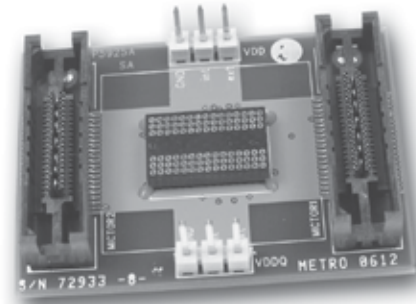

Ironwood has created thousands of custom adapters. A few recent ones are illustrated. Ironwood Electronics has the largest, most experienced staff of electrical and mechanical engineers in our industry. Quick turn custom projects are a cornerstone of our business. Our engineers utilize advanced CAD tools to help us design quality into each of our products. We are committed to developing high density interconnect technologies. Many of our innovative designs incorporate technologies such as:

- Controlled Impedance
- <0.8mm pin grid arrays
- Conductive Elastomers
- Blind/Buried Vias
- 3 mil Line & Space
- Embedded Resistors
- Laser Micro Vias
- Shaped Solder
- Flexible PCBs
- RoHS to Lead Adapters

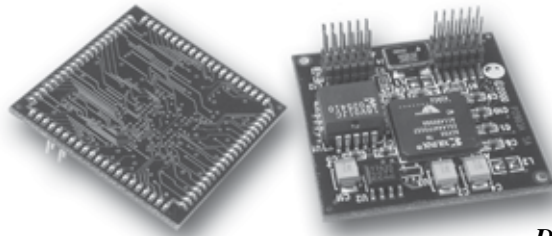

*Daughter Card module for obsolete IC*

## ISO 9001 Certified Design Process

### Ordering custom adapters

We will be pleased to quote custom adapters to meet your requirements. When asking for a quote, you will need to provide the following information:

- Delivery schedule requirements
- Number of parts needed
- Description of your application (and drawings if possible).

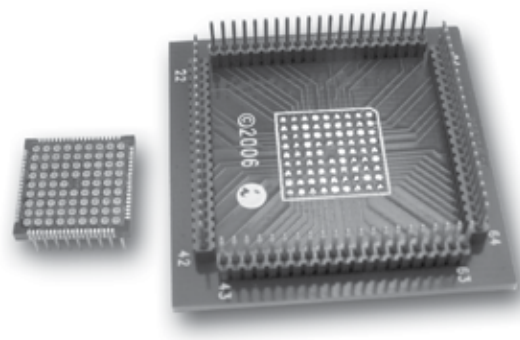

*QFP Probing Adapter*

In many cases custom solutions are feasible using off-the-shelf parts, allowing for fast delivery time and reduced NRE costs. In general, custom interconnect adapters can be developed and manufactured in 4 to 6 weeks. With increased NRE charges some adapters can be developed and manufactured in 1 to 2 weeks.

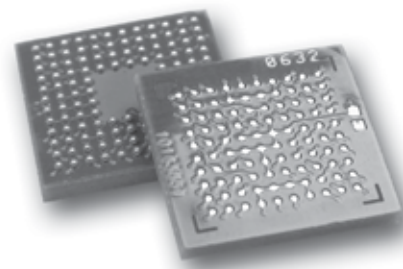

*BGA Fix Adapter*

**IMPROVED SWIVEL LID**

- Easier-to-use swivel lid
- Maintains low-profile design
- Quick IC installation

**FORCE INDICATING COMPRESSION SCREW**

- No tools required
- Reliable installation
- Available for all IC's

**DOUBLE LATCH LID**

- Fully removable lid
- Optional heat sink
- Easy access to IC

**HEAT SINK COMPRESSION SCREW**

- Easy 2-in-1 installation
- Up to 100 watts
- Optional fan available

**CLAM-SHELL LID**

- Easy to use snap lid
- Quick IC installation
- Low-profile designs available

**OPEN TOP LID**

- Easy access to chip
- Optical applications
- Thermal applications

# Socket Mounting Options

## Ironwood Socket Mounting Options

### Direct mount with Hardware

For target boards with BGA pads and Ironwood socket mounting holes

- Will work for all IC sizes
- requires backing plate and insulation plate on back of target board
- shortest signal path from BGA IC to target board
- requires target PCB be designed to socket footprint
- socket footprint is only 5mm larger than IC package

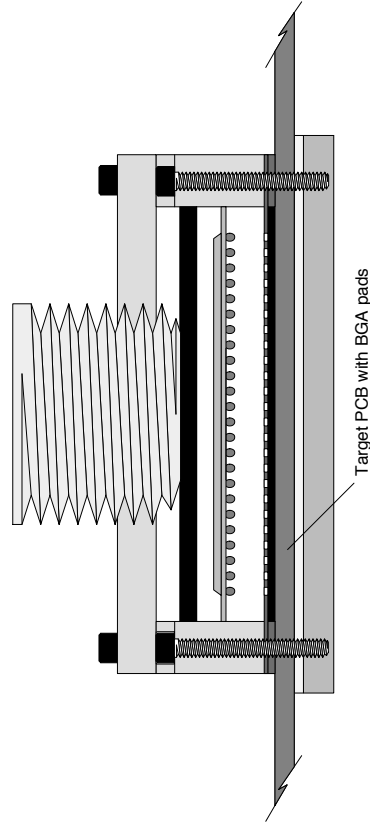

### Epoxy Mount

For target boards with BGA pads

- Will work only for small IC sizes and/or small pin count
- shortest signal path from BGA IC to target board
- requires real estate around BGA outline of 10mm (5mm per side)
- additional space needed for epoxy
- socket may be difficult to remove after attaching

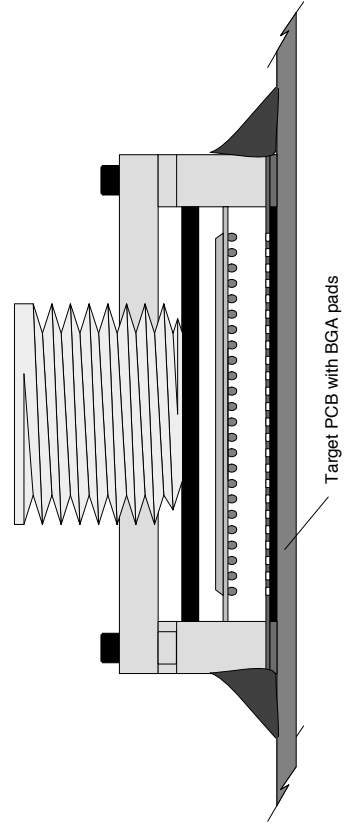

### Surface Mount

For target boards with BGA pads

- Will work only for all BGA package sizes
- longer signal path from BGA IC to target board due to SMT adapter
- requires real estate around BGA outline of 10mm (5mm per side)
- requires SMT reflow to target PCB

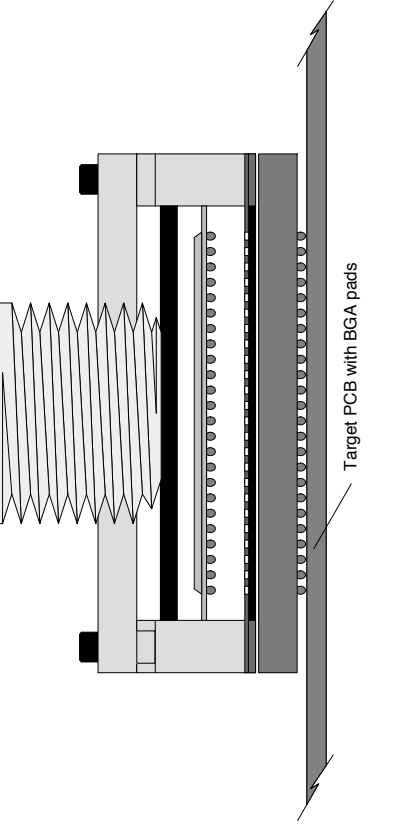

### Thru-Hole Mount

For target boards with BGA Thru-hole pattern

- Will work only for all BGA package sizes
- longer signal path from BGA IC to target board due to SMT adapter
- requires real estate around BGA outline of 10mm (5mm per side)
- requires thru-hole reflow to target PCB

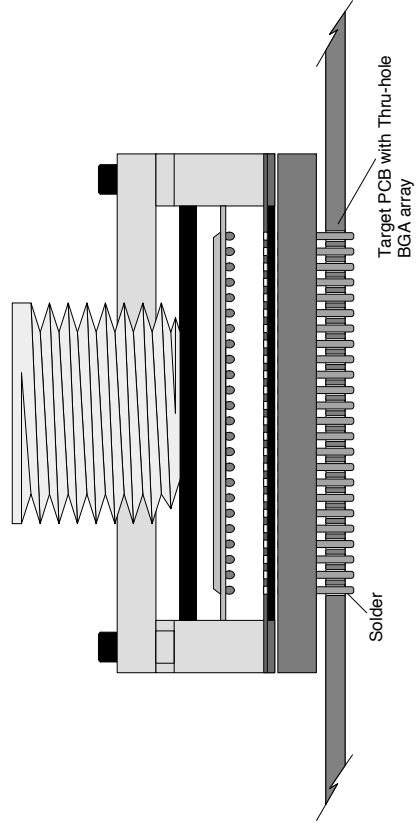

# Options to Surface Mount an Ironwood GHz Socket

## Options to surface mount an Ironwood GHz socket

(no mounting hardware required)

### Option # 1

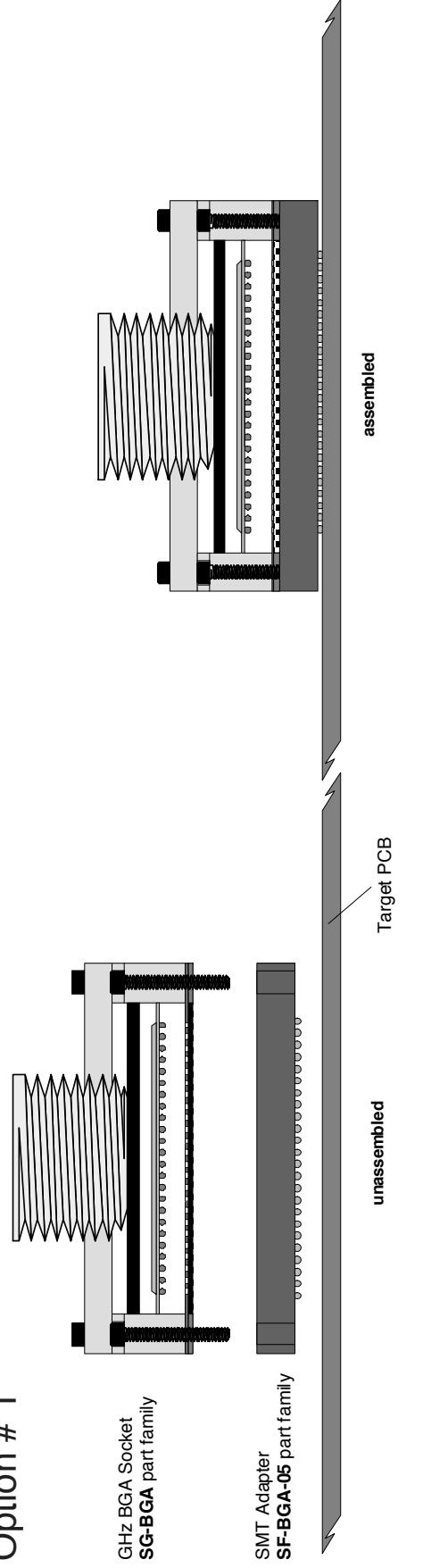

### Option # 2

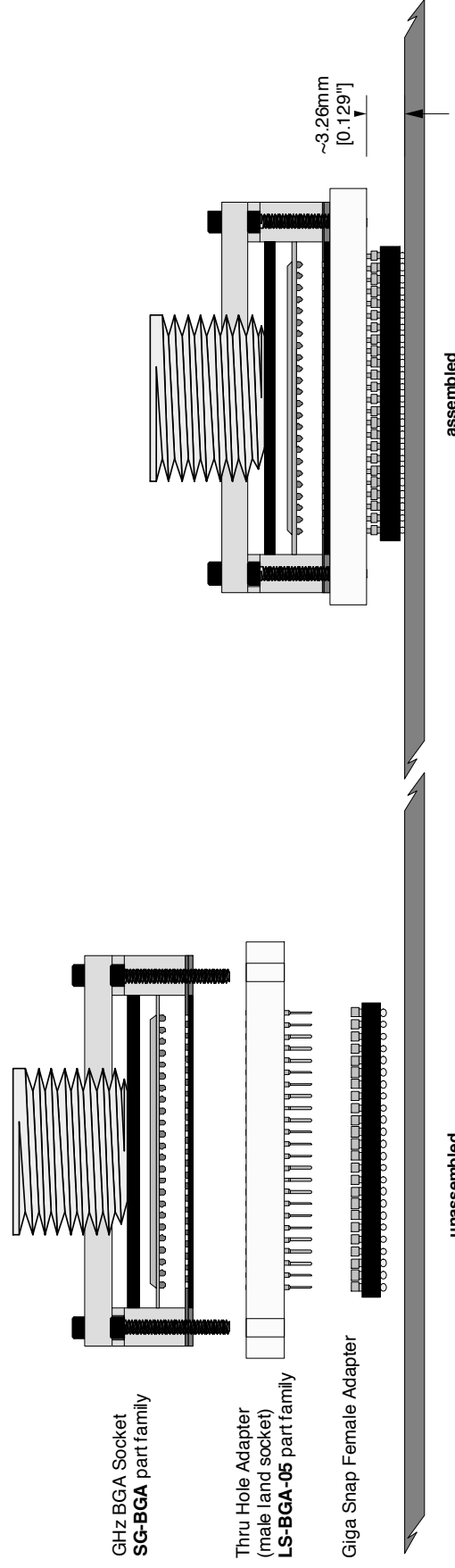

Note: Drawing not to Scale

# Contact Technology Summary



Characteristics	Embedded Wire Elastomer (SG)	Spring Pins (SS)	Embedded Silver Particle Elastomer (XG)	Stamped spring pins (SBT/HBT)	Embedded Silver Ball Elastomer Matrix (SM/SMP)
Bandwidth, GHz	8 to 10	6 to 12	40	7 to 31.5	40
Endurance, Cycles	2K	500K	10K	500K	10K/500K
Resistance, mΩ	20	50	50	15	15
Self Inductance, nH	0.15	1.1	0.11	0.88 to 0.95	0.21
Max Current, Amp	2	5	5	8	4
Temp Range, °C	-35 to +100	-40 to +150	-40 to +120	-55 to +180	-55 to +155
Pitch, mm	0.3 to 1.27	0.3 to 1.27	0.4 to 1.27	0.4 to 1.27	0.25 to 1.27
Package Types	BGA, QFN, QFP, SOIC	BGA, LGA, QFN, QFP, SOIC	BGA, QFN, LGA	BGA, LGA, QFN, QFP, SOIC	BGA, LGA, QFN
Lab test	✓	✓	✓	✓	✓
Production test		✓		✓	✓
Field upgrade	✓			✓	
Temperature test	✓	✓	✓	✓	✓
Kelvin test	✓	✓	✓	✓	✓
Burn-in test		✓		✓	

# Pin Technology Summary

Pin Family	SBT P-P168A	SS P-P134A	SBT P-P163A	SS P-P136A	SBT P-P149A	SS P-P115A	SBT P-P150A	SS P-P114A	SBT P-P151A	SS P-P112A	SBT P-P152A
Minimum Pitch (mm)	0.4	0.4	0.4	0.4	0.5	0.5	0.5	0.8	1.0	1.0	1.0
Pin Type	BGA	BGA	LGA	LGA	BGA	BGA/LGA	LGA	BGA	BGA	BGA/LGA	LGA
Length (mm)	3.3	5.18	3.3	5.18	3.4	4.11	2.95	4.78	5.69	2.79	4.45
DUT Side Tip Shape	V Shape	Crown	Radius Cone	Crown	U Shape	Crown	Radius Cone	Crown	Notched V	Crown	Radius Cone
DUT Side Tip Dimension (mm)	0.13	0.13	0.04	0.13	0.18	0.1	0.06	0.25	0.54	0.52	0.1
PCB Side Tip Shape	Radius Cone	Radius Cone	Radius Cone	Crown	Radius Cone	Radius Cone	Radius Cone	Radius Cone	Radius Cone	Radius Cone	Radius Cone
PCB Side Tip Dimension (mm)	0.18	0.05	0.18	0.11	0.06	0.05	0.06	0.05	0.1	0.1	0.1
DUT Side Travel (mm)	0.4	0.28	0.4	0.28	0.33	0.2	0.33	0.57	0.6	0.2	0.6
PCB Side Travel (mm)	0.2	0.1	0.2	0.1	0.1	0.1	0.1	0.1	0.1	0.1	0.1
Force (g)	34	20	34	20	30	16	30	22	19	30	19
Cres (mOhms)	< 70	< 70	< 70	< 70	< 30	< 100	< 30	< 25	< 15	< 35	< 15
CCC @ ambient (Amps)	2.2	1.7	2.2	1.7	6.0	2.5	6.0	3.0	8.0	4.0	8.0
Bandwidth (GHz @ -1dB)	7 - 9.1	11.5	7 - 9.1	11.5	5.2 - 15.7	6	5.2 - 15.7	6.7	14.1 - 21.9	10	14.1 - 21.9
Self Inductance (nH)	0.95	1.1	0.95	1.1	0.88	1.3	0.88	0.84	0.93	0.62	0.93
Temperature (deg C)	-55 to +155C	-40 to +120C	-55 to +155C	-40 to +120C	-55 to +180C	-40 to +150C	-55 to +180C	-40 to +120C	-55 to +180C	-40 to +150C	-55 to +180C
Insertion Cycles	500K	500K	500K	500K	500K	500K	500K	500K	500K	500K	500K

\* 0.5mm pitch SBT pins are used in 0.65mm and 0.8mm pitch applications

# Silver Ball Matrix Elastomer Socket



Ironwood Electronics SM/SMP socket uses SM & SMP contact technology for high speed, low inductance, high endurance and wide temperature applications. SM Contact is a unique contact that has precise silver balls held together by a proprietary conductive formulation. These conductive columns (diameter optimized for 50 ohm impedance) are suspended in a non-conductive flexible elastomer substrate with a patented solid core for enhanced durability and reliable performance over time, temperature and cycles. This flexible substrate is very compliant and resilient and enables the conductive columns to revert back to original shape when the force is removed. Solutions are available for 0.25mm to 1.27mm LGA, BGA, QFN, CSP, POP, WLP and other packages. The silver ball matrix contact technology is also available with a protective plunger matrix (a gold plated copper cylinder) that sits on top of the conductive columns. This plunger matrix protects the conductive column from contamination from various solder ball interfaces. A quickly replaceable plunger matrix enables minimal downtime during final production test. The product family code for this line of sockets is **SMP**.

Typical specifications for the contact technology include:

- Over 40GHz bandwidth @-1dB for edge pins
- Contact resistance under 15mOhms
- Self inductance under 0.21nH
- Capacitance under 0.15pF
- Operating temperature range -55C to +150C
- Insertion/Extraction life over 500, 000 cycles with protective plunger matrix
- Current rating at 14C temperature rise is 4 Amps per pin

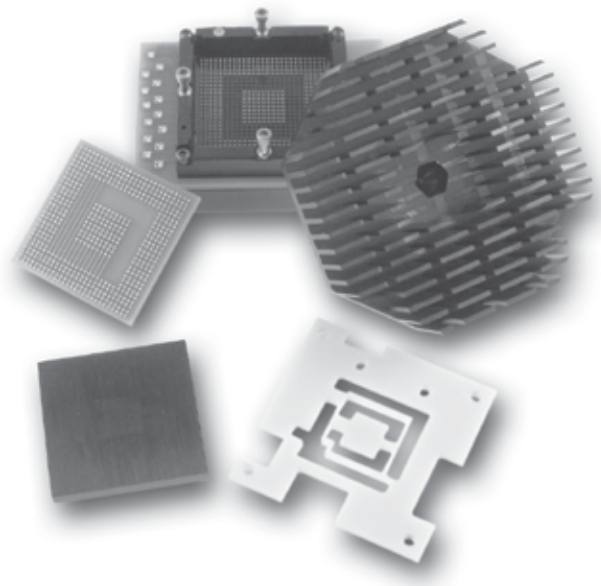

For drawings -> [www.ironwoodelectronics.com/products/sockets/silver\\_ball\\_matrix\\_sockets.cfm](http://www.ironwoodelectronics.com/products/sockets/silver_ball_matrix_sockets.cfm)

# Socket For Burn-In and Test Applications

Ironwood Electronics SBT sockets are small footprint sockets that are compatible with other product lines such as GHz elastomer sockets, Giga-Spring sockets, etc. SBT socket uses SBT contact technology for high endurance and wide temperature applications. The SBT Contact is a stamped contact with outside spring as well as inside leaf spring that provides a robust solution for Burn-in & Test applications. Solutions are available for 0.4mm to 1.27mm LGA, BGA, QFN, QFP, SOIC and other packages. Contact technology has 3 part system which includes top plunger, bottom plunger and a spring. The Beryllium Copper plungers are stamped and assembled to a stainless steel spring in an automated system to enable fast turnaround time, low cost and zero defects.

Typical specifications for the contact technology include:

- Over 20GHz bandwidth @-1dB
- Contact resistance under 15mΩ
- Self inductance under 1nH
- Capacitance under 0.3pF
- Operating temperature range -55C to +180C
- Insertion/Extraction life over 500, 000 cycles
- Current rating at 80C temperature rise is 4 to 8 Amps per pin

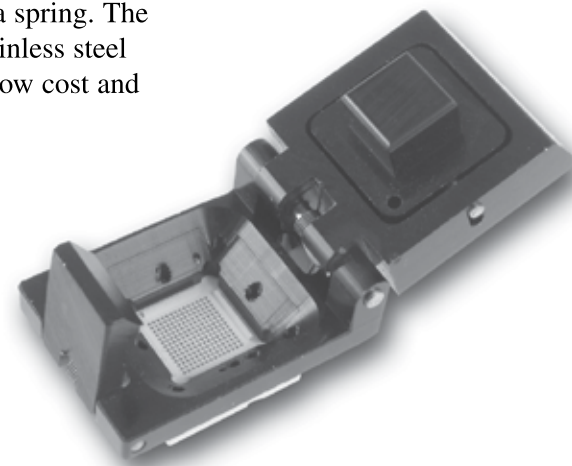

For drawings -> [www.ironwoodelectronics.com/products/sockets/sbt.cfm](http://www.ironwoodelectronics.com/products/sockets/sbt.cfm)

# GHz BGA SMALL Socket For Ultra High Speed- 0.75mm to 1.27mm Pitch

*Optional heatsinks available for up to 100 Watts*

Ironwood's GHz BGA sockets (SG-BGA-6xxx) are ideal for prototyping and testing almost any BGA device application. These ZIF sockets provide excellent signal integrity yet remain cost effective. We use an innovative interconnect technology that delivers low signal loss (1dB at 8 GHz) and can support BGA pitches down to 0.3mm. The optional contactor has bandwidth over 10 GHz. Our sockets require far less PCB space than traditional mechanical-type sockets – only 2.5 mm larger perimeter than the IC.

Ironwood's unique patented designs utilize a high-performance elastomer to provide electrical connections to the BGA chip. The elastomer can be continuously used in applications with temperatures up to 100°C, with intermittent peaks to 150°C. Each socket is a precision device, guiding the IC to the exact position for connection and does not damage solder balls.

The most common GHz BGA sockets are mechanically mounted over a target system's BGA lands. They support IC devices with body sizes ranging from 60mm down to 1mm. Larger body sizes may require a backing plate.

**Note: The typical socket will accommodate depopulated BGAs. For instance, a 14x14 array with 132 pins will fit in a socket with a max Ball Count of 196.**

For drawings -> [www.ironwoodelectronics.com/products/sockets/ghz\\_bga\\_qfn\\_sockets.cfm](http://www.ironwoodelectronics.com/products/sockets/ghz_bga_qfn_sockets.cfm)

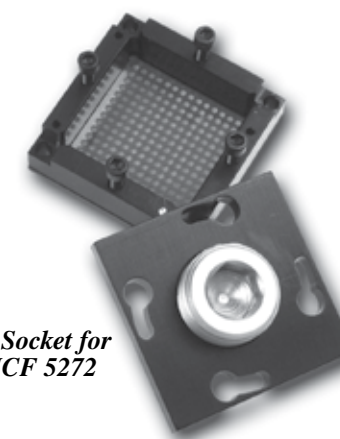

*15mm GHz Socket for Motorola MCF 5272*

High-speed sockets and adapters continue to perform important functions for IC component testing, prototyping, and production, requiring an ever-increasing level of electrical and mechanical performance. In the area of electrical performance, it is particularly important that an accurate predictive model be available for performance at GHz frequencies. High speed simulation data helps test engineers with initial selection of a proper interconnect design, and also serves as a predictor of performance over a variety of simulated end-use conditions.

S-Parameter Simulation data for GHz BGA sockets available on website at [www.ironwoodelectronics.com/catalog/Content/Drawings/IE\\_SI\\_paper.pdf](http://www.ironwoodelectronics.com/catalog/Content/Drawings/IE_SI_paper.pdf)

SG-BGA-8xxx sockets are high performance BGA sockets for 0.8mm, 1mm, and 1.27mm pitch BGA packages. The sockets operate at bandwidths up to 10 GHz with less than 1dB of insertion loss. They are designed to dissipate up to several watts without extra heat sinking and can be customized to handle up to 100 watts. The contact resistance is typically 23 milliohms per pin. The SG-BGA-8xxx is constructed with high performance and low inductance elastomer. The temperature range is -35 C to +100 C. The pin inductance is 10.15 nH and Capacitance to ground is 0.10 pF.

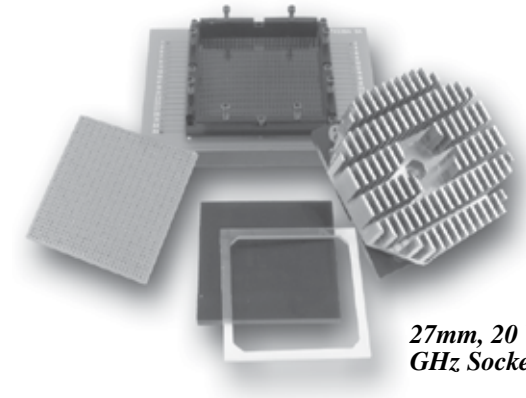

*27mm, 20 Watt BGA GHz Socket*

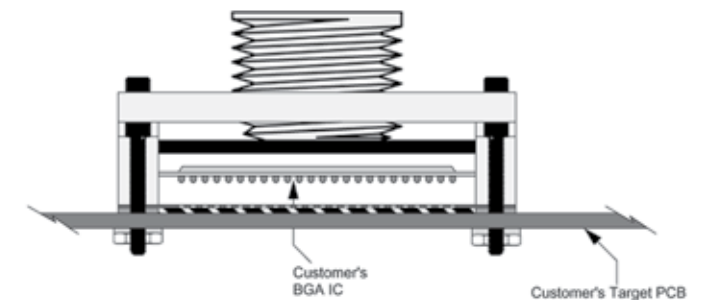



The High Density GHz BGA sockets allow prototyping and testing of 0.5 and 0.75 mm pitch BGA's with bandwidths of over 10 GHz. These small ZIF sockets provide excellent signal integrity allowing operation of circuits in any application including RF, GHz networking and high speed computing. The new 10 GHz bandwidth sockets easily support very dense BGA devices utilizing a high performance conductive elastomer contactor. The socket is a precision device, which guides the IC to the exact position for connection of each ball and uses an aluminum heat sink screw to provide compressive force. The SG-BGA-7XXX accommodates IC packages such as the Xilinx CP132, 0.5 mm pitch, 14X14 array.

These patented ZIF sockets are simply mechanically mounted to the target PCB. The socket lid is twisted open, the IC is inserted, the lid is closed and an aluminum heat sink screw is rotated to provide downward force on the IC. The sockets are 5 mm high and only 2.5 mm per side larger than the actual IC packages, minimizing footprint on system boards while maximizing system speeds. The socket body and heat sink screw are constructed with aluminum to facilitate heat-sinking.

For drawings -> [www.ironwoodelectronics.com/products/sockets/ghz\\_bga\\_qfn\\_sockets.cfm](http://www.ironwoodelectronics.com/products/sockets/ghz_bga_qfn_sockets.cfm)

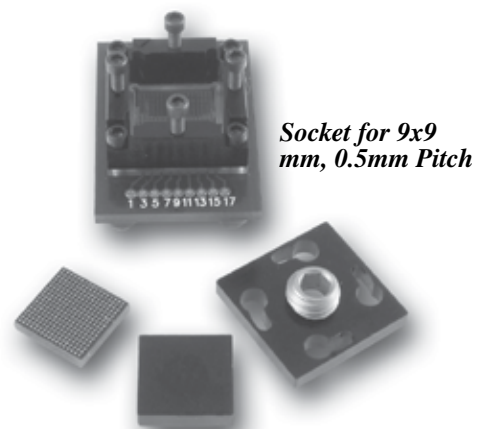

## Epoxy Sockets

If through-holes are unacceptable, or if an even smaller footprint is required, an epoxy mounting option may be considered. While this creates a more or less permanent bonding of the socket to the PC Board, the socket is designed such that the contacting elements are replaceable should damage or excessive wear occur. These patented ZIF sockets are simply mounted to the target PCB by an epoxy band around the perimeter. The socket is placed into position with a precision alignment tool and epoxied in place. A bead of epoxy around the socket strongly holds it in place. There are special grooves on the socket wall for additional epoxy strength. The contactor can be easily replaced after hundreds of cycles.

For drawings -> [www.ironwoodelectronics.com/products/sockets/ghz\\_bga\\_qfn\\_sockets.cfm](http://www.ironwoodelectronics.com/products/sockets/ghz_bga_qfn_sockets.cfm)

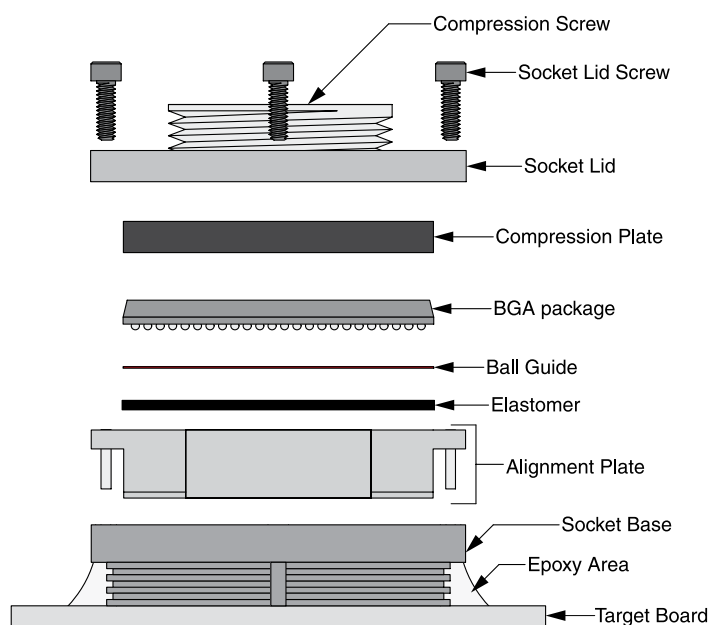
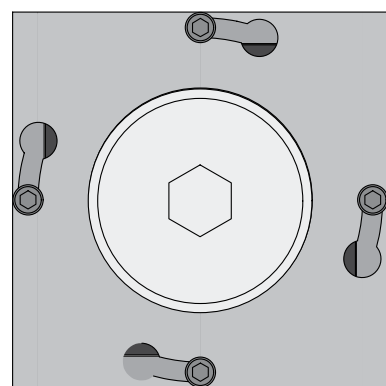
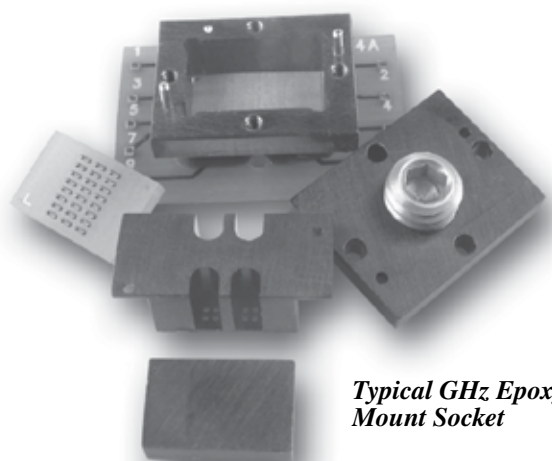

For detail socket mounting instructions, visit our web site at [www.ironwoodelectronics.com/catalog/Content/Drawings/EPM.pdf](http://www.ironwoodelectronics.com/catalog/Content/Drawings/EPM.pdf)

GHz QFN High density Sockets allow 0.4 mm pitch QFN (also called MLF, MLP, LPCC, QLP, HVQFN and LFCSP, just to name a few) IC's to be socketed and operate without compromising performance in very high speed communication or computing applications. The new 10 GHz bandwidth sockets easily support very dense QFN devices utilizing a high performance conductive elastomer contactor. The socket is a precision device, which guides the IC to the exact position for connection of each lead and uses an aluminum heat sink screw to provide compressive force. The SG-MLF-7000 accommodates IC packages such as the Amkor MLF68, 0.5 mm pitch.

These patented ZIF sockets are mechanically mounted to the target PCB. The socket lid is twisted open, the IC is inserted, the lid is closed and aluminum heat sink screw is rotated to provide downward force on the IC. The sockets are 5 mm high and only 2.5 mm per side larger than the actual IC packages, minimizing footprint on system boards while maximizing system speeds. The socket body and heat sink screw are constructed with aluminum to facilitate heat sinking.

For drawings -> [www.ironwoodelectronics.com/products/sockets/ghz\\_bga\\_qfn\\_sockets.cfm](http://www.ironwoodelectronics.com/products/sockets/ghz_bga_qfn_sockets.cfm)

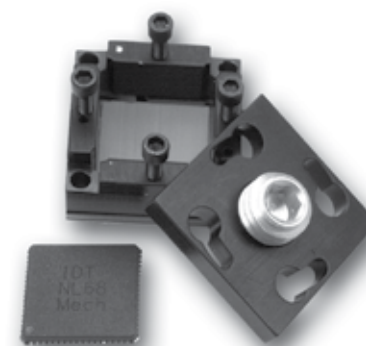

## CG-BGA, CG-QFN

Clamshell BGA elastomer sockets have foot prints compatible with our standard GHz type sockets. These sockets enable for an easy access to the chip and are suitable for applications where chips need to be changed more frequently. CG-BGA sockets allow prototyping and testing of BGA packages with pitch as low as 0.4mm with frequency up to 10 GHz and have an option to use heat sinks up to 100 W.

For drawings -> [www.ironwoodelectronics.com/products/sockets/ghz\\_bga\\_qfn\\_sockets.cfm](http://www.ironwoodelectronics.com/products/sockets/ghz_bga_qfn_sockets.cfm)

Clamshell GHz Socket for 23x23mm BGA



## SG-SOIC

Ironwood has introduced new GHz sockets for SOIC chips. The sockets are ZIF sockets and provide excellent signal integrity. The sockets are compact and can be mounted on the small footprint. The signal path is short (0.5mm or 0.75mm). The operating temperature is from -35 deg. C to 100 deg. C. It uses elastomeric interconnect technology and the signal loss is less than 1 dB at 6.5GHz or 10GHz. The contact resistance is typically 23 milliohms per lead. The SOIC leads are precisely guided in the socket.

There are two options available to mount these sockets. The socket can be mounted using hardware and needs holes for screws and for positioning on the target board. If the holes can not be drilled on the target board, epoxy mount sockets are the other option. Epoxy mount sockets use epoxy to mount the socket on the target board.

For drawings -> [www.ironwoodelectronics.com/products/sockets/ghz\\_bga\\_qfn\\_sockets.cfm](http://www.ironwoodelectronics.com/products/sockets/ghz_bga_qfn_sockets.cfm)



# SG-QFE

Combining a small footprint with high performance, Ironwood Electronics QFE socket 10+GHz bandwidth socket (<-1 dB at 10GHz) supports very dense pitch QFP devices. These are constructed with a high performance and low inductance elastomer with a contact resistance close to 23 milliohms per pin.

For drawings -> [www.ironwoodelectronics.com/products/sockets/ghz\\_bga\\_qfn\\_sockets.cfm](http://www.ironwoodelectronics.com/products/sockets/ghz_bga_qfn_sockets.cfm)

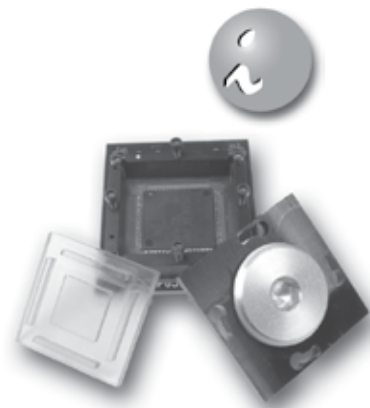

GHz QFE Socket for 14x14mm Body Size

# Giga Spring Pin Sockets

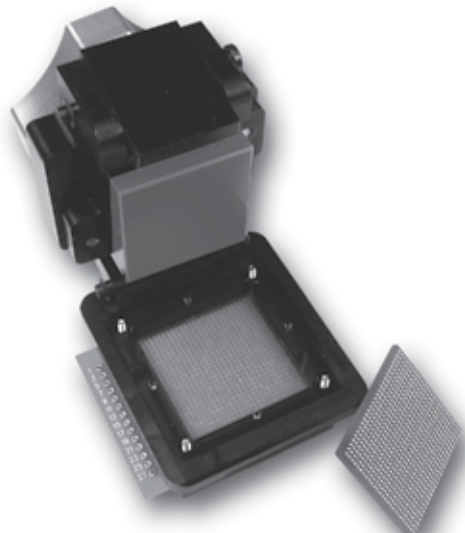

GHz Bandwidth, 500,000 insertions

Ironwood Electronics Giga-Spring™ (POGO) are small footprint socket compatible with the GHz elastomer sockets with increased endurance and temperature range. The 1mm contactor is a spring pin (pogo) with 30 gram actuation force per ball and cycle life of 500,000 insertions. The self inductance of the contactor is 0.62 nH with a loss of < 1 dB at 10 GHz. The current capacity of each contactor is 4 amps at ambient temperature. Socket temperature range is -40C to +150C. The socket is mounted to the PCB with a backing plate and requires only 2.54mm border around the IC. The socket is constructed of aluminum which provides heatsinking up to 7.5 watts. Custom heatsinks can easily be designed for higher power dissipation. The user simply places the IC into the socket, closes the lid, and rotates the heatsink screw to seat the IC. PCB finish on pads can be HASL, Immersion, Au, Immersion Ag, or tin. The Giga-Spring family of sockets provide a small footprint high endurance socket for 0.4 to 1.27mm pitch BGA, LGA, and QFN IC's.

For drawings -> [www.ironwoodelectronics.com/products/sockets/spring\\_pin\\_sockets.cfm](http://www.ironwoodelectronics.com/products/sockets/spring_pin_sockets.cfm)

# 40 GHz Test Sockets for BGA, LGA, and QFN

Ironwood Electronics' new GHz Test sockets are for high temperature, high current, and high frequency applications. The socket uses high temperature conductive elastomer with gold over nickel cap. The sockets deliver the clearest possible signal due to the extremely short current path, low resistance, and ultra-low inductance and capacitance. The socket comes with overcompression stop. The interconnect consists of gold/nickel plated copper pads that makes contact with package leads. The interconnect can be cleaned in minutes. Typical specifications for the interconnect include:

- 40 GHz Bandwidth
- 0.11 nH Self Inductance
- 0.015 nH Mutual Inductance
- 0.028 pF Mutual Capacitance
- Less than 50 mOhms Contact Resistance
- -40 C to 155 C
- 5 Amps per pin
- 15-25 grams per pin

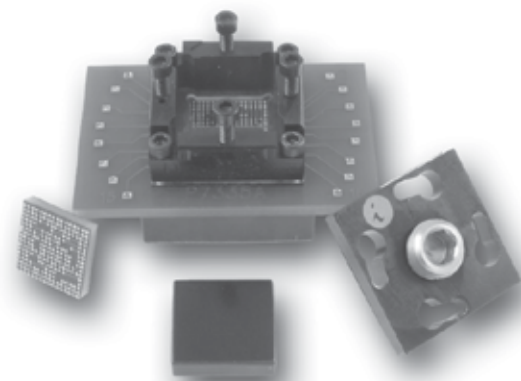

High temp. interconnect socket for 8x8mm BGA

For drawings -> [www.ironwoodelectronics.com/products/sockets/silver\\_particle.cfm](http://www.ironwoodelectronics.com/products/sockets/silver_particle.cfm)

# 40 GHz Burn-in and Test Sockets for BGA, LGA, and QFN

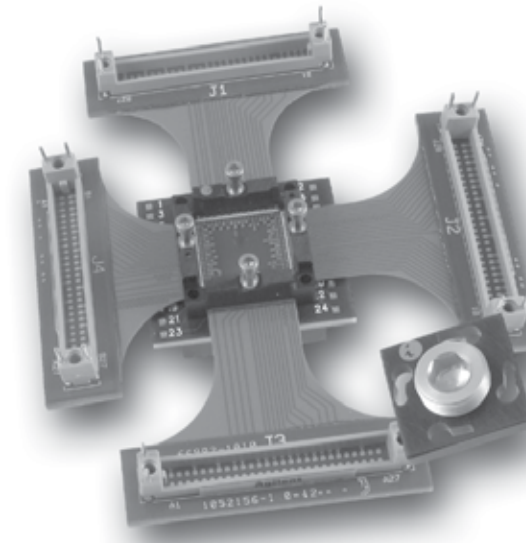

This conductive elastomer can also be used in multi-level stacked interconnection as depicted below:

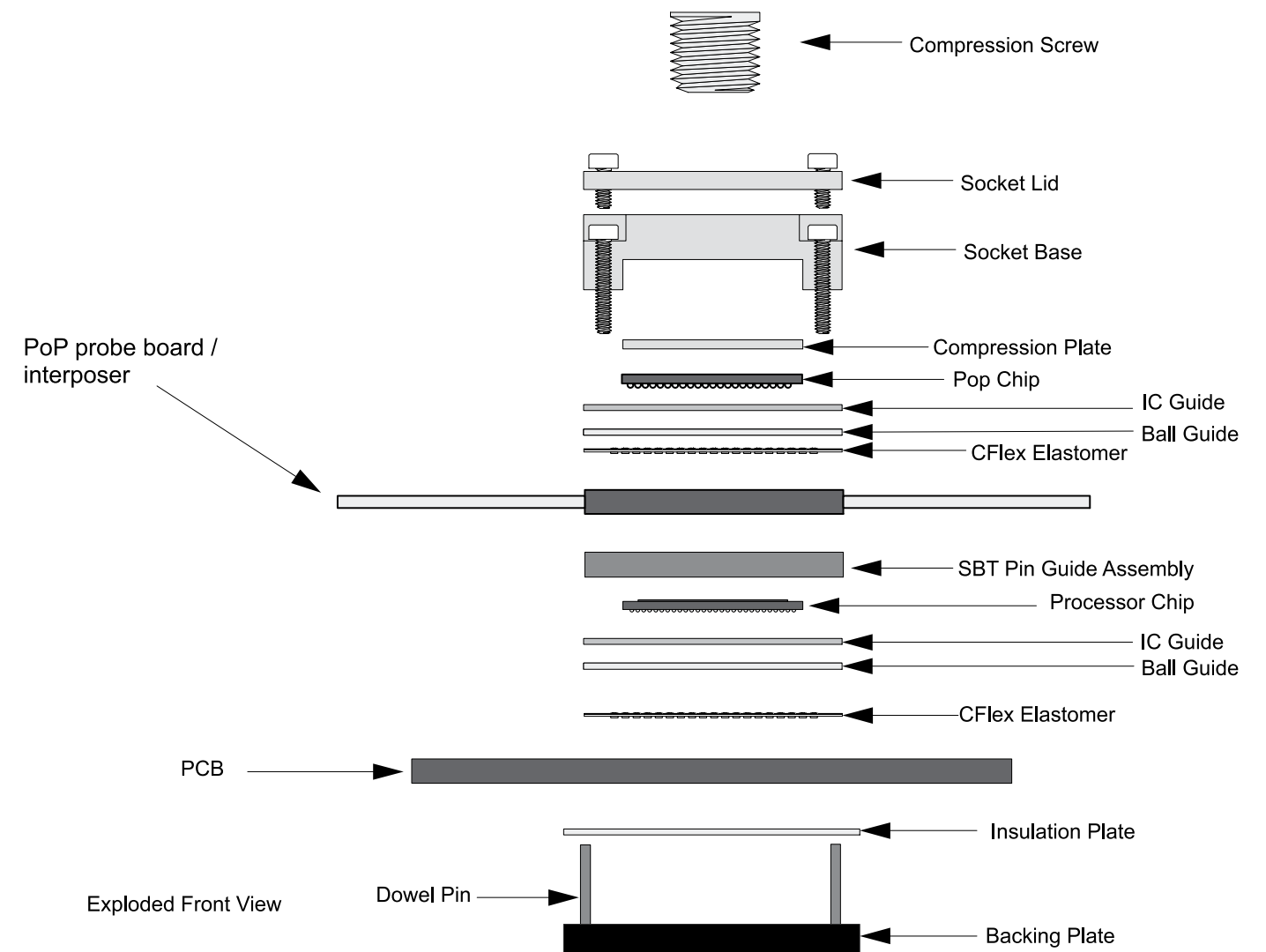





## Surface Mount Package Emulators

The following types of SMT package emulator adapters are available in our on-line catalog. For your convenience, we have listed the compatible mini grid array socket for each part in the tables. Please refer to Appendixes at [www.ironwoodelectronics.com](http://www.ironwoodelectronics.com) -> Appendixes for detailed chip package and package code specifications.

### • BGA - Male Interface

These BGA surface mount feet are easily attached to target boards using standard flux and reflow methods. They present an array of gold plated pins, for pluggable connections to parts like probe boards and in-circuit emulator adapters. Ironwood has developed innovative interconnection technology that supports 0.8mm BGA packaging.

### • BGA - Female Interface

These BGA surface mount feet present a female interface. We utilize blind pin technology to isolate our low temperature solder balls (63/37 PbSn) from the pins.

### • QFP

Our proprietary shaped solder technology, gull wing leads, or leadless systems are employed to attach the part to the SMT lands. These parts typically present our MGA array of gold plated pins to provide pluggable connections.

### • SOIC

Our SOIC surface mount feet are offered in leadless (-L), J-leaded (-J), or bottom termination (-K) variations. When soldered to the target SMT lands, they create a pluggable connection by presenting an array of gold plated pins.

### • PLCC - SMT Bases

Our PLCC surface mount feet utilize J-leads to attach to the target system's SMT lands. They present an array of gold plated, .05" pitch MGA "mini-grid" pins. There are various part profiles and pin length configurations available.

## Surface Mount Package Emulation

### • PLCC - Clip on bases

Our PLCC clips snap onto the leads of surface mounted PLCC packages and provide reliable mechanical and electrical interconnection to all signals. Depending on the specific part, the signals are then presented to one of three interfaces.

### • PLCC - Socket Plugs

The Socket Plugs interconnect two PCB assemblies via a PLCC socket. Our PLCC Socket Plugs, constructed for true PLCC emulation, provide superior connections and eliminate the possibility of damage to the PLCC socket. Depending on the specific part, the signals are connected via through-hole, mini-grid array, SMT with optional alignment pins, or high density, 1.27 mm pin spacing.

### • QFN SMT Feet

These feet provide accurate emulation including e-pad in our exclusive patented design.

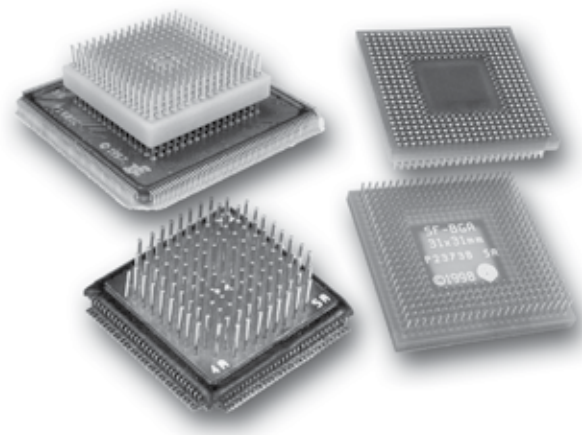

## Giga-snaP™ BGA SMT Adapters - Reliable, Easy to plug, High Speed.

The Giga-snaP™ 1 mm pitch BGA Surface Mount Feet Adapter line of products provide an inexpensive and reliable method for socketing 1mm BGA chips. The product line consists of patent pending female sockets with machined pins epoxy over molded into an assembly that matches a particular BGA pattern. The epoxy over molded female BGA socket is soldered to a PCB using standard soldering methods. A corresponding male pin BGA adapter, to which the user attaches a target BGA chip, is plugged into the female socket on the board and the chip is interconnected and the system is ready to go. The SMT adapters have the same solder ball types as the IC's they are emulating. A complete description and drawings of Giga-snaP™ 1 mm pitch BGA Surface Mount Feet Adapter can be found at: [www.ironwoodelectronics.com/products/adapters/giga\\_snap.cfm](http://www.ironwoodelectronics.com/products/adapters/giga_snap.cfm)

## Benefits

The patent pending over molding method for the adapter results in a much more reliable device. The coefficient of thermal expansion of the BGA SMT foot adapter exactly matches that of the PCB to which it is attached, thus eliminating failures caused by CTE mismatch. Thermal changes from either heat from components or drastic environments will not result in fractured solder ball connections. Secondly the Gig-snaP SMT adapters can be reflowed up to at least 3 times while maintaining full integrity of all solder ball connections. Adapters with pressed

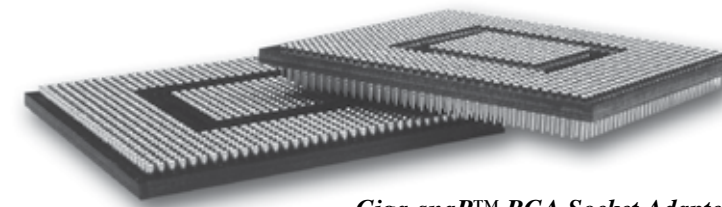

Giga-snaP™ BGA Socket Adapters

pins fracture the substrate and this allows the solder ball to flow up the pin and basically disappear - sometimes on the initial solder attachment. With ball counts exceeding 1000 and approaching more than 2000 there are huge forces when inserting the male device. The force to mate conventional adapters can exceed 80 pounds or 356 Newtons for a 1000 pin device. The Giga-

snaP™ BGA Surface Mount Feet Adapters require less than 1/3 the force of 26 pounds or 115 Newtons for a 1000 pin device. The electrical path of the Giga-snaP™ BGA SMT foot adapters is a high priority performance issue. The physical length from the point where the top connection point on the male adapter to the solder ball on the female is 4.5 mm. This is the shortest connection length by far and therefore providing better transmission of high frequency signals. Ironwood Electronics has the tooling, software, and equipment in place to deliver any array, custom or standard 1 mm Giga-snaP™ in a week or less. Our speed of delivery for BGA SMT adapters is the industry's best. For soldering, see [www.ironwoodelectronics.com/catalog/content/drawings/bsi.pdf](http://www.ironwoodelectronics.com/catalog/content/drawings/bsi.pdf)

## Description of the Giga-snaP™ Epoxy Overmold Adapter

Our patent pending epoxy over mold method for Giga-snaP™ uses FR4 substrate with pins held in place by a thin ring of epoxy holding the pin in place in the FR4 and sealing the pin for the best possible solderability. This solves the PCB fracturing problem and warping caused by press fitting into a substrate. This also allows us to use FR4 rather than plastic and therefore avoiding CTE mismatch.

For drawings -> [www.ironwoodelectronics.com/products/adapters/giga\\_snap.cfm](http://www.ironwoodelectronics.com/products/adapters/giga_snap.cfm)

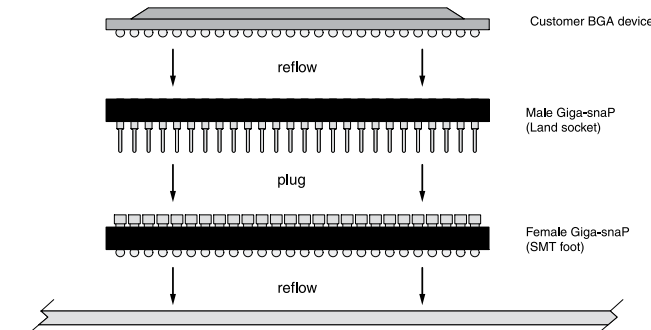

# LS-QFN/MLF

The new high performance SMD Socket Adapters, LS-QFN/MLF, allows user to socket a QFN/MLF chip having only the SMT pads on the target PCB without any additional space for a socket. The companion SF-QFN/MLF is attached directly to the target PCB using the same soldering methods as attaching a QFN/MLF IC. The target IC is soldered to the LS-QFN/MLF. The two parts are interconnected together with gold plated machined pins for highest reliability. The height of the socket not including IC is then 5 mm. This patent pending adapter set then allows easy prototyping or upgrading of QFN/MLF IC's reliably and inexpensively.

For drawings -> [www.ironwoodelectronics.com/products/adapters/smf.cfm](http://www.ironwoodelectronics.com/products/adapters/smf.cfm)

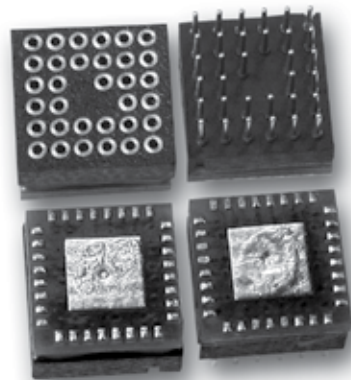
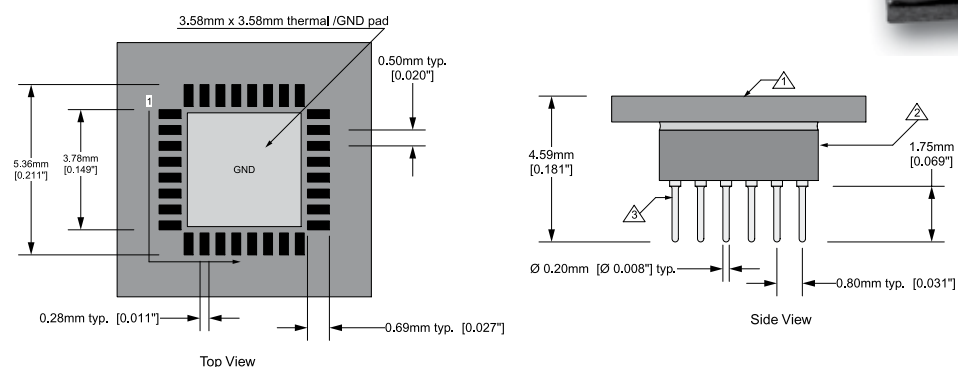

# SF-MLF(QFN)

**Surface Mount Package Emulator Foot** line for range of sizes. These devices use patent pending technology to achieve a reliable and small SMT QFN adapter. The SF-MLF(QFN) have pads on the bottom that precisely match the pin layout for the QFN package including the E-pad or heatsink pad in the center of the pattern. This allows connection to a QFN land pattern of target board to provide a set of interconnects available for probing or connecting to another assembly. The user simply solders the SF-MLF(QFN) using the same solder reflow and attachment methods used for a QFN IC. The SF-MLF(QFN) is the same size as the QFN pin IC in the XY dimension and only 3.3 mm high. The top of the SF-MLF(QFN) after being attached to the target consists of female, machined socket pins with all gold plating for maximum reliability. Compatible gold plated male pin adapters are then plugged in and emulation, probing, or interconnect of the QFN is accomplished.

For drawings -> [www.ironwoodelectronics.com/products/adapters/smf.cfm](http://www.ironwoodelectronics.com/products/adapters/smf.cfm)

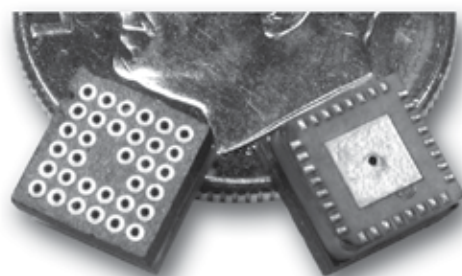
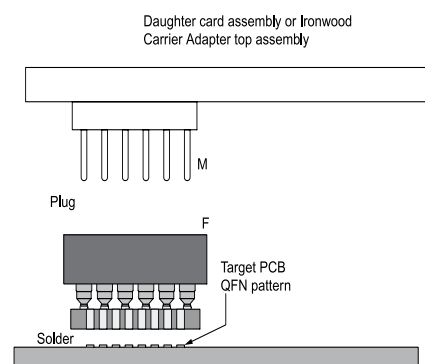
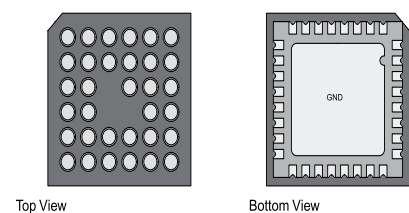

World's smallest SMT Emulator for MLF Connect

# QFP-SMT

**QFP Surface Mount Feet** provide access to QFP surface mount lands on PCBs for the interconnection of upgrade cards, daughter boards or our Probing Adapters and Package Converters. The interconnection is made via a gold plated mini grid array socket.

Visit the web site for the compatible mini grid array socket for each QFP SMT Foot which are listed in the tables.

For drawings -> [www.ironwoodelectronics.com/products/adapters/smf.cfm](http://www.ironwoodelectronics.com/products/adapters/smf.cfm)

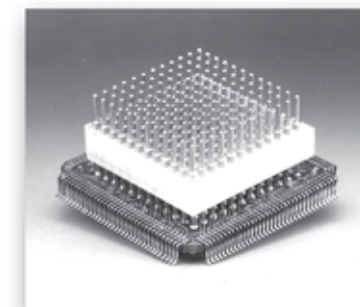
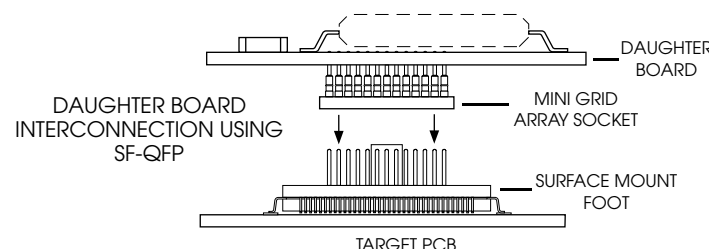

# SOIC-SMT

For drawings -> [www.ironwoodelectronics.com/products/adapters/smf.cfm](http://www.ironwoodelectronics.com/products/adapters/smf.cfm)

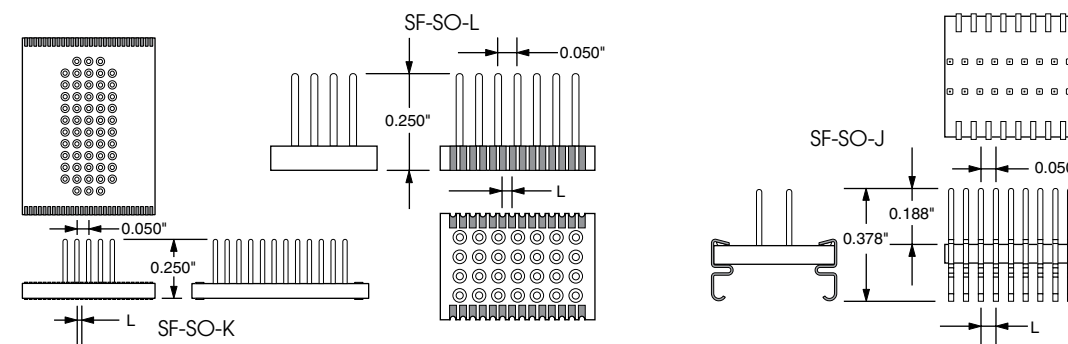

# PLCC-SMT

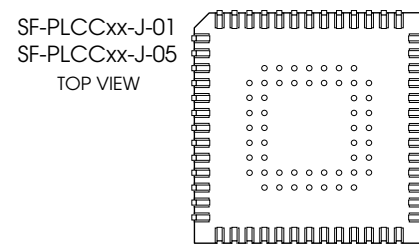

**PLCC Surface Mount Feet** allow access to your target board PLCC land patterns for the interconnection of upgrade cards, daughter boards or our Probing Adapters and Package Converters. For drawings -> [www.ironwoodelectronics.com/products/adapters/smf.cfm](http://www.ironwoodelectronics.com/products/adapters/smf.cfm)

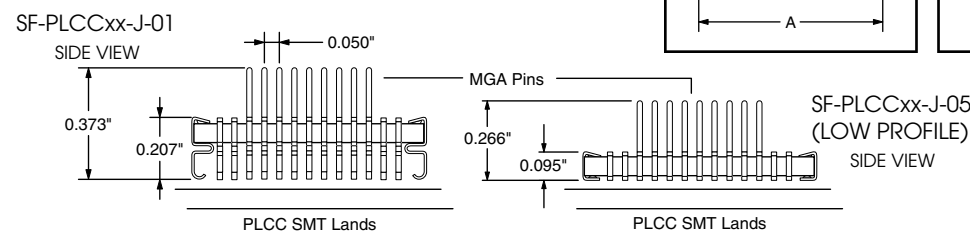
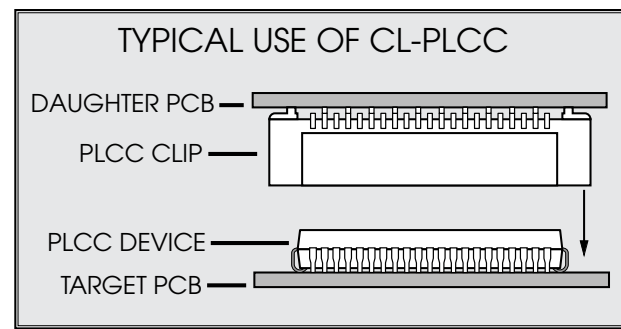

TABLE EXAMPLE:	ORDERING EXAMPLE:
	PLCC PACKAGE CODE
	<b>SF- PLCC20- J- 01</b>
	Pin Count Series Number

# PLCC Clip On Bases & Socket Plugs



## PLCC Clip On Bases

The PLCC clips snap onto the leads of surface mounted PLCC packages and provide reliable mechanical and electrical interconnection to all signals. Depending on the specific part, the signals are then presented to one of three interfaces. The MGA versions can be combined with our PLCC probe board/Probing Adapters. Ironwood part numbers containing “-M” indicate the MGA interface, “-S” the surface mount lands, and “-T” the through hole pin interface.

For drawings -> [www.ironwoodelectronics.com/products/adapters/plcc\\_clips\\_and\\_plugs.cfm](http://www.ironwoodelectronics.com/products/adapters/plcc_clips_and_plugs.cfm)

# Receptacles

Receptacles provide pluggable interface for other packages such as PGA, QIP, QFP, etc. We also offer parts that provide interconnects for in-circuit emulators. Ironwood offers the industry’s widest array of high quality receptacles. Our parts utilize gold plated pins and through-hole connectors exclusively. Please see the web site for more details.

For drawings -> [www.ironwoodelectronics.com/products/adapters/sockets\\_receptacles.cfm](http://www.ironwoodelectronics.com/products/adapters/sockets_receptacles.cfm)

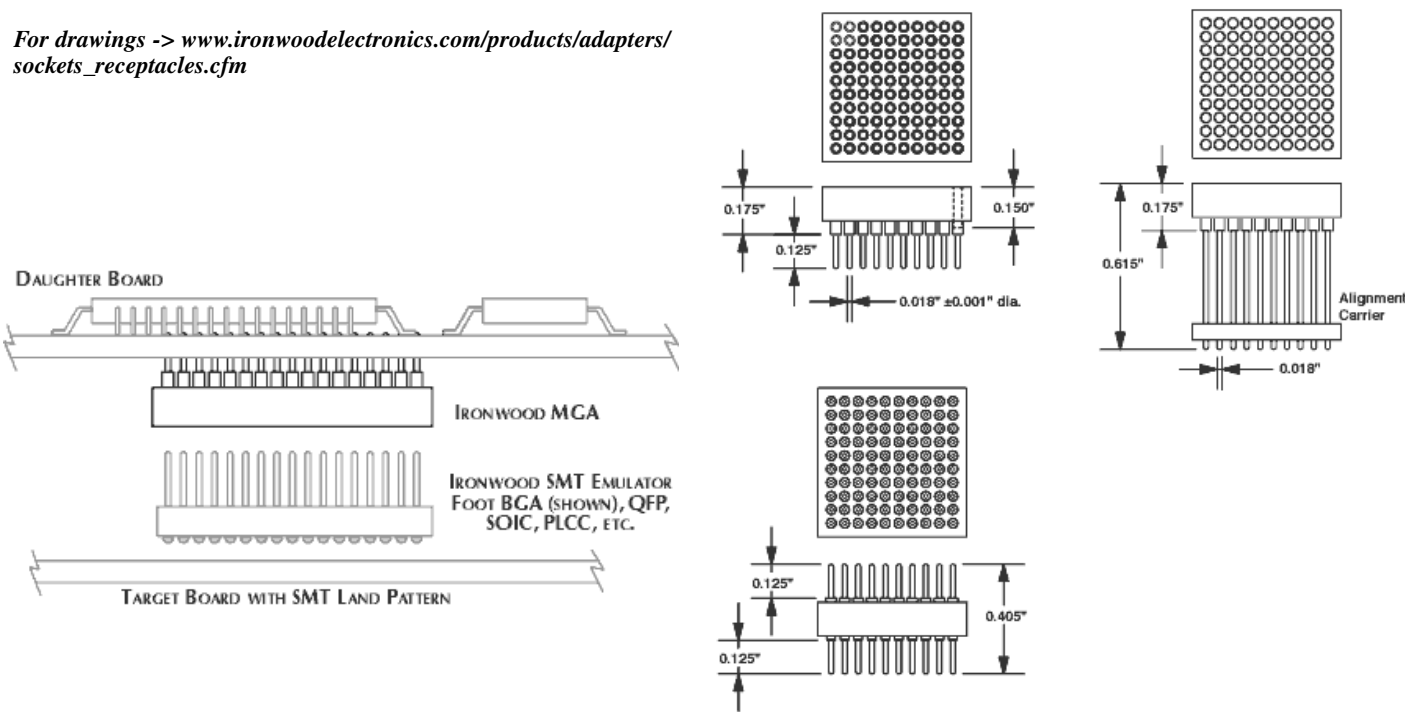

# PLCC Socket Plugs

Our PLCC socket plugs provide superior connections and eliminate the possibility of damage to the PLCC socket. Signals are typically routed to one of five interfaces.

For drawings -> [www.ironwoodelectronics.com/products/adapters/plcc\\_clips\\_and\\_plugs.cfm](http://www.ironwoodelectronics.com/products/adapters/plcc_clips_and_plugs.cfm)



# PLCC Socket Plugs

- Eliminate “Socket Buster” plastic blocks.
- Increase retention forces.

## True J-lead PLCC Emulation Plug

The characteristics one should consider when selecting a PLCC package emulation plug are as follows: a) surface mountable b) durable c) reduced stress on target socket d) true j-lead design and e) retention force. Competitive parts, although less expensive, are typically wirewrap pin on milled block assemblies which do not truly emulate the PLCC package. These ‘block’ designs may overstress the contacts or socket body of a PLCC socket after only a few insertions.

The Ironwood Electronics PLCC plug (the PL-PLCCxx-S-01 part family) has a true j-lead design and can insert into and extract from a PLCC socket several hundred times without harming the socket. The substrate between the j-leads is recessed to allow the ribs of the target PLCC socket to fall between the j-leads. This increases the retention force of the plug in the socket in the right place - The contact between the plugs j-lead and the socket contact and not between the substrate of the plug and the socket body as is the case with low cost, low endurance parts.

A J-lead interface allows the Plug to be surface mounted to a daughter board. The large mass ‘block’ type plugs typically can not be surface mounted. Please visit our website to view the full product line and to download drawings.

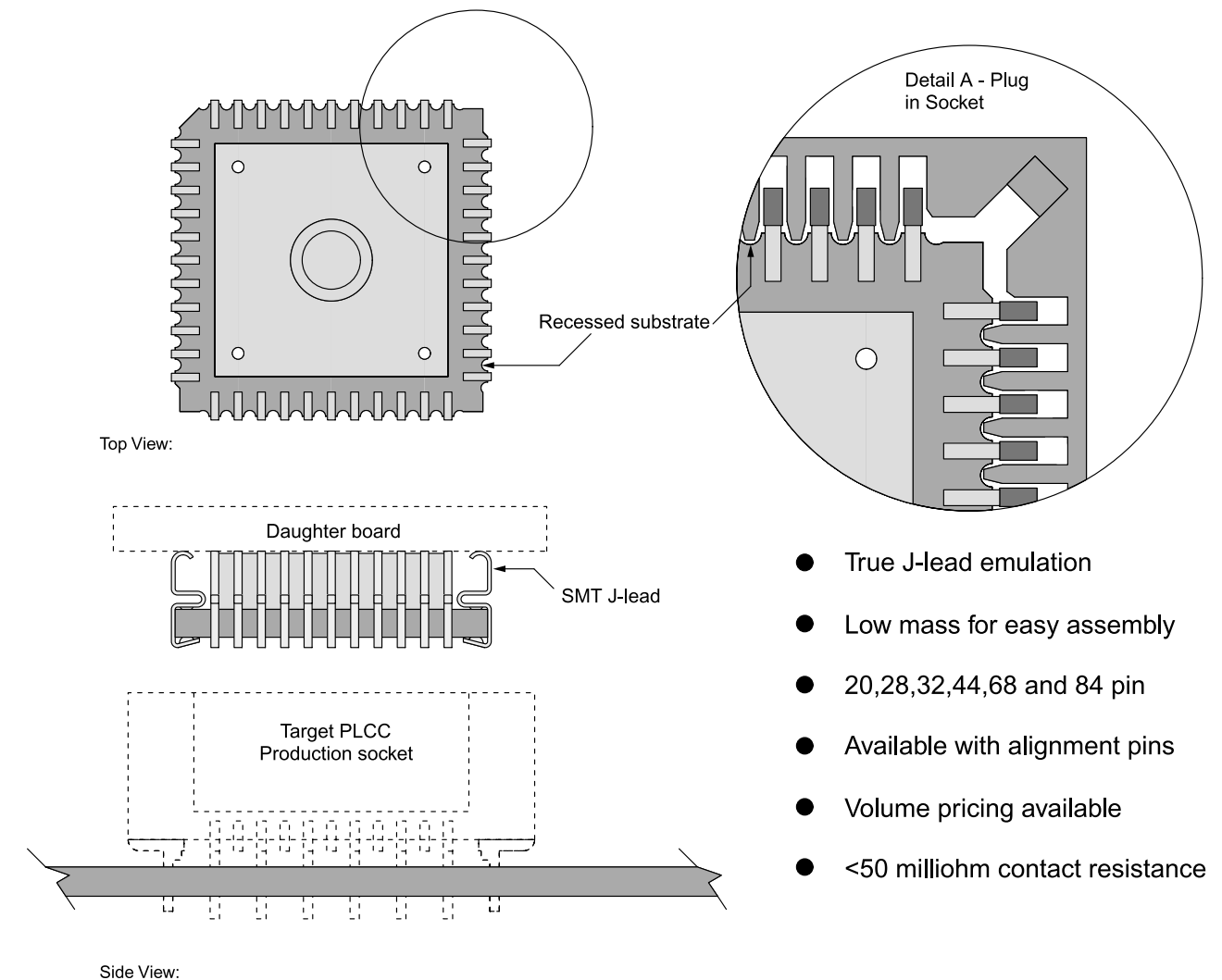

- True J-lead emulation
- Low mass for easy assembly
- 20,28,32,44,68 and 84 pin
- Available with alignment pins
- Volume pricing available
- <50 milliohm contact resistance



## Package converters for production applications quick and cost effective solutions

When a particular IC becomes unavailable or a design change requires an IC upgrade, a package converter is an inexpensive and reliable alternative to respinning large and expensive PCBs. Ironwood Electronics can offer an almost unlimited array of solutions for the conversion of one IC package type to another or from one device type to another (Device converters). Our package converters, like the BGA to QFP converter shown below, are designed with space efficiency and a reduced footprint in mind. The resulting adaptor is typically able to perform with similar electrical characteristics as the original IC package.

Typical Package converter solution

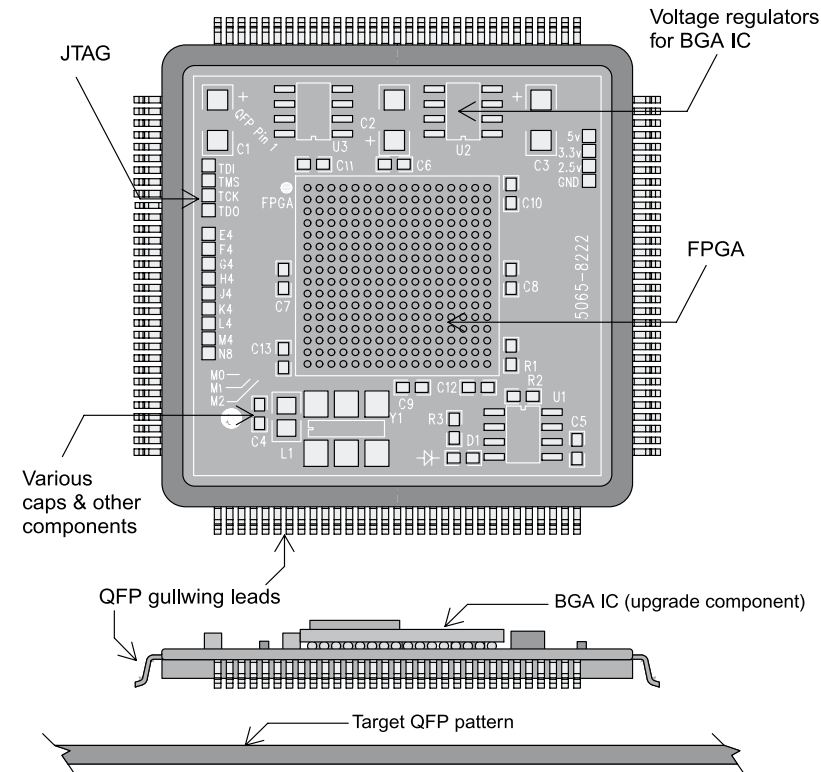

- True target package emulation
- Low mass for easy assembly
- All package types (BGA, QFN/MLF, SOIC, etc.) accommodated
- Tape and Reel or tray packaging available
- Parametric and functional test services available
- Turn key solutions

ISO 9001 Product Development Phase

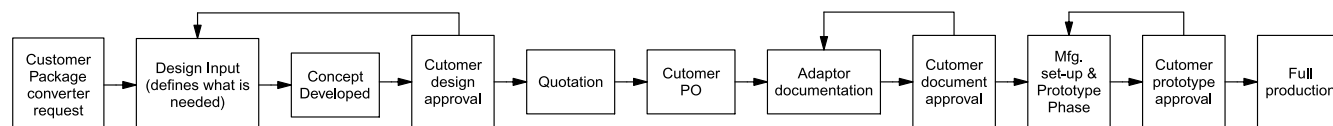

We offer over 500 adapters for converting IC packaging and device pin outs, solving many IC availability and performance issues. We also offer “fix” adapters to solve layout problems and some known chip deficiencies. Custom, quick turn solutions are our speciality.

## Package Converters

Package converters provide an electrical and mechanical conversion from one package type to another. We use gold plated interconnects and pins for our through-hole converters. Ironwood has developed an innovative shaped solder technology for some SMT adapter bases that reduces cost and adds reliability. We offer hundreds of products converting between virtually any two packages: DIP, SDIP, ZIP, PGA, QFP, SOIC, PLCC, BGA, even BGA/CSP.

For drawings -> [www.ironwoodelectronics.com/products/adapters/package\\_converters\\_fix\\_adapters.cfm](http://www.ironwoodelectronics.com/products/adapters/package_converters_fix_adapters.cfm)

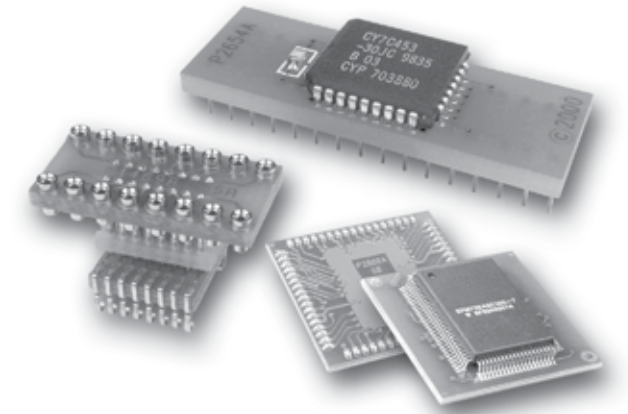

## Probing and Analysis Adapters

We offer probing and logic analyzer adapters for all SMT package types, as well as socket probes for DIP and PLCC. We are Agilent and Tektronix partners. In addition, we offer adapters to facilitate the use of in-circuit emulators and FPGA development systems.

### Probing Adapters - Simplifies system verification

No matter how well designed a circuit is, there is almost always a need to hook up test instruments to it to verify function, look for bugs, or baseline performance. As IC packages become smaller and pin counts grow this becomes harder and harder. Probing adapters are required to alleviate this de-bug problem. Many different types of adapters fall into the test and debug category. The common feature is that they bring the signals of an IC out to a format that is easy to interface with test and analysis equipment.

Various probing adapter list and part drawings can be obtained using the link below:

For drawings -> [www.ironwoodelectronics.com/products/adapters/probing.cfm](http://www.ironwoodelectronics.com/products/adapters/probing.cfm)



# Logic Analyzer Adapters



As qualified Agilent and Tektronix partners, Ironwood Electronics offers adapters for high speed probing with Agilent 16xxx or Tektronix TLA7xx logic analyzers. These adapters incorporate vendor-specific interfaces and controlled impedance signals.

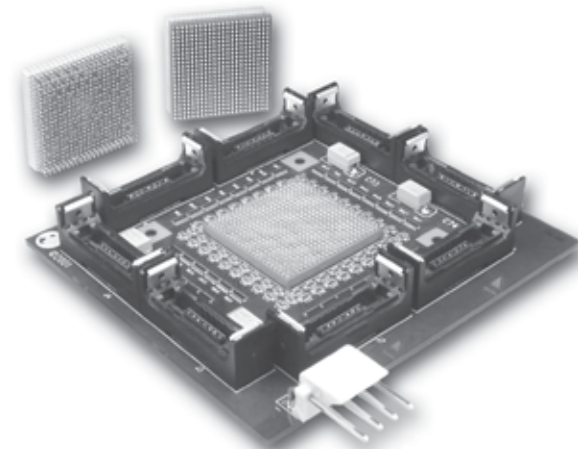

Mounted in place of an IC device, Ironwood's line of logic analyzer adapters eliminate the need to design debug features into target systems. Our modular designs offer the capability to remove the probe connections and choose between using a ZIF socket or one of our fast surface mount land sockets. Real time, high speed analysis of target systems requires excellent signal integrity. Our pluggable components employ gold plated connections. Controlled impedance, vendor specific Mictor connectors are used and each signal's integrity is maintained with high speed as the priority. All of these adapters incorporate high speed PCB design techniques to support state analysis and timing of microprocessors. The drawing highlights a typical three component adapter application: (zif socket, probe board, and SMT foot).

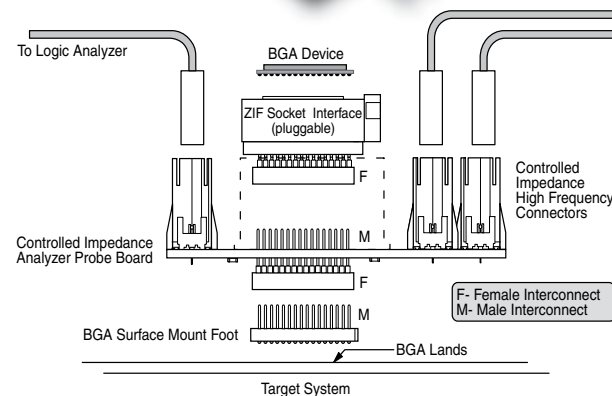

For drawings -> [www.ironwoodelectronics.com/products/adapters/probing\\_adapters/logic\\_analyzer.cfm](http://www.ironwoodelectronics.com/products/adapters/probing_adapters/logic_analyzer.cfm)

# Prototyping Adapters

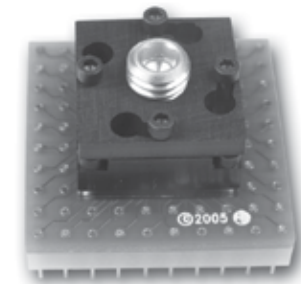

Ironwood Electronics has developed over one thousand prototyping adapter designs, supporting CSP, BGA, QFN, QFP, SOIC, PGA, PLCC, QIP, and DIP packages. We use high quality production and test burn-in sockets for reliable connections. Most popular development panels are supported.

Various probing adapter list and part drawings can be obtained using the link below:

For drawings -> [www.ironwoodelectronics.com/products/adapters/prototyping.cfm](http://www.ironwoodelectronics.com/products/adapters/prototyping.cfm)

An example BGA Prototyping Adapter with clamshell spring pin socket and wire-wrap pins is shown below:

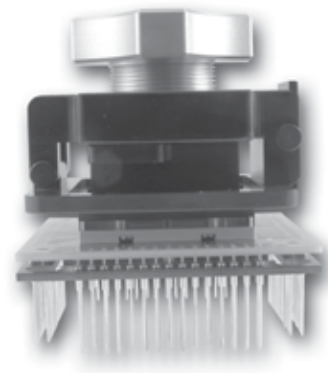

# Turn-Key Capabilities - RoHS Compliant

Fast, high quality, quick turn custom projects are our specialty. We can provide complete turn-key solutions for subsystems and IC upgrades. Complete turn-key solution involves design service, component procurement service, component manufacturing, final assembly, X-ray/AOI service, functional/parametric testing and customized packaging.

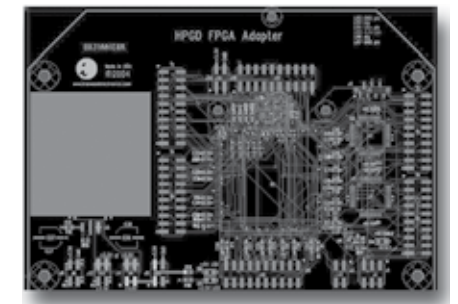

Our in house design service utilizes state-of-the-art PCB/CAD software such as Solidworks 3D modeling, Orcad electrical schematic capture, Pads PCB layout, Pads auto router, CAM 350 etc. 3D modeling of subsystems allows end user to integrate subsystems to their main system board and analyze mechanical constraints, height restriction, etc. before moving towards manufacturing. We take your electrical schematic and generate net list using our Orcad capture software. Then, we use Pads layout software to design the subsystem. We possess knowledge of PCB layout rules for wide variety of components including Ironwood proprietary fine pitch interconnects systems. We use Pads auto router and verify the net list for accuracy. We use DRC (Design Rule Check) for 2nd level verification. Finally, we perform 3rd verification using CAM350 for Gerber data before sent out for fabrication.



We have in-house machining capabilities using best-in-class CNC machines for custom fixture fabrication enabling easy and precise assembly functions. The assembly function starts with screen printing process. We use top of the line DEK solder paste printer that has new camera support arms and a single point release button to reduce set-up time. These cost savings are directly passed on to customers. For more accurate positioning the linear bearing system in the DEK printer ensures smooth, robust motion when aligning the cameras to the PCB. Also we have optimized the process by analyzing variables such as solder paste solution concentration, screen aperture dimensions, squeegee material, squeegee angle and speed. These enable appropriate solder quantity in PCB assembly

without tomb stoning or head in pillow effects, etc.

My Data equipment for pick & place assembly is capable of placing 0201 and the ability to take on all types of high-mix production at low to medium volume. Reduced set up & change over time using lean manufacturing principle enables smooth flow of parts and thus resulting in low cycle time even when the jobs are complex or the batch sizes vary. This means low manufacturing cost for the buyer even when the quantities are low to medium.



After pick& place assembly, the next step is to reflow. This is a critical step where the equipment plays major role in efficiency and process has to be at six sigma level. We have Heller reflow convection oven with 7 zones capable of lead & lead free assembly. Rapid response times and precise temperature controls in the oven assure process uniformity, regardless of component density or board mass, with repeatable profile performance. This means less rejection and high yield which in turn directly reduces bottom line cost. Depending up on no-clean or water soluble flux used in the assembly process, we use EMC batch washer for thorough cleaning to remove any residues.

We use X-rays for verifying BGA solder connection. We use OGP for automatic optical inspection of critical features. We use the CheckSum Model TR-4 Manufacturing Defects Analyzer System to test assemblies to find manufacturing defects such as opens, shorts, and components with incorrect orientation.

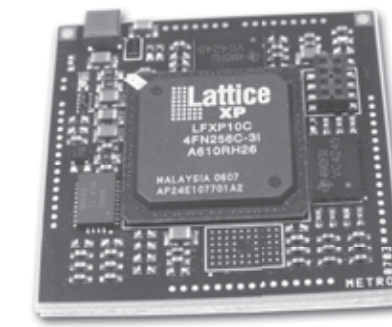

We have custom marking capabilities using laser and serialization options for traceability. We supply parts in panel for further end user assembly requirements. We also have de-panelizer which separates panels into individual unit which then can be packaged in ESD bags, bulk, custom box, tubes, trays and Tape & Reel per customer specification. In a nutshell, we do low to medium volume specialty assembly with best price in town. One of the example solutions we have provided to various customers was shown in the picture.

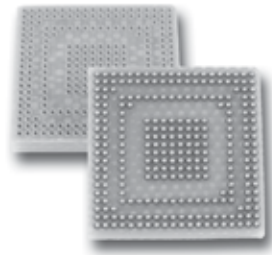

**Chip Size 0.8mm Pitch BGA Socket Adapter for Production Applications**  
*SF-BGA-xxxx is found on pg 18*

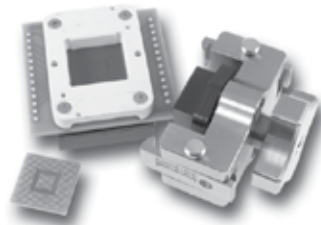

**40 GHz Bandwidth Silver Ball Matrix Elastomer Socket for BGA Packages**  
*SM-BGA-xxxx is found on pg 9*

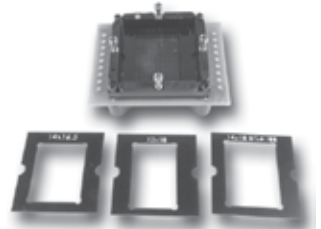

**GHz Bandwidth Wire-in Elastomer Socket for memory modules**  
*SG-BGA-xxxx is found on pg 10*



**10 GHz Bandwidth Wire-in Elastomer Socket for QFN Package**  
*SG-MLF-7079 is found on pg 11*

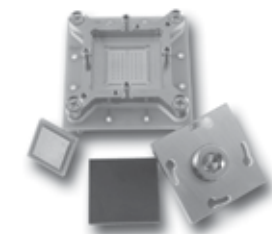

**Production test Stamped Spring Pin Socket for QFN with ePad & manual lid**  
*CBT-QFN-xxxx is found on pg 9*



**Stamped Spring Pin BGA Socket with low profile snap lid**  
*CBT-BGA-xxxx is found on pg 9*

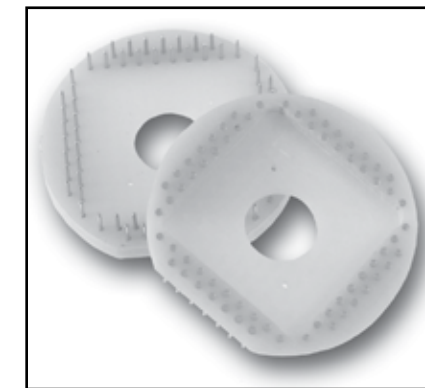

*Giga-snaP Adapters for device/board to board connection*

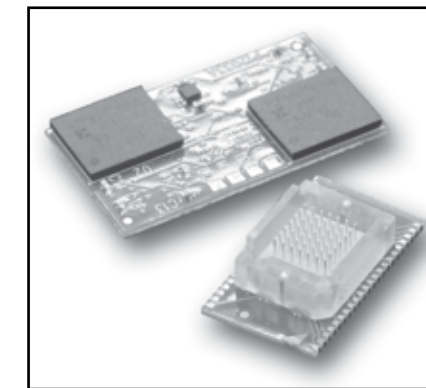

*Daughter card to SOIC Package Converter*

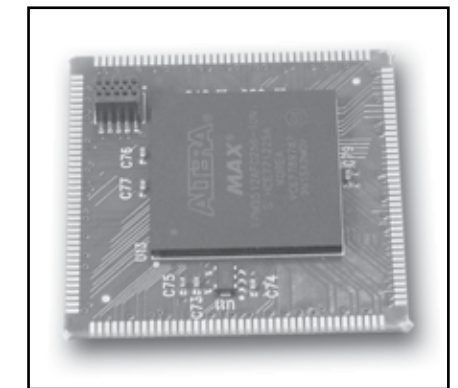

*BGA to QFP Package Converter*

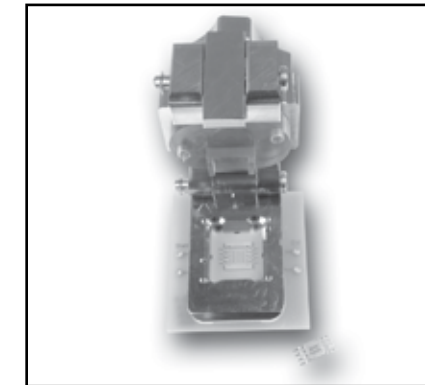

*GHz Socket for SOIC devices*

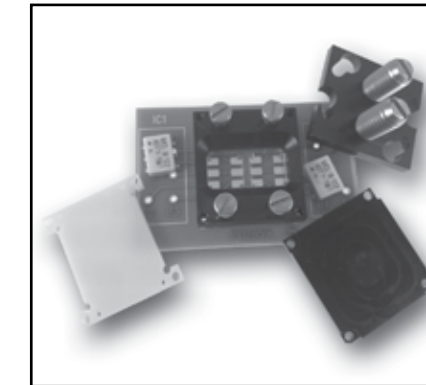

*Dual Site Module Socket with independent compression*

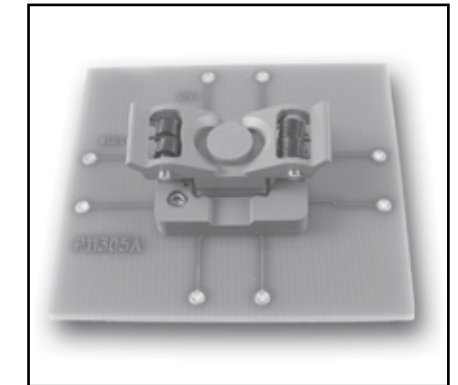

*Low Profile QFN Socket with double latch lid*

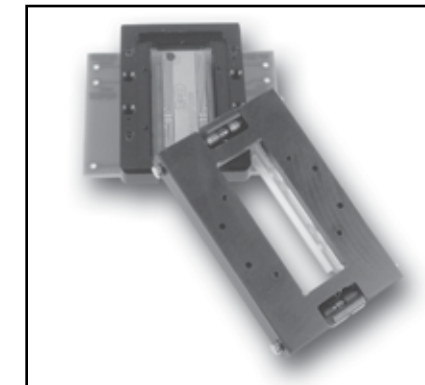

*Open Top GHz Socket*

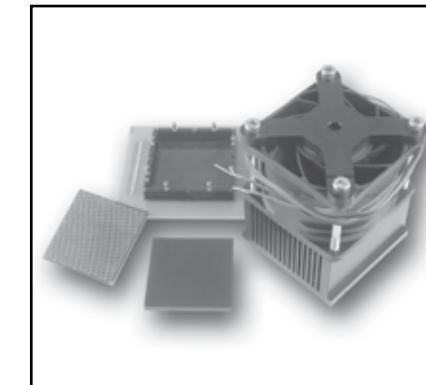

*GHz Socket with heat sink, fan, & SMT Adapter*

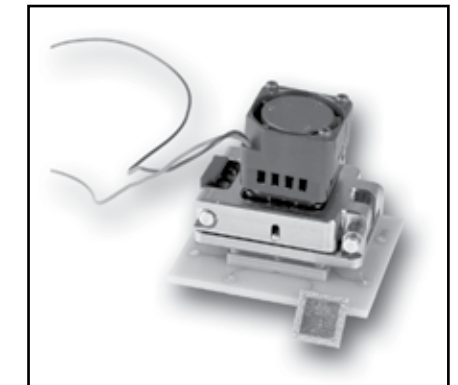

*Stamped Spring Pin Socket with snap lid*

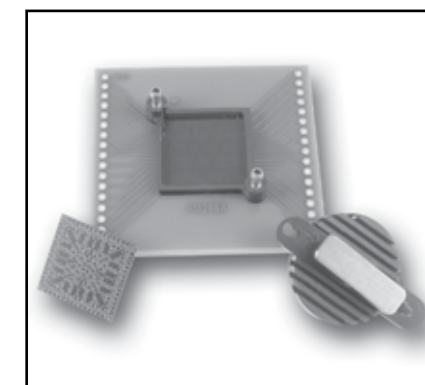

*Two Mounting Hole, GHz Socket*



*Through Hole Adapter for GHz Socket*

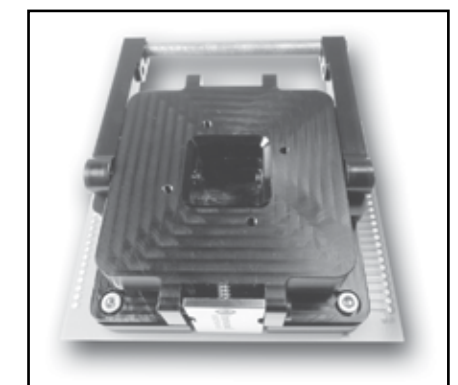

*GHz Socket with lever lid*

## Cross References

Xilinx package to IE GHz socket cross reference  
 Altera package to IE GHz socket cross reference  
 Actel package to IE GHz socket cross reference



For drawings -> [www.ironwoodelectronics.com/cross\\_references.cfm](http://www.ironwoodelectronics.com/cross_references.cfm)

## Patents

8,091,222 Method for forming an adapter apparatus using curable material  
 7,874,880 Adapter apparatus with sleeve spring contacts  
 7,565,843 Packaged device adapter with torque indicating assembly  
 7,368,814 Surface mount adapter apparatus and methods regarding same  
 6,981,882 Packaged device adapter with torque limiting assembly  
 6,877,993 Package device adapter assembly with alignment structure and methods regarding same  
 6,533,589 Packaged device adapter assembly  
 6,394,820 Packaged device adapter assembly and mounting apparatus  
 6,351,392 Offset array adapter



For drawings -> [www.ironwoodelectronics.com/patents.cfm](http://www.ironwoodelectronics.com/patents.cfm)

## Technical Articles

A 20GHz pluggable 0.5mm pitch BGA connector simplifies test/verification  
 IC Socket- Carrier for Semiconductor Devices in Finished Product  
 Functional testing of 0.3mm pitch WLP  
 IC Socket Footprint- Why is it important?  
 Package Converter Compliments Chip Obsolescence  
 3D IC Development Needs Innovative Socket Solution  
 Enhanced interconnect medium simplifies test & verification  
 Role of Sockets in IC Product Life Cycle  
 IC Interconnects for the Life of Your Product  
 S-Parameter Simulation for Sockets & Adapters  
 Chip size IC socket solution for BGA and CSP  
 Methodical Socket Selection Speeds up Time-to-Market for IC Development Projects  
 Optimizing Insertion Extraction Force in a Pin-Socket Interconnect  
 BGA Socket Considerations - Prototype to Reality  
 BGA Socket with Heatsink for High Power Devices  
 Product Life-Cycle White Paper  
 GHz Bandwidth Socket White Paper  
 ISO White Paper  
 DOE relates spring probe variables to signal integrity



For drawings -> [www.ironwoodelectronics.com/technical\\_articles.cfm](http://www.ironwoodelectronics.com/technical_articles.cfm)



## 20 GHz Pluggable 0.5mm Pitch BGA Connector Simplifies Test & Verification

**Ironwood Electronics SFS & LSS BGA Giga-snaP™ socket adapters are chip size footprint that accommodates 0.5mm pitch BGA devices**

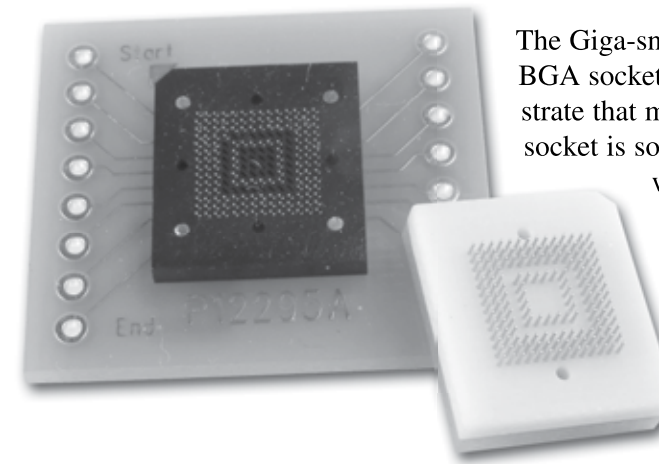

The Giga-snaP™ BGA socket adapter pair consists of patented female BGA sockets with etched pins assembled into high temperature substrate that matches the male pin adapter. The RoHS compliant BGA socket is soldered to a PCB using standard soldering methods without warping which results in reliable connection to PCB. Both BGA socket and adapter are constructed with high temperature polyimide material assuring match with target PCB's and preventing failures that occur due to CTE mismatch. BGA adapter, to which the user attaches a DUT, is plugged into the female BGA socket on the board, thereby chip is interconnected and the system is ready to go.

The BGA socket adapters have the same solder ball types as the IC they are emulating. The Giga-snaP BGA socket adapters require very low insertion and extraction force for ease of operation. The electrical path of the Giga-snaP™ BGA socket adapters is a high priority performance issue with the physical length from the top connection point on the male adapter to the solder ball on the female socket is 3 mm. This is the shortest connection length by far for interconnect pin sockets, therefore providing better transmission of high frequency signals. The Giga-snaP™ BGA socket adapter line is available in many different pin counts/pitches and customs can be delivered in days.

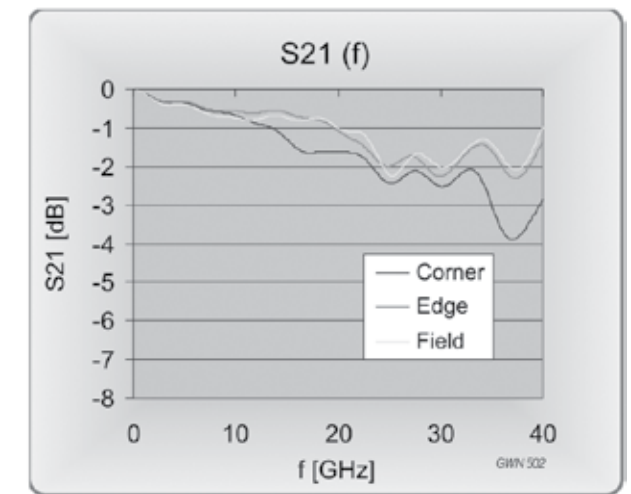

Typical specifications for the 0.5mm SFS/LSS contact technology include:

- Over 20GHz bandwidth @-1dB
- Contact resistance under 20mΩ
- Self inductance under 0.79nH
- Capacitance under 0.088pF
- Operating temperature range -55C to +160C
- Insertion/Extraction life over 100 cycles
- Current rating at ambient is 3 Amps per pin

Visit our web site for technical documents and socket drawings.

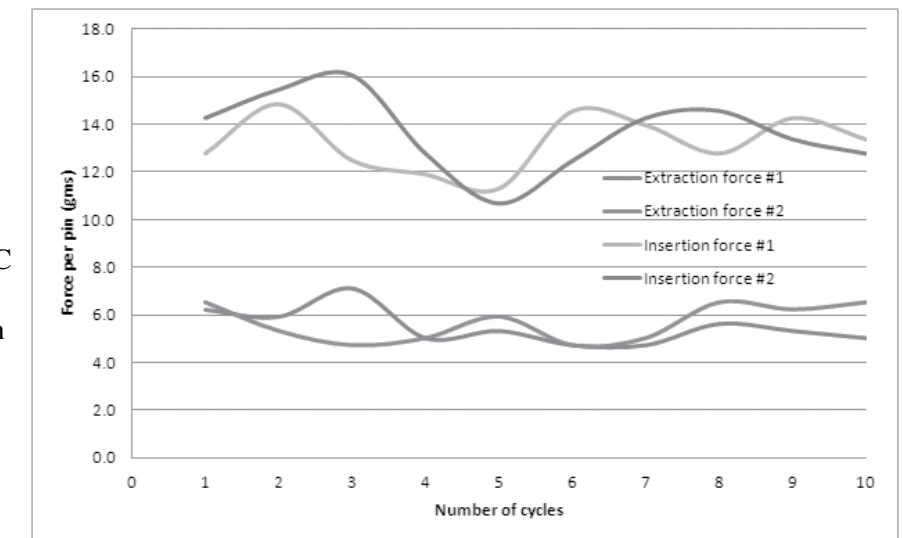



# IC Product Life Cycle - COMPLETE TEST SOLUTION PARTNER

