



## CATALOGUE

# SSL Connector



## Range Overview

### SSL 1.1

#### Board to Board

Right Angle

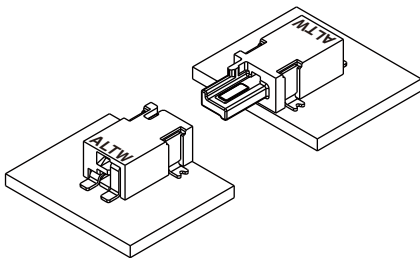

Straight

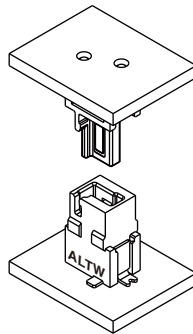

Right Angle & Straight

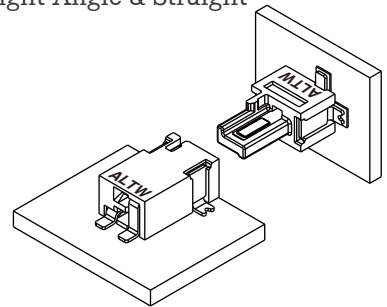

#### Board to Wire

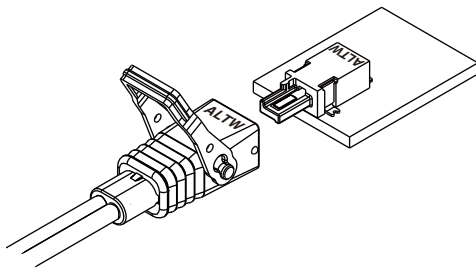

#### Wire to Wire

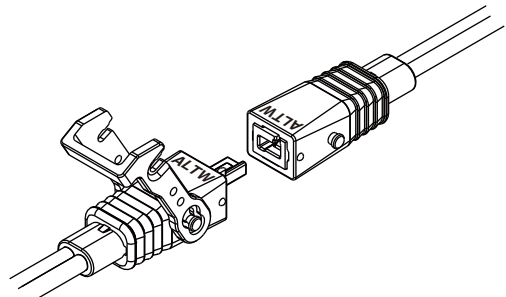

## SSL 1.2

### Wire to Board

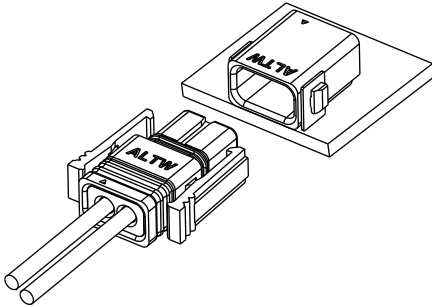

### Wire to Wire

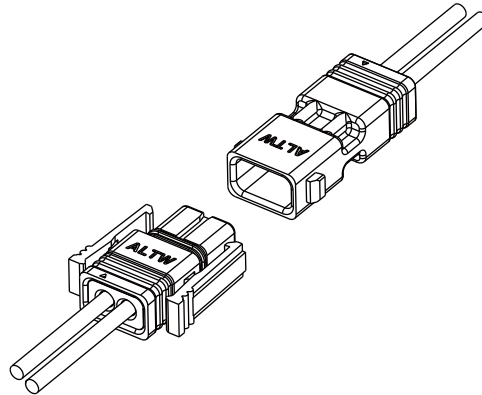

## SSL 1.3 The Bridge

### Jumper

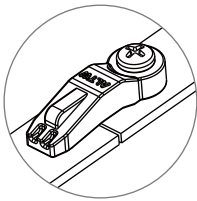

## SSL 2.1 Inverted Thru Board

### Receptacle

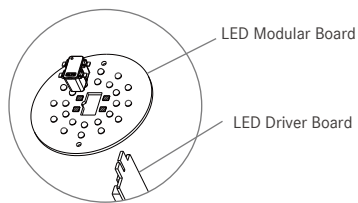
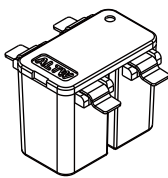

## SSL 2.3 EZ-B for E26/27 Bulb

### Screw Base

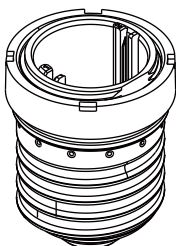

【Note】 Design and specification are subject to change without notice.

## Specification | SSL 1.1

<b>Identifications</b>	SSL 1.1 DC Connector
<b>Description</b>	Board to Board Board to Wire Wire to Wire
<b>Current Rating / Data</b>	3A per pin (2, 4 & 6 pins available)
<b>Voltage Rating</b>	Max100 VAC / VDC
<b>Material</b>	Contact: Copper Alloy, Tin over Nickel Housing: Thermoplastic, UL 94V-0 Rated Hood: Thermoplastic, UL 94V-0 Rated Lock: Nylon (PA66), UL 94V-0 Rated SR: PP, UL 94V-0 Rated. UL recognized wire & flat cable available
<b>Temperature Range</b>	PCB Mount: -40°C ~ +105°C Wire Assemblies: -40°C ~ +100°C
<b>Contact Resistance</b>	≤ 20m Ω
<b>Insulation Resistance</b>	≥ 1000m Ω at 250VDC
<b>Durability</b>	100 cycles
<b>Breakdown Voltage</b>	1200 V AC
<b>More to know</b>	UL1977 / cUL / CSA C22.2

# Ordering Information | SSL 1.1

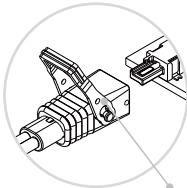
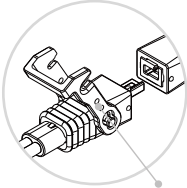
1	2	3	4	5	6	7	8
<b>Connector Series</b> (11) SSL 1.1 None Waterproof Series							
<b>Connector (Housing) Gender</b> (J) Jack (P) Plug							
<b>Number of Contacts</b> 2,4, 6 contacts EX. (2) = 2 Contacts							
<b>Connector Type</b> > For PCB Mount Type (A) SMT Board Straight with Post (C) SMT Board Right Angle with Post (D) SMT Board Right Angle without Post > For Wire Assembly (L) Wire Assembly, Straight, With SR							
<b>Wires Assembly Options</b> > For PCB Mount Type (00) For PCB Mount Type > For Wire Assembly (2J) 2-End Jack Connector (2P) 2-End Plug Connector (JP) End 1: Jack, End 2: Plug, (JO) End 1: Jack, End 2: Open (PO) End 1: Plug, End 2: Open							
<b>Lock Option</b> (O) None (Without Lock) (B) W2B Lock in End 1 (W) W2W Lock in End 1 (D) With Two W2B Lock (T) With Two W2W Lock (S) W2B Lock in End 1, W2W Lock in End 2							
 <p>Wire to Board Lock (W2B Lock)</p>				 <p>Wire to Wire Lock (W2W Lock)</p>			
<b>Wire Size</b> > For PCB Mount Type (00) Applicable for SMT Board > For Wire Assembly (22) 22 AWG							

Wire Assembly / Wires Type

> For PCB Mount Type  
 (001), (002).....  
 Without Wire : Different Versions

> For Wire Assembly  
 (□)+(■) : Wire Type + Length  
 EX. (A01) = Wire + 10cm  
 (□) : Wire Type  
 (A) UL recognized wire  
 (D) UL recognized flat cable  
 (■) : Length  
 From 100mm~9900mm  
 EX. (01) = 100mm, (02) = 200mm, (03) = 300mm .....  
 \*Every 100mm as per extension

[Note] Design and specification are subject to change without notice.

# Physical Dimension | SSL 1.1

## ▾ PCB Mount > Right Angle

>> 2P

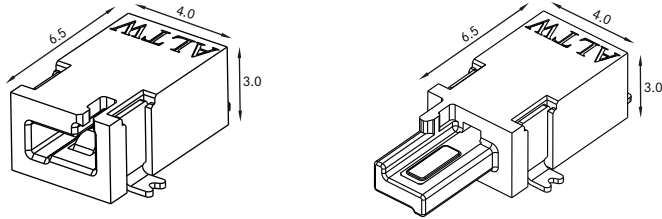

Recommended PCB Layout

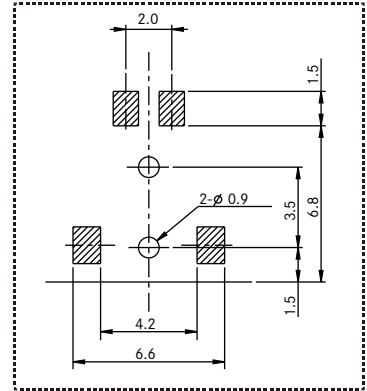

Unit: mm

>> 4P

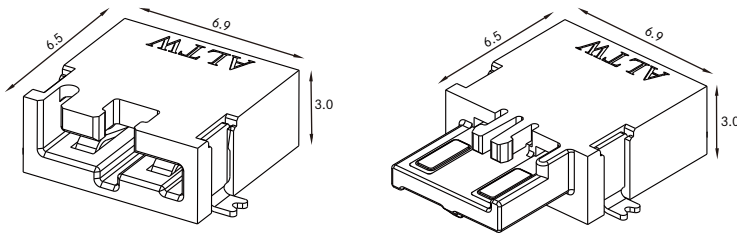

Recommended PCB Layout

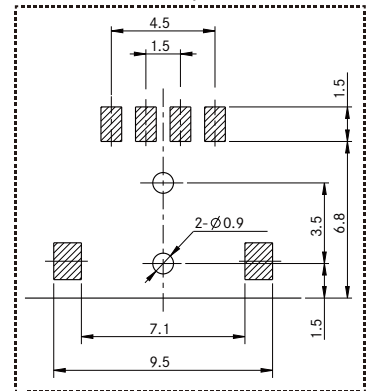

Unit: mm

>> 6P

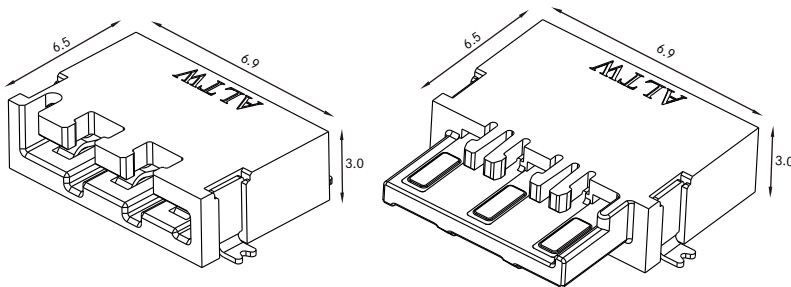

Recommended PCB Layout

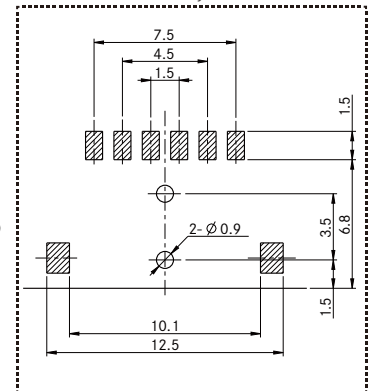

Unit: mm

▾ PCB Mount > Straight

>> 2P

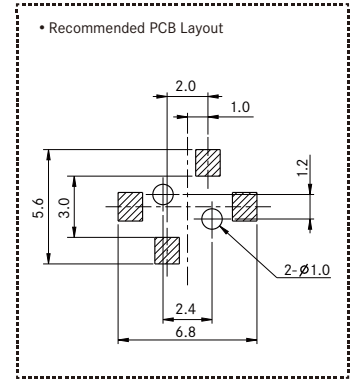
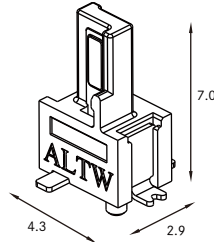
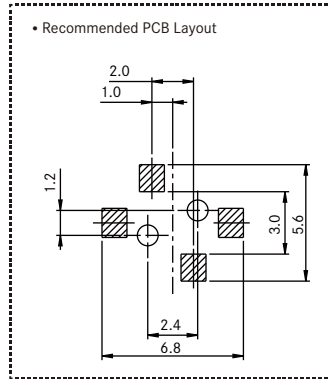
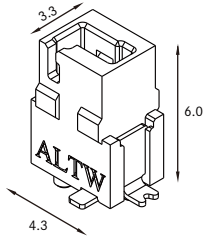

Unit: mm

>> 4P

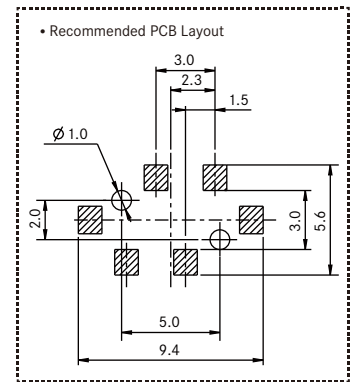
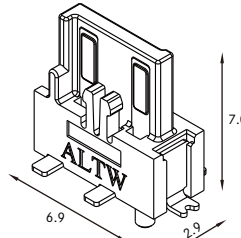
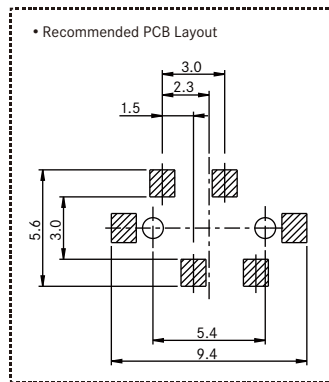
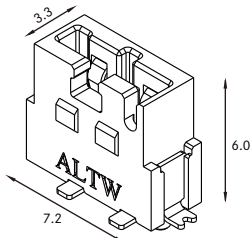

Unit: mm

>> 6P

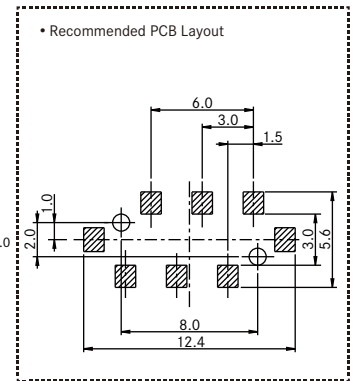
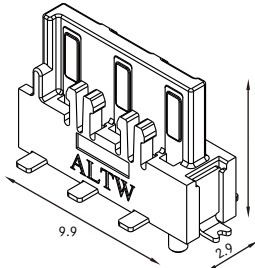
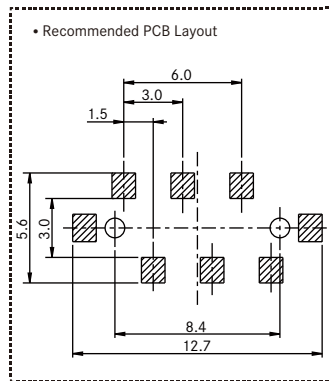
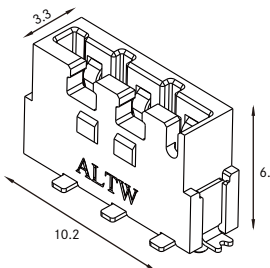

Unit: mm

【Note】 Design and specification are subject to change without notice.

## Wire Assembly

>> Flat Cable

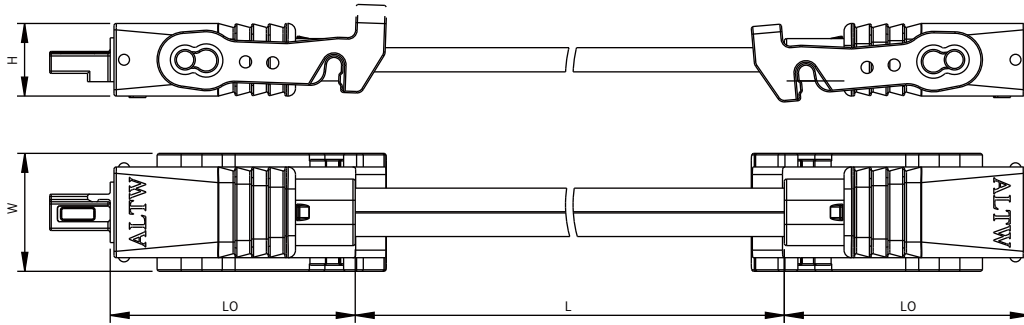

>> Wire

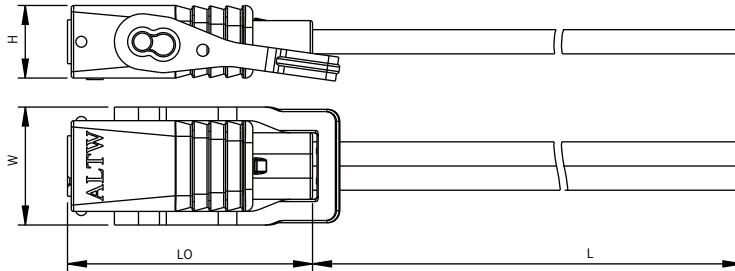

	L0	H	W	Cable Length (L)
2P	18.2	4.8	7.8	Various cable length available upon request
4P	18.2	4.8	11.2	
6P	18.2	4.8	14.2	

Unit: mm

## Find Our Standard Products | SSL 1.1

### Board to Board > Right Angle

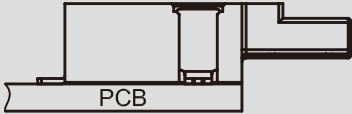
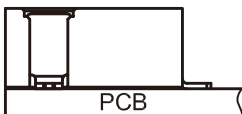
	 <p>4 PCB Mount (Right Angle) ; With post (C) or without post (D)</p>	 <p>4 PCB Mount (Right Angle) ; With post (C) or without post (D)</p>
	Plug	Jack
2P	SSL11-P 2 4 00-000001	SSL11-J 2 4 00-000001
4P	SSL11-P 4 4 00-000001	SSL11-J 4 4 00-000001
6P	SSL11-P 6 4 00-000001	SSL11-J 6 4 00-000001

### Board to Board > Straight

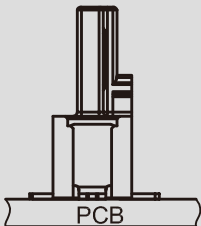
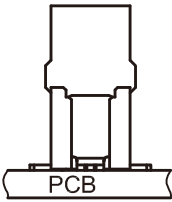
		
	Plug	Jack
2P	SSL11-P2A00-000001	SSL11-J2A00-000001
4P	SSL11-P4A00-000001	SSL11-J4A00-000001
6P	SSL11-P6A00-000001	SSL11-J6A00-000001

【Note】 Design and specification are subject to change without notice.



### Board to Board > Right Angle & Straight

<p>4 PCB Mount (Right Angle) : With post (C) or without post (D) PCB Mount (Straight) : With post (A)</p> <p>4 PCB Mount (Right Angle) : With post(C) or without post (D) PCB Mount (Straight) : With post (A)</p>		
	Plug	Jack
<b>2P</b>	SSL11-P 2 4 00-000001	SSL11-J 2 4 00-000001
<b>4P</b>	SSL11-P 4 4 00-000001	SSL11-J 4 4 00-000001
<b>6P</b>	SSL11-P 6 4 00-000001	SSL11-J 6 4 00-000001

### Board to Wire

<p>4 PCB Mount (Right Angle) ; With post (C) or without post (D)</p>		<p>*XX: Various cable length available upon request</p>			
	Mount Type		End 1 + End 2	Cable Type	Part Number
<b>2P</b>	Right Angle Plug	SSL11-P2 4 00-000001	Jack + Open End	Wire	SSL11-J2LJ0-B22A <u>XX</u> *
<b>4P</b>		SSL11-P4 4 00-000001			SSL11-J4LJ0-B22A <u>XX</u> *
<b>6P</b>		SSL11-P6 4 00-000001			SSL11-J6LJ0-B22A <u>XX</u> *

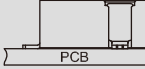
### Board to Wire





4 PCB Mount (Right Angle) ; With post (C) or without post (D)



\*XX: Various cable length available upon request

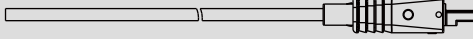
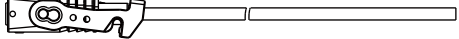

	Mount Type	Jack	End 1 + End 2	Cable Type	Part Number
2P	Right Angle Jack	SSL11-J2 4 00-000001	Plug + Open End	Wire	SSL11-P2LP0-B22AXX*
4P		SSL11-J4 4 00-000001			SSL11-P4LP0-B22AXX*
6P		SSL11-J6 4 00-000001			SSL11-P6LP0-B22AXX*

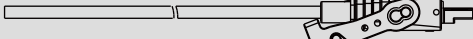
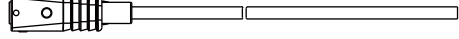
### Wire to Wire

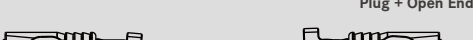
\*XX: Various cable length available upon request

Cable Type	Contacts 3	End 1 + End 2	Lock	Part Number	End 1 + End 2	Lock	Part Number
Wire	2, 4, 6	Plug + Open End	No Lock	SSL11-P 3 LP0-022AXX*	Jack + Open End	One Lock	SSL11-J 3 LJ0-022AXX*
			One Lock	SSL11-P 3 LP0-W22AXX*		No Lock	SSL11-J 3 LJ0-022AXX*
Flat Cable	2, 4, 6	Plug + Jack	Two Locks	SSL11-P 3 LJP-T22DXX*	Jack + Plug	No Lock	SSL11-P 3 LJP-022DXX*
		Plug + Plug	Two Locks	SSL11-P 3 L2P-T22DXX*	Jack + Plug	No Lock	SSL11-J 3 L2J-022DXX*
			No Lock	SSL11-P 3 L2P-022DXX*		No Lock	SSL11-J 3 L2J-T22DXX*

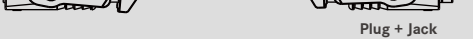
[Note] Design and specification are subject to change without notice.

## Specification | SSL 1.2

<b>Identifications</b>	SSL 1.2 DC Connector (IPX8 Waterproof Series)
<b>Description</b>	Board to Wire Wire to Wire
<b>Current Rating / Data</b>	5A per pin (2 & 4 pins available; 6 pins upon request)
<b>Material</b>	Terminal: Copper alloy, tin plated Housing: Thermoplastic, UL94V-0 Rated Seal&Gasket: Silicone
<b>Waterproof Rating</b>	IP68, 1M depth of water in 24 hours
<b>Temperature Range</b>	-40°C ~ +105°C
<b>Contact Resistance</b>	≤ 20m Ω
<b>Insulation Resistance</b>	≥ 1000M Ω at 500VDC
<b>Durability</b>	30 cycles
<b>Breakdown Voltage</b>	1500V AC
<b>More to know</b>	UL1977 / cUL / CSA C22.2

# Ordering Information | SSL 1.2

<b>Connector Series</b>		<b>1</b> — <b>2</b> <b>3</b> <b>4</b> <b>5</b> <b>6</b> <b>7</b> <b>8</b>
(12) SSL 1.2 IPX8 Waterproof Series		
<b>Connector (Housing) Gender</b>		
(J) Jack	(P) Plug	
<b>Number of Contacts</b>		
2, 4 contacts		
EX. (2) = 2 Contacts		
<b>Connector Type</b>		
<u>&gt; For PCB Mount Type</u>		<u>&gt; For Cable</u>
(D) SMT Board Right Angle without Post	(L) Cable Assemblies, Straight	(F) Field Installable
<b>Wires Assembly Options</b>		
<u>&gt; For PCB Mount Type</u>		<u>&gt; For Cable</u>
(00) Applicable for PCB Mount Type	(2J) Cable with 2-Ends Jack Connector	(2P) Cable with 2-Ends Plug Connector
	(JP) One End: Jack, Another End: Plug,	(JO) End 1: Jack , End 2: Open
	(PO) End 1: Plug, End 2: Open	
<b>Latch Option</b>		
(0) None latch		
(M) with latch		
<b>Wire Size</b>		
<u>&gt; For PCB Mount Type</u>		<u>&gt; For Cable</u>
(00) Applicable for PCB Mount Type		(20) 20 AWG
<b>Cable / Wires Type</b>		
<u>&gt; For PCB Mount Type</u>		<u>&gt; For Cable</u>
(001), (002).....		(□)+(■) : Cable Type + Cable Length
Without Cable : Different Versions		EX.(A01)= UL1430 Cable + 100mm
	(□) : Cable Type	(A) Wires, UL 1430 (Approved)
	From 100mm~9900mm	EX. (01), (02) = 200mm, (03) = 300mm .....
	*Every 100mm as per extension	

[ Note ] Design and specification are subject to change without notice.

# Physical Dimension | SSL 1.2

## ▾ SMT Receptacle

>> 2P

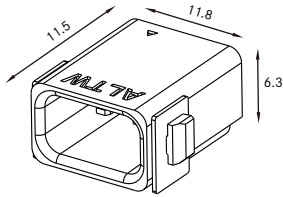

Recommended PCB Layout

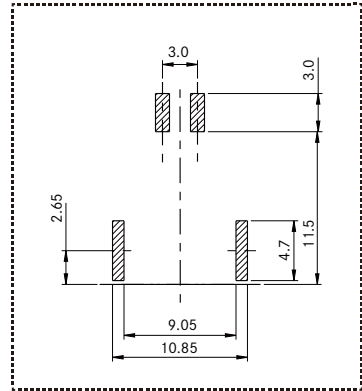

Unit: mm

>> 2P

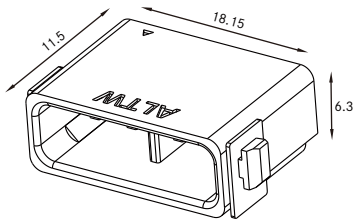

Recommended PCB Layout

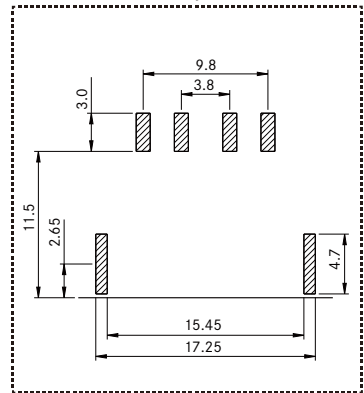

Unit: mm

## ▾ Cable Assemblies & Field Installable

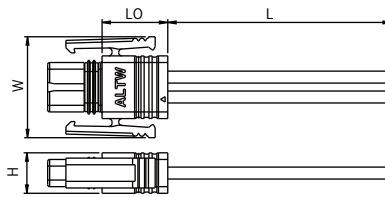
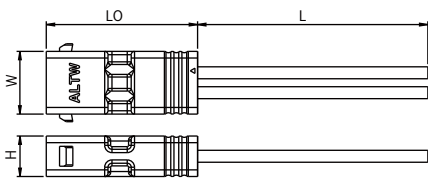

\* Various cable length available upon request.

## ▾ Cable Assemblies & Field Installable

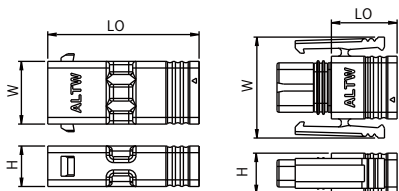

	Gender	L0	H	W
2P	Jack	22.8	6.1	11.8
	Plug	18.1	6.1	15.2
4P	Jack	22.8	6.1	18.15
	Plug	9.9	6.1	21.2

Unit: mm

## Find Our Standard Products | SSL 1.2

### Board to Wire

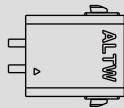
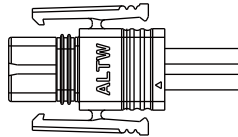
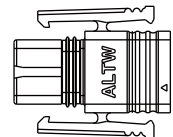
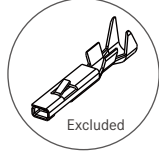
		 <p>Cable Assemblies</p>		 <p>Field Installable</p>		 <p>Excluded</p> <p>BBA00010667</p>
		Jack		Plug		
2P	SSL 12-J2D00-000001	SSL 12-P2LP0-M20AXX*	SSL 12-P2FP0-M00001			
4P	SSL 12-J4D00-000001	SSL 12-P4LP0-M20AXX*	SSL 12-P4FP0-M00001			

\*XX: Various cable length available upon request

### Wire to Wire

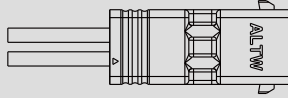
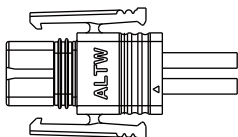
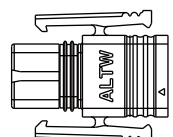
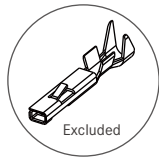
 <p>Cable Assemblies</p>		 <p>Cable Assemblies</p>		 <p>Field Installable</p>		 <p>Excluded</p> <p>BBA00010667</p>
		Jack		Plug		
2P	SSL 12-J2 ④ J0-020AXX*	SSL 12-P2LP0-M20AXX*	SSL 12-P2FP0-M00001			
4P	SSL 12-J4 ④ J0-020AXX*	SSL 12-P4LP0-M20AXX*	SSL 12-P4FP0-M00001			

④ Choose the connector type:  
Cable Assemblies (L) or Field Installable (F)

\*XX: Various cable length available upon request

### Accessories > Contacts

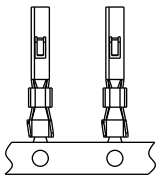
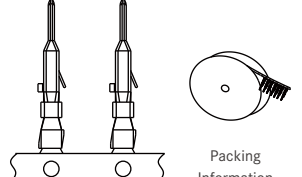
	 <p>Packing Information</p>	 <p>Packing Information</p>
Part Number	BBA00010666	BBA00010667

【Note】 Design and specification are subject to change without notice.

## Specification | SSL 1.3

<b>Identifications</b>	SSL1.3 The Bridge
<b>Description</b>	Board to Board Jumper
<b>Number of Position</b>	1P
<b>Current Rating / Data</b>	5A
<b>Voltage Rating</b>	500V AC/DC
<b>Material</b>	Terminal: Copper Alloy, Gold (selective) over Nickel Plated Housing: Thermoplastic, UL94V-0 Rated
<b>Temperature Range</b>	-40°C ~ +105°C
<b>Contact Resistance</b>	$\leq 20\text{m } \Omega$
<b>Insulation Resistance</b>	$\geq 1000\text{M } \Omega$ at 500VDC
<b>Durability</b>	10 cycles
<b>Breakdown Voltage</b>	2000V AC

## Ordering Information | SSL 1.3

### Connector Series

(13) SSL 1.3 The Bridge Series

SSL1.3-D-1-S-00-0-00-001

### Connector (Housing) Gender

(D) no gender

### Number of Contacts

1 contacts

EX. (1) = 1 Contacts

### Connector Type

> For PCB Mount Type

(S) Screw Mount Type

### Wires Assembly Options

> For PCB Mount Type

(00) Applicable for PCB Mount Type

### Assembly Option

(0) Applicable for PCB Mount Type

### Wire Size

> For PCB Mount Type

(00) Applicable for PCB Mount Type

【Note】 Design and specification are subject to change without notice.

# Physical Dimension | SSL 1.3

## ▾ SMT Receptacle

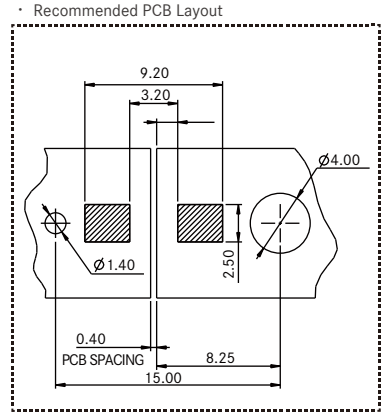
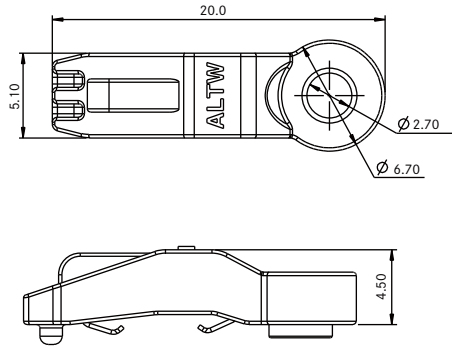

Unit: mm

## Find Our Standard Products | SSL 1.3

### ∨ SSL 1.3 The Bridge

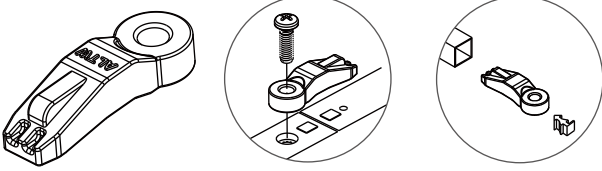
	
Part Number	SSL13-D1S00-000001

【Note】 Design and specification are subject to change without notice.

## Specification | SSL 2.1

<b>Identifications</b>	SSL2.1 Inverted Thru Board
<b>Description</b>	Board to Board
<b>Number of Position</b>	2P
<b>Current Rating / Data</b>	12A
<b>Voltage Rating</b>	600V AC/DC
<b>Material</b>	Terminal: Copper Alloy, Gold Plated, Nickel-under Plated All over Housing & Cover: Thermoplastic, UL94V-0 Rated
<b>Temperature Range</b>	-40°C ~ +105°C
<b>Contact Resistance</b>	≤ 20m Ω
<b>Insulation Resistance</b>	≥ 1000M Ω at 500VDC
<b>Durability</b>	20 cycles
<b>Breakdown Voltage</b>	2200V AC
<b>More to know</b>	UL1977 / cUL / CSA C22.2 / RoHS

# Ordering Information | SSL 2.1

## Connector Series

SSL2.1-J-2-E-00-0-00-001

(21) SSL 2.1 Inverted Thru Hole

## Connector (Housing) Gender

(J) Jack

## Number of Contacts

2 contacts

EX. (2) = 2 Contacts

## Connector Type

> For PCB Mount Type

(E) SMT Inverted 180 degree type

## Wires Assembly Options

> For PCB Mount Type

(00) Applicable for PCB Mount Type

## Assembly Option

(0) Applicable for PCB Mount Type

## Wire Size

> For PCB Mount Type

(00) Applicable for PCB Mount Type

【Note】 Design and specification are subject to change without notice.

# Physical Dimension | SSL 2.1

## ▾ SMT Receptacle

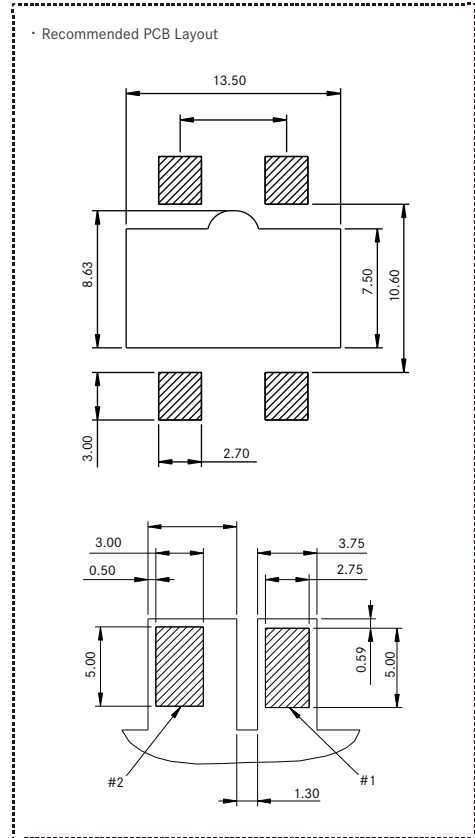
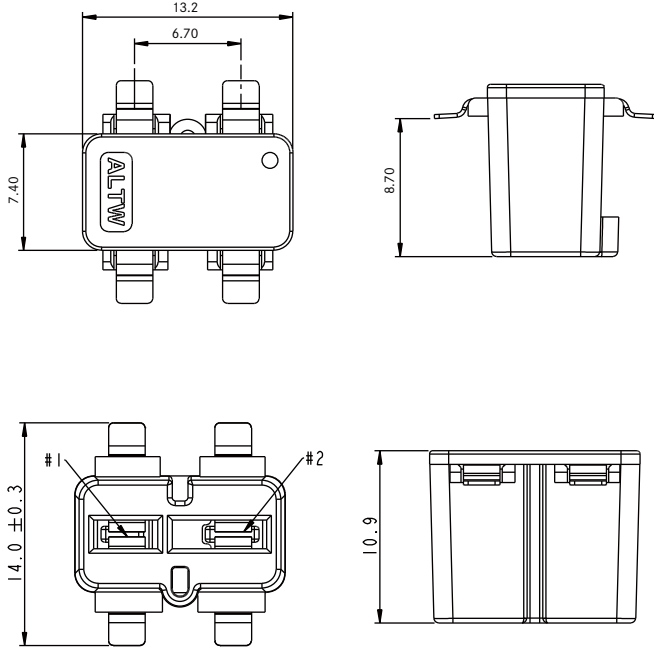

Unit: mm

## Find Our Standard Products | SSL 2.1

### ∨ SSL 2.1 Inverted Thru Board

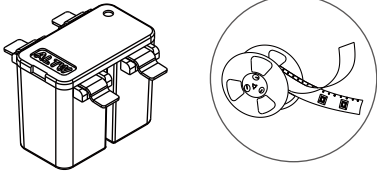
	
Part Number	SSL21-J2E00-000001

【Note】 Design and specification are subject to change without notice.

## Specification | SSL 2.3

<b>Identifications</b>	SSL2.3 EZ-B
<b>Description</b>	Screw Base for E26/27 Bulb
<b>Current Rating / Data</b>	3A
<b>Voltage Rating</b>	500V AC/DC
<b>Material</b>	Terminal: Copper Alloy, Gold Plated, Nickel-under Plated All over Housing & Cover: Thermoplastic, UL94V-0 Rated
<b>Temperature Range</b>	-40°C ~ +105°C
<b>Contact Resistance</b>	≤ 20m Ω
<b>Insulation Resistance</b>	≥ 1000M Ω at 500VDC
<b>Durability</b>	100 cycles
<b>Breakdown Voltage</b>	2000V AC
<b>More to know</b>	UL1977 / cUL / CSA C22.2 / RoHS

## Ordering Information | SSL 2.3

### Connector Series

SSL2.3 - D - 2 - S - 00 - 0 - 00 - 001

(23) SSL 2.3 EZ-Base

### Connector (Housing) Gender

(D) No Gender

### Number of Contacts

2 contacts

EX. (2) = 2 Contacts

### Connector Type

> For PCB Mount Type

(S) Screw Mount Type

### Wires Assembly Options

> For PCB Mount Type

(00) Applicable for PCB Mount Type

### Assembly Option

(0) Applicable for PCB Mount Type

### Wire Size

> For PCB Mount Type

(00) Applicable for PCB Mount Type

【Note】 Design and specification are subject to change without notice.

# Physical Dimension | SSL 2.3

## ▾ SMT Receptacle

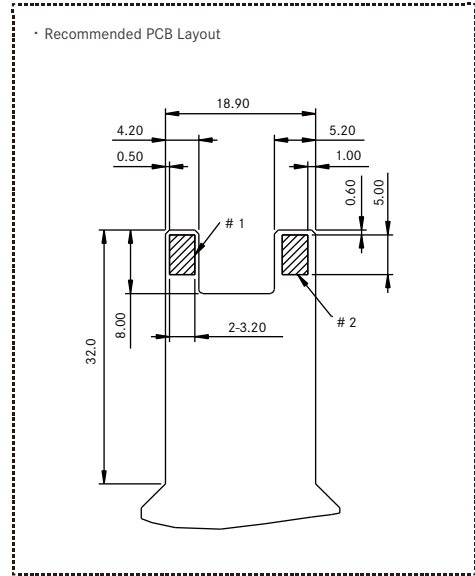
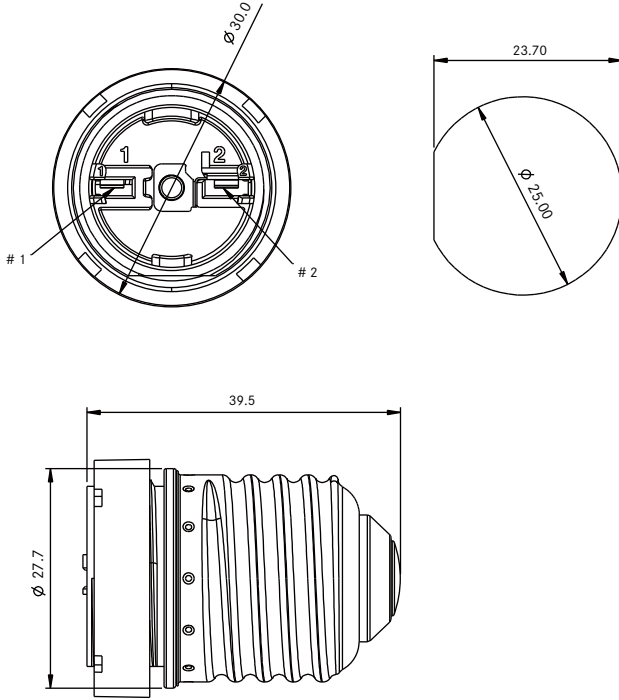

## Find Our Standard Products | SSL 2.3

### SSL 2.3 EZ-B

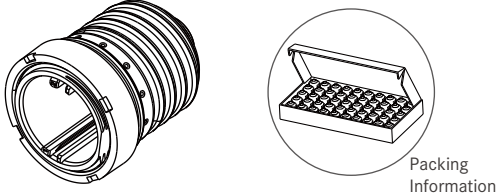
	 <p>Packing Information</p>
Part Number	SSL23-D2S00-000001

【Note】 Design and specification are subject to change without notice.

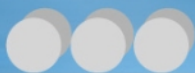

**B.C.E. S.r.l.** - Via Regina Pacis, 54/c - I 41049 Sassuolo (MO), Italy

Tel: (+39) 0536 811616 Fax: (+39) 0536 811500 E-mail: [bce@bce.it](mailto:bce@bce.it) Web: [www.bce.it](http://www.bce.it)

